

GCU-N Screw Gear Kit



Installation : Nonparallel and nonintersecting gears
 Gear Type : Screw Gears
 Gears : SN2.5-10R
 PN2.5-10R equivalent
 Gear Ratio : 1
 Weight : Approx. 1kg

Screw Gears are helical gears used in nonparallel and nonintersecting situations. Applications include devices like conveyers with light loads.

* This is not a gear box for actual use to transmit power. Please use only as representations of gear systems.

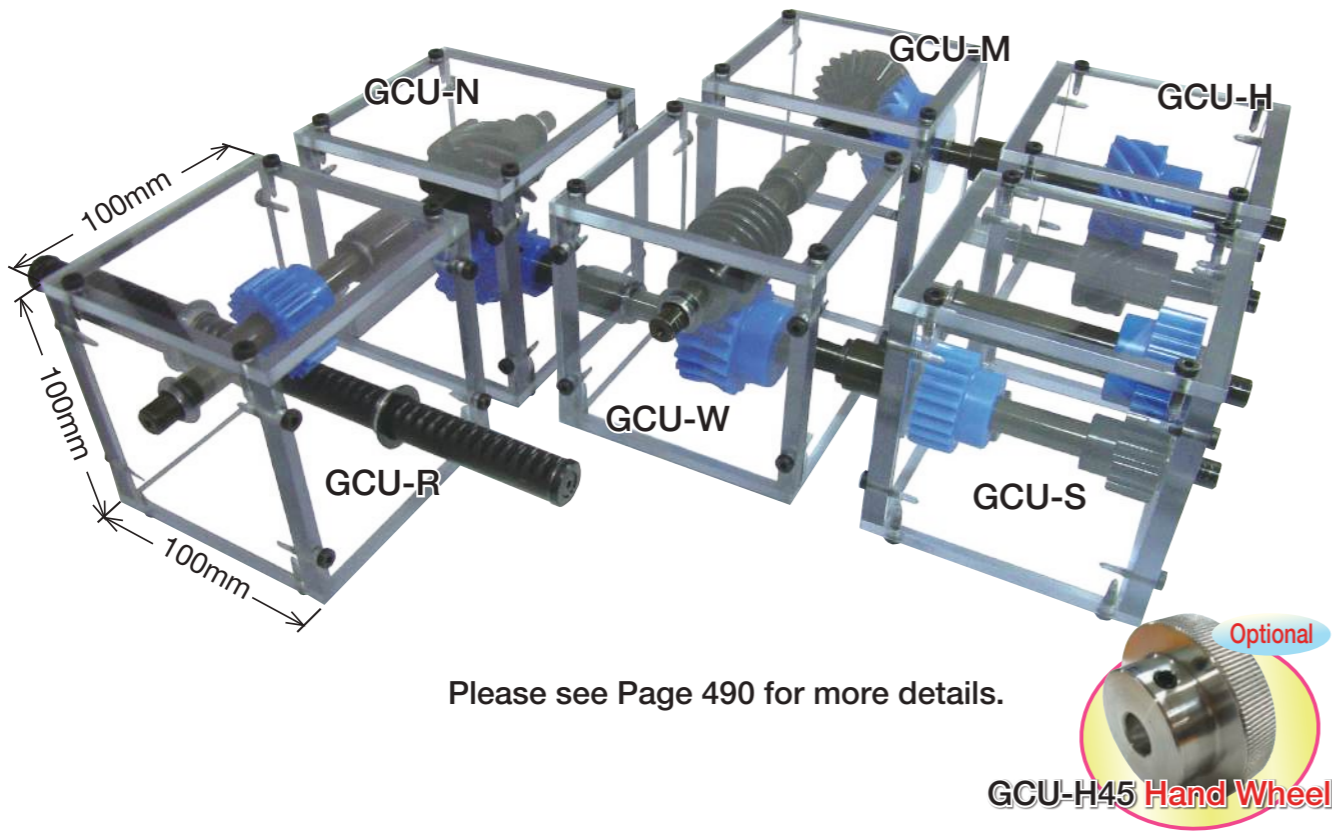

Please see Page 490 for more details.

Optional GCU-H45 Hand Wheel



Worm Gears

KWGD/LKWDLS Duplex Worms <i>NEW</i>	AGDL Duplex Worm Wheels Reduction Ratio 20-40 <i>NEW</i>	KWG Ground Worm Shafts	AG Worm Wheels Reduction Ratio 10-60	AGF Worm Wheels Reduction Ratio 10-60	SWG Ground Worms	AG Worm Wheels Reduction Ratio 10-60 <i>NEW</i>	SW Worms
Material: SCM440 m1.5-6 Page 406	Material: CAC702(A1BC2) m1.5-6 Page 406	Material: SCM440 m0.5-6 Page 416	Material: CAC702(A1BC2) m0.5-1.5 Page 416	Material: CAC702(A1BC2) m2-6 Page 420	Material: S45C m1-6 Page 426	Material: CAC702(A1BC2) m1-6 Page 426	Material: S45C m0.5-10 Page 434
BG Worm Wheels Reduction Ratio 10-60	CG Worm Wheels Reduction Ratio 15-120 <i>NEW</i>	SUW Stainless Steel Worms	PG Worm Wheels Reduction Ratio 10-60				
Material: CAC502(PBC2) m0.5-6 Page 434	Material: FC200 m1-10 Page 436	Material: SUS303 m0.5-3 Page 454	Material: MC901 m0.5-3 Page 454				

M Includes Made to Order

Catalog Number of KHK Stock Gears

The Catalog Number for KHK stock gears is based on the simple formula listed below. Please order KHK gears by specifying the Catalog Numbers.

(Example) Worm Gear Pair

Worms

K W G DL 2 - R1

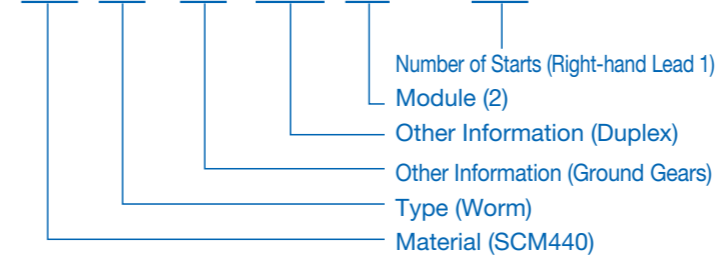

Material
 K SCM440
 S S45C
 SU Stainless Steel

Type
 W Worms
Other Information
 DL Duplex
 G Ground Gears
 S Pinion Shafts

Worm Wheels

A G DL 2 - 20 R1

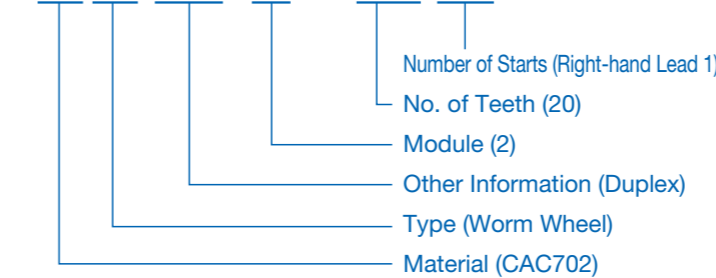

Material
 A CAC702
 B CAC502
 C FC200
 P MC901

Type
 G Worm Wheels
Other Information
 DL Duplex
 F Double Hubs or Ring Gears

Features

KHK stock worm gears are available in modules 0.5 to 6, reduction ratios of 1/10 to 1/120, and a wide range of materials and shapes. Duplex worm gears with adjustable backlash and highly accurate rotation are also available. The following table lists the main features.

Type	Catalog Number	Module	Number of Starts or Reduction Ratio	Material Old JIS in parentheses	Heat treatment	Tooth Surface Finish	Precision Grade KHK W 001 KHK W 002 Note 2	Features
Duplex Worm Gears	Worms KWGDL	2~4	Single Start	SCM440	Thermal refined, gear teeth induction hardened	Ground	1	Duplex worms that have been tempered, hardened and ground that has excellent accuracy, strength and abrasion resistance. Secondary operations can be given except for the teeth. Moving it in axial direction will adjust the backlash.
	Worms KWGDLs	1.5~6	Single Start	SCM440	Thermal refined, gear teeth induction hardened	Ground	1	Duplex worms with shafts that have been tempered, hardened and ground that has excellent accuracy, strength and abrasion resistance. Secondary operations can be given except for the teeth. Moving it in axial direction will adjust the backlash.
	Wheels AGDL	1.5~6	20~60	CAC702 (A & BC2)	—	Cut	1	Duplex worm wheels made of aluminum bronze with excellent accuracy and a good balance between machinability and wear resistance. Used in combination with KWGDL or KWGDLs.
Worm Gears	Worms KWG	0.5~6	Single or Double Start	SCM440	Thermal refined, gear teeth induction hardened	Ground	2	Worms with shafts that have been tempered, hardened and ground that has excellent accuracy, strength and abrasion resistance. Secondary operations can be performed except for the teeth.
	Wheels AGF NOTE 1	2~6	10~60	CAC702 (A & BC2)	—	Cut	2	Worm wheels made of aluminum bronze with a good balance between machinability and wear resistance. Used in combination with KWG.
	Worms SWG	1~6	Single or Double Start	S45C	Gear teeth induction hardened	Ground	2	Worms that have been hardened and ground with a good balance of accuracy, wear resistance and cost. Secondary operations are possible except for the teeth.
	Wheels AG NOTE 1	0.5~6	10~60	CAC702 (A & BC2)	—	Cut	2	Worm wheels made of aluminum bronze with a good balance between machinability and wear resistance. Used in combination with SWG. Note 1
	Worms SW	0.5~10	Single or Double Start	S45C	—	Cut (Rolling)	4	Many lineups are available at a low price and excellent usability.
	Worms SUW	0.5~3	Single or Double Start	SUS303	—	Cut	4	Stainless steel worms with rust resistance.
	Wheels BG	0.5~6	10~60	CAC502 (PBC2)	—	Cut	4	Worm wheels made of phosphorus bronze with excellent wear resistance. Used in combination with SW and SUW.
	Wheels CG	1~10	10~120	FC200	—	Cut	4	Cast iron worm wheels that are inexpensive and suitable for light loads. Used in combination with SW and SUW.
	Wheels PG	0.5~3	10~60	MC901	—	Cut	5	Worm wheels made of MC nylon. Can be used with no lubrication. Used in combination with SW and SUW.

[Note 1] FC200 is the material for the hubs of AGF and AG worm wheels. The AG worm wheels are normally combined with the SWG worms, but are also compatible with the KWG worms with module 1.5 and below.

[Note 2] The precision grade of KHK stock worm gears controls the product quality based on the KHK standards. Please see "Precision of Worm Gears" on Page 400 in the Selection Hints section for details.

High-precision ground gear worms are available.

We use screw grinding machines manufactured by DRAKE, USA, to manufacture high-precision ground worms of module 0.5 to 8.



CNC Screw Grinding Machine (TE-LM200)

Worm ground gear machining range	
Maximum gear accuracy	KHK Grade 1
Maximum module	m8
Maximum nominal lead angle	±35°
Maximum outer diameter	φ 200mm
Maximum length	330mm

Application Examples

Worm gears are used in a wide range of fields, such as positioning mechanisms and reversing mechanisms.

Wiper Drive Device



Worm gear used for the oscillating mechanism of wipers

Image: Provided by PK Design

Yaesu Steam Kettle



SW worm and CG worm wheel used for rotating large pans

Masdac Food Filling Device



KWGDL Duplex Worm Wheels and AGDL Worm Wheels used for indexing and driving, for accurate filling of a fixed amount of ingredients

Worm Jack

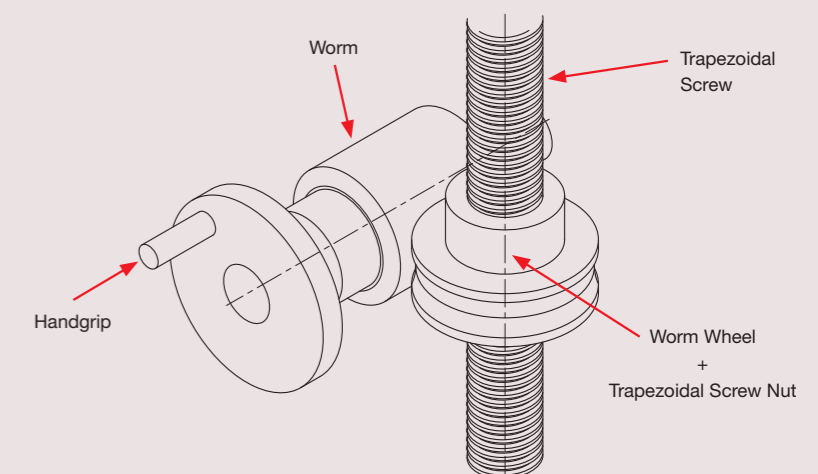

Gonio Stage Design Example

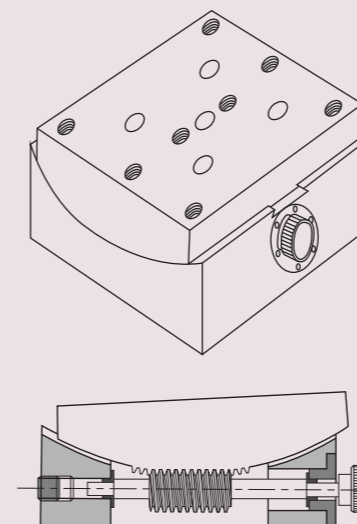

Worm gear used for rotating tables (design example)

Selection Hints

Please select the most suitable products by carefully considering the characteristics of items and contents of the product tables. It is also important to read all applicable "CAUTION" notes shown below before the final selection.

1. Caution in Selecting the Mating Gears

Worm gears are available in right-hand helix and left-hand helix. Worms and worm wheels of the same helix direction are combined. However, combination may not be possible due to the difference in the number of starts of the worm and the difference in pitch being normal and transverse (axial direction). Below is the Mating Helical Gear Selection Chart for KHK worm gears.

Mating Worm Wheel Selection Chart

Worms		KWGD/L KWGDLS	KWG		SWG		SW				SUW	
Mating Wheel Note 1	Hand Number of Starts	R1	R1	R2	R1	R2	R1	R2	L1	L2	R1	R2
AGDL	R1	○										
AG0.5~1.5	R1		○									
AGF	R2			○								
AG	R1				○							
BG	R1						○					○
	R2							○				
	L1								○			
CG	R1							○				○
	R2								○			
	L1									○		
PG	R1										○	○
	R2										○	

[Note 1] The mating wheel must have the same module as the worm.

Helix direction of worm gears

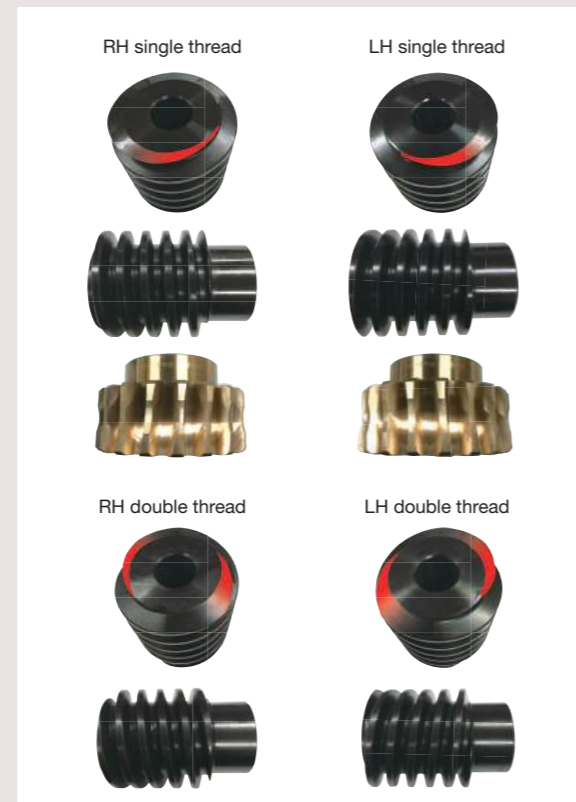

2. Caution in Selecting Gears Based on Gear Strength

The gear strength values shown in the product pages were computed by assuming the application environment in the table below. Therefore, they should be used as reference only. We recommend that each user computes their own values by applying the actual usage conditions.

Calculation of Surface Durability

Calculation of Bending Strength of Gears

Item	Catalog Number	KWGD/L/KWGDLS/AGDL KWG/AGF, SWG/AG	SW/BG	SW/CG	SUW/PG
Formula NOTE 1	Formula of cylindrical worm gear strength (JGMA405-01)				The Lewis formula
Lubricating Oil	Lubricating oil with appropriate viscosity that contains extreme pressure additive for gears				Allowable bending stress (kgf/mm ²)
Lubrication Method	Oil Bath Lubrication (Oil Bath)				1.15 (40°C with No Lubrication)
Startup Status	The starting torque is 200% or less of the rated torque, and the number of starts per hour is under 2.				
Expected Service Life	26,000 hours				
Impact from motor	Uniform load				
Impact from load	Uniform load				
Allowable Stress Coefficient Scilm	0.67	0.70	0.42		

[NOTE 1] The gear strength formula is based on JGMA (Japanese Gear Manufacturers Association) specifications, "MC Nylon Technical Data" by Mitsubishi Chemical Advanced Materials. The units for the rotational speed (rpm) and the stress (kgf/mm²) are adjusted to the units needed in the formula.

When selecting KHK standard gears, glance over the Product Precautions on page 402 and Cautions on Performing Secondary Operations on each page.

- Products not listed in this catalog or materials, modules, number of teeth and the like not listed in the dimensional tables can be manufactured as custom items. Please see Page 26 for more details about custom-made orders.
- The color and shape of the product images listed on the dimension table page of each product may differ from the actual product. Be sure to confirm the shape in the dimension table before selection.
- The details (specifications, dimensions, etc.) listed in the catalog may be changed without prior notice. Changes are announced on the KHK website.

Website URL : <https://khkgears.net/new/>
Overseas Sales Department: Phone : +81-48-254-1744 Fax: +81-48-254-1765 E-mail: info@khkgears.net

The most important factor in selecting gears is the gear strength.

Step 1

Use the calculation of load torque applied to the gear and the sliding speed to determine the worm gear suitable for the purpose.

Maximum allowable sliding speed due to friction

The maximum allowable sliding speed of each worm gear is shown in the table below. Sliding speed should be calculated when making a selection.

Sliding speed v_s (m/s)

$$v_s = \frac{dn}{19100 \cos \gamma}$$

d : Worm pitch dia.
 n : Worm rotational speed
 γ : Worm nominal lead angle

Catalog Number	Maximum allowable sliding speed (m/s)
AGDL	* 15
AGF	* 15
AG	* 15
BG	* 10
CG	* 2.5
PG	1 (No Lubrication)

* From JGMA405-01

Surface durability

Calculated values of the strength at which the worm wheel teeth do not wear due to surface fatigue damage. If the tooth surface is not sufficiently lubricated, the surface may be damaged even if the load is less than the tooth surface durability.

Step 2

Select provisionally from the allowable torque table in this catalog based on the load torque.

For provisional selection from this catalog

Catalog Number	Rotational speed (rpm)	Transverse module (mm)	No. of starts	Lead angle (degrees)	Dinckler factor	Allowable Torque (N·m)						Backlash (mm)	
						2	30	100	300	600	1200		1800
AG0.5-20R1	30	m0.5	20	1°31'11"	R	9.5	0.52	0.44	0.36	0.30	0.26	0.24	0.21
AG0.5-20R2	10		2	6°20'		9.5	0.51	0.42	0.33	0.27	0.24	0.22	0.19
AG0.5-30R1	30		30	1°31'11"		12	1.09	0.94	0.77	0.65	0.58	0.53	0.48
AG0.5-40R1	40		40	1°31'11"		14.5	1.86	1.60	1.34	1.15	1.02	0.94	0.84
AG0.5-50R1	50		50	1°31'11"		17	2.82	2.42	2.05	1.77	1.58	1.46	1.30
AG0.5-60R1	60		60	1°31'11"		19.5	3.94	3.41	2.89	2.50	2.26	2.08	1.87
AG0.8-20R1	20	m0.8	20	1°34'49"	R	4	1.76	1.50	1.21	1.00	0.88	0.82	0.71
AG0.8-20R2	10		2	7°36'		4	1.76	1.44	1.11	0.91	0.80	0.74	0.63
AG0.8-30R1	30		30	1°34'49"		8	3.77	3.21	2.62	2.20	1.96	1.81	1.61
AG0.8-30R2	15		2	7°36'		8	3.75	3.14	2.46	2.02	1.80	1.65	1.45
AG0.8-40R1	40		40	1°34'49"		2	6.45	5.49	4.55	3.87	3.46	3.19	2.83
AG0.8-50R1	50		50	1°34'49"		25	9.75	8.31	6.94	5.94	5.34	4.96	4.38
AG0.8-60R1	60	60	1°34'49"		30	13.6	11.7	9.77	8.39	7.63	7.05	6.27	

Step 3

Calculate the strength under the actual usage conditions.

Calculate the strength formally using the various gear strength formulas. We recommend using the simple strength calculation available on our website.

Use the strength calculation function on our website.

3. Cautions on Selecting Racks By Precision

The precision standards of KHK stock worm gears are established by us. Check the precision table below.

① Worm Precision (KHK W 001)

For the pitch error and lead error of the worm, the allowable values of 1 to 4 grades are set for each module with reference to the JIS standards. The lead error is the allowable value of the tooth trace error in one lead.

■ Worm Precision KHK W 001 (Unit: μ m)

Grade	Error	Module				
		Over m0.4 to 1	Over m1 to 1.6	Over m1.6 to 2.5	Over m2.5 to 4	Over m4 to 6
1	Pitch Error	8	12	16	20	25
	Lead Error	7	9	11	13	16
2	Pitch Error	12	16	20	24	29
	Lead Error	15	18	21	25	28
3	Pitch Error	16	23	30	37	50
	Lead Error	20	23	27	33	37
4	Pitch Error	20	30	40	50	70
	Lead Error	30	32	38	46	52

② Worm Wheel Accuracy (KHK W 002)

Our precision grades for pitch errors are established by referring to old JIS Standards. The precision grades are set from 1 to 5, in accordance with the tolerance of a single pitch error (S.P.E.), adjacent tooth-to-tooth error (T.T.E.), and the total composite error (T.C.E.) for each module and pitch diameter.

■ Worm Wheel Accuracy KHK W 002

Unit: μ m

Grade	Error	Pitch dia. (mm)																								
		Over m0.4 to 1					Over m1 to 1.6					Over m1.6 to 2.5					Over m2.5 to 4					Over m4 to 6				
		6 to 12	12 to 25	25 to 50	51 to 100	100 to 200	12 to 25	25 to 50	51 to 100	100 to 200	200 to 400	12 to 25	25 to 50	51 to 100	100 to 200	200 to 400	25 to 50	51 to 100	100 to 200	200 to 400	400 to 800	25 to 50	51 to 100	100 to 200	200 to 400	400 to 800
1	Single Pitch Error	5	6	7	7	9	6	7	8	9	10	7	7	8	9	11	8	9	10	11	13	9	10	11	13	14
	Total Pitch Error	21	24	26	30	34	25	28	31	35	41	27	30	33	37	43	33	36	40	46	53	37	40	45	50	57
2	Single Pitch Error	8	8	9	10	12	9	10	11	12	14	9	10	12	13	15	11	13	14	16	18	13	14	16	18	20
	Total Pitch Error	30	33	37	42	48	35	39	44	50	57	38	42	46	52	60	46	51	57	64	74	52	57	63	71	80
3	Single Pitch Error	11	12	13	15	17	12	14	16	18	20	13	15	16	19	21	16	18	20	23	26	19	20	22	25	29
	Total Pitch Error	43	47	53	60	68	50	55	62	71	81	53	59	66	74	85	65	72	81	91	105	74	81	90	100	115
4	Single Pitch Error	15	17	19	21	24	18	19	22	25	29	19	21	23	26	30	23	25	28	32	37	26	28	32	35	40
	Total Pitch Error	60	66	74	83	95	70	77	87	99	115	75	83	92	105	120	91	100	115	130	145	105	115	125	140	160
5	Single Pitch Error	21	24	26	30	34	25	28	31	35	41	27	30	33	37	43	33	36	40	46	53	37	40	45	50	57
	Total Pitch Error	86	94	105	120	135	100	110	125	140	165	105	120	130	150	170	130	145	160	185	210	150	160	180	200	230

③ Total Length Tolerance for Worm Gears

■ Total Length Tolerance for Worms

Series	Total Length (mm)	Tolerance
KWGDL	Uniform	0 -0.10
	100 or less	0 -0.15
SWG SW SUW	Over 100 200 or less	0 -0.20
	Uniform	Normal Tolerance

■ Total Length Tolerance for Worm Wheels

Total Length (mm)	Tolerance
30 or less	0 -0.10
31 to 100	0 -0.15
Over 100	0 -0.20

[NOTE] PG Plastic Wheels are excluded.

4. Cautions in Selecting Worm Gears Based on Efficiency

The transmission efficiency of worm gears varies slightly depending on the assembled state, lubricating oil and the like, but the transmission efficiency (excludes bearing loss and loss of lubricating oil due to stirring) of worm wheels when driven from the worm is approximately 30% to 90%. The transmission efficiency table of the KHK stock worm gears is shown below (reference values).

① Efficiency of Various Worms

■ KWGDL/KWGDLS/AGDL Worm Gear Efficiency (%)

(rpm = Worm Rotational Speed)

Worm Rotational Speed Catalog Number	100	300	600	900	1200	1800
KWGDLS1.5-R1	35	42	47	51	53	57
KWGDLS2-R1	38	45	51	55	56	61
KWGDLS2.5-R1	40	48	54	57	60	63
KWGDLS3-R1	41	49	55	58	62	65
KWGDLS3.5-R1	42	50	56	61	62	65
KWGDLS4-R1	42	51	56	61	63	67

■ KWG/AG/AGF Worm Gear Efficiency (%)

(rpm = Worm Rotational Speed)

Worm Rotational Speed Catalog Number	100	300	600	900	1200	1800
KWG0.5-R1	30	34	38	41	43	46
KWG0.8-R1	35	40	44	47	49	53
KWG1-R1	34	40	45	48	51	54
KWG1.5-R1	35	42	47	51	53	57
KWG2-R1	45	51	56	60	62	65
KWG2.5-R1	44	51	57	61	62	67
KWG3-R1	44	52	58	61	64	67
KWG4-R1	50	58	64	66	70	72
KWG5-R1	51	60	66	69	71	73
KWG6-R1	53	61	66	70	72	75
KWG0.5-R2	46	50	54	58	60	63
KWG0.8-R2	51	56	61	64	66	69
KWG1-R2	51	56	62	64	67	70
KWG1.5-R2	52	59	64	67	69	73
KWG2-R2	61	67	71	74	76	78
KWG2.5-R2	60	67	72	75	76	80
KWG3-R2	61	68	73	75	78	80
KWG4-R2	66	73	77	79	82	84

■ SWG/AG Worm Gear Efficiency (%)

(rpm = Worm Rotational Speed)

Worm Rotational Speed Catalog Number	100	300	600	900	1200	1800
SWG1-R1	34	40	45	48	51	54
SWG1.5-R1	35	42	47	51	53	57
SWG2-R1	38	45	51	55	56	61
SWG2.5-R1	40	48	54	57	60	63
SWG3-R1	41	49	55	58	62	65
SWG4-R1	42	51	56	61	63	67
SWG5-R1	46	54	60	64	66	70
SWG6-R1	48	57	64	66	68	73
SWG1-R2	51	56	62	64	67	70
SWG1.5-R2	52	59	64	67	69	73
SWG2-R2	55	62	67	70	72	75
SWG2.5-R2	57	64	69	72	75	77
SWG3-R2	58	66	71	73	76	78
SWG4-R2	59	67	72	75	77	80
SWG5-R2	62	70	75	78	79	82
SWG6-R2	65	72	77	80	81	84

■ SW, SUW/CG, BG, PG Worm Gear Efficiency

The values shown in the table below are estimates and may vary slightly according to conditions such as assembled state, load, lubrication and rotation speed.

Catalog Number	Number of Starts	Efficiency (%)
SW/SUW	1 Start	30~50%
	2 Starts	50~60%

② Self-locking of worm gears

The state of the worm not being able to be rotated from the worm wheel is called self-locking. Self-locking happens due to the worm gear's material, lead angle, machining accuracy, bearing type, lubricating oil, etc.

There are various factors, so self-lock is not always determined only by the lead angle, but usually a single-start worm self-locks at a lead angle of 4° or less. If complete reverse prevention is required, use another braking mechanism or the like in combination.

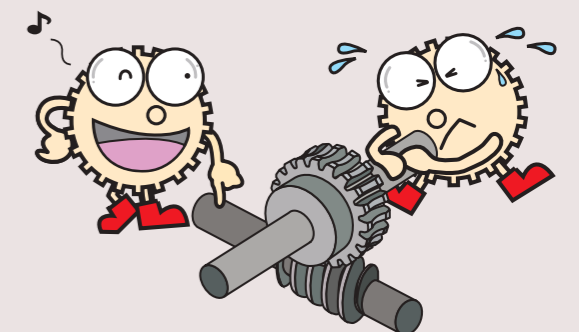

Product Precautions



Worm Common Notes

[Caution on Product Characteristics]

- (1) These worm gears produce axial thrust forces. Please see page 404 for more details.
- (2) Keyways are made according to JIS B1301 standards, Js9 tolerance. Also note that keyway tooth position alignment is not performed.
- (3) For products having a tapped hole, a set screw is included.
- (4) For bores of ϕ 4 or below, the bore tolerance is H8. As well, the tolerance is H8 for ϕ 5 or ϕ 6 bores with hole length (total length) 3x the bore or more.
- (5) For hole lengths 3.5x the bore or more, the hole center is out of H7 tolerance.

[J Series]

- (1) Black oxide is not re-applied to parts undergoing secondary operations.

Worm Wheel Common Notes

[Caution on Product Characteristics]

- (1) The allowable torque shown in the table are calculated values according to the assumed usage conditions. Please see page 398 for more details.
- (2) Variations in temperature or humidity can cause dimensional changes in plastic gears, including tooth diameter, bore, and backlash. The accuracy and tolerances shown in the catalog are values obtained when machining is performed.
- (3) For bores of ϕ 4 or below, the bore tolerance is H8. As well, the tolerance is H8 for ϕ 5 or ϕ 6 bores with hole length (total length) 3x the bore or more.
- (4) These worm gears produce axial thrust forces. Please see page 404 for more details.
- (5) Some products have a slight gap in the casted section, but this does not affect the holding strength.
- (6) Keyways are made according to JIS B1301 standards, Js9 tolerance. Also note that keyway tooth position alignment is not performed.
- (7) For products having a tapped hole, a set screw is included.
- (8) FC200's tensile strength (200N/mm²) is derived from test specimens and does not represent that of the boss.

[Caution on Secondary Operations]

- (1) Because it affects the cast portion, there is no additional modification other than to the boss part.
- (2) As the worm wheel is casted, bubbles may form inside the material.
If the air bubbles found in secondary operations are problematic, contact the supplier.

[J Series]

- (1) Certain products which would otherwise have a very long tapped hole are counterbored. For details, please see the KHK website.
- (2) For bores over ϕ 50, the bore tolerance is H8.

Tapped Holes in Semi-Custom Standard Products

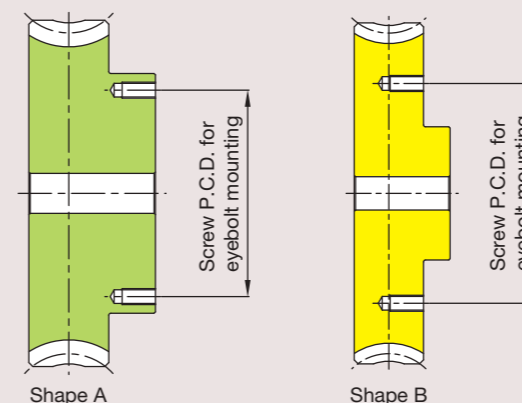

Catalog Number	Shape	Screw P.C.D. for eyebolt mounting
AGDL5-50R1S	A	205
AGDL5-60R1S	A	255
AGDL6-40R1S	A	195
AGDL6-50R1S	A	255
AGDL6-60R1S	A	315

Catalog Number	Shape	Screw P.C.D. for eyebolt mounting
CG5-50L1S	B	155
CG5-60L1S	B	165
CG6-40L1S	B	165
CG6-50L1S	B	165
CG6-60L1S	B	185
CG8-30R1S	A	155
CG8-40R1S	A	195
CG8-50R1S	A	215
CG10-20R1S	A	140
CG10-30R1S	A	215
CG10-40R1S	A	255

Application Hints

In order to use KHK stock worm gears safely, carefully read the Application Hints before proceeding. If there are questions or you require clarifications, please contact our technical department or your nearest distributor. E-mail: info@khkgears.net Please read "Cautions on Performing Secondary Operations" below when performing modifications and/or secondary operations for safety concerns.

1. Cautions on Handling

- ① KHK products are packaged one by one to prevent scratches and dents, but if you find issues such as rust, scratches, or dents when the product is removed from the box after purchase, please contact the supplier.
- ② Depending on the handling method, the product may become deformed or damaged. Resin gears and ring gears deform particularly easily, so please handle with care.

2. Caution on Performing Secondary Operations

- ① Gears are machined based on the ground section of the hole or shaft. If machining, it is important to pay special attention to locating the center in order to avoid runout. (Fig.1) If it is too difficult to do for small bores, the alternative is to use one spot on the bore and the runout of the hub end surface.

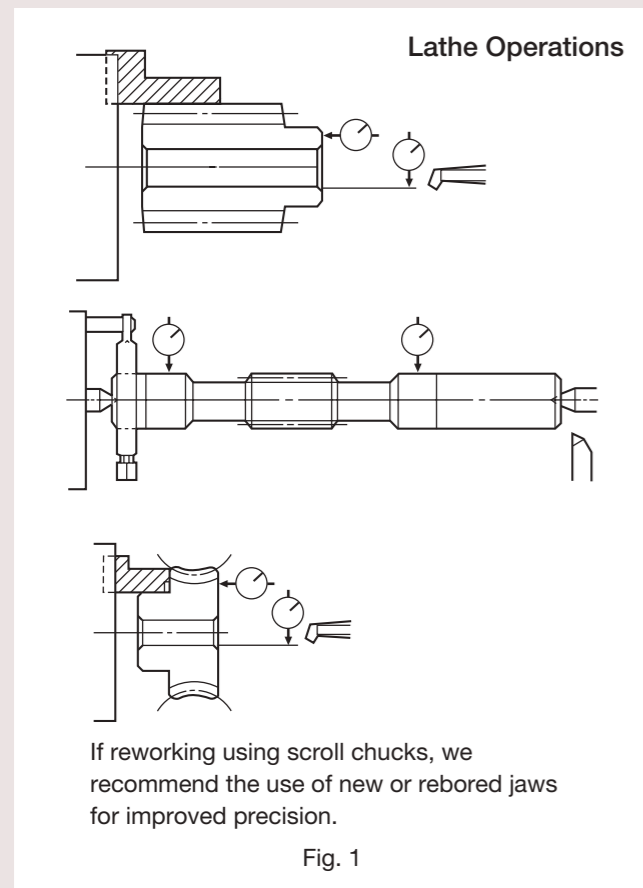

- ② If enlarging the bore diameter, the wall strength of the hub must be higher than that of the gear teeth. The maximum bore size should be 60% to 70% of the hub diameter (or tooth root diameter), and 50% to 60% for keyway applied modifications. Also, because the cast FC200 hub is weaker and more brittle than other steels, we recommend using a maximum bore diameter about 10% smaller.
- ③ As the worm wheel is casted, bubbles may form inside the material. If the air bubbles found in secondary operations are problematic, contact the supplier.

3. Points of Caution during Assembly

- ① The recommended center distance tolerance of KHK stock worm gears is H7 for ground gears and H8 for cut gears. The amount of backlash is given in the product table for each gear.
- ② The mounting reference surface of the worm wheel is as shown in the figure below. Assemble the worm wheel so that the center of the worm shaft is at the center of its tooth width.

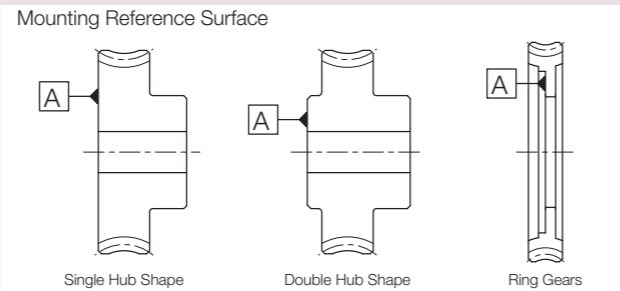

- ③ As the tooth trace of worm gears is spiraled, axial thrust force is generated. Also, the directions of thrust change with the hand of helix and the direction of rotation. This is illustrated below. The bearings must be selected properly to be able to handle these thrust forces. For details, use gear calculation software GCSW.

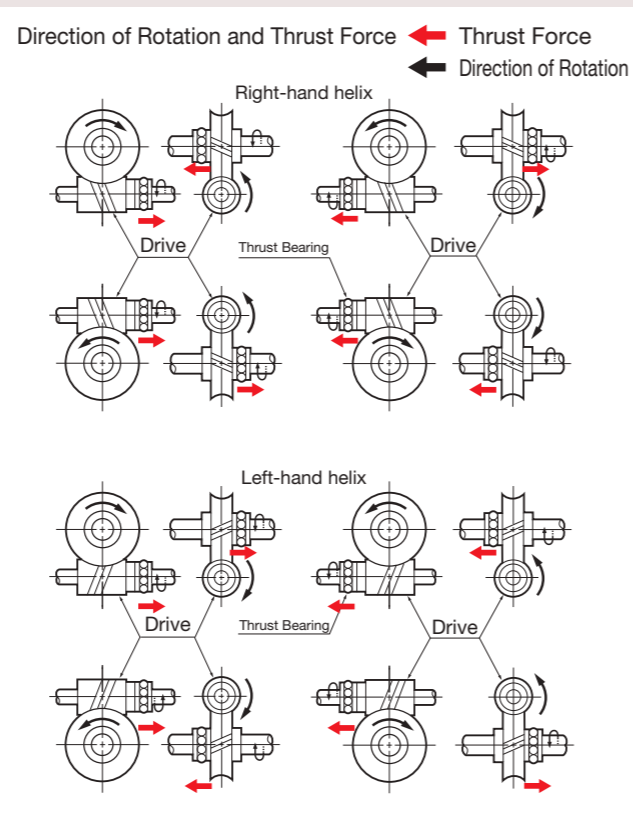

- ④ The worm may move due to a large thrust force that acts on the worm if it is not sufficiently attached to the shaft. Use a stepped shaft to secure the worm and shaft, and be careful not to loosen the bearing.

4. Confirming the installation

The wear of a worm gear is greatly affected by the quality of assembly. When assembling, confirm the following items for tooth contact and the like before use.

- The shaft angle tolerance between the worm shaft and worm wheel shaft is $90^\circ \pm 1'$.

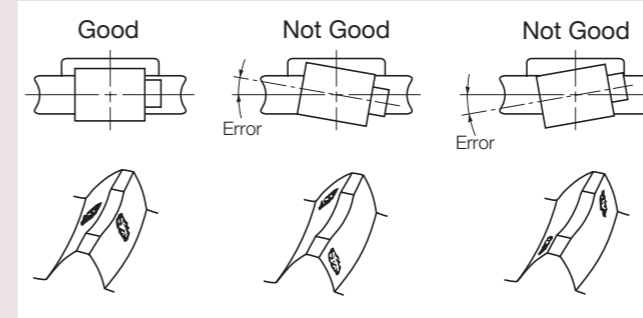

- The center distance tolerance recommended by the worm gear assembly distance is Ground Worm Gears...H7 Cut Worm Gears...H8.

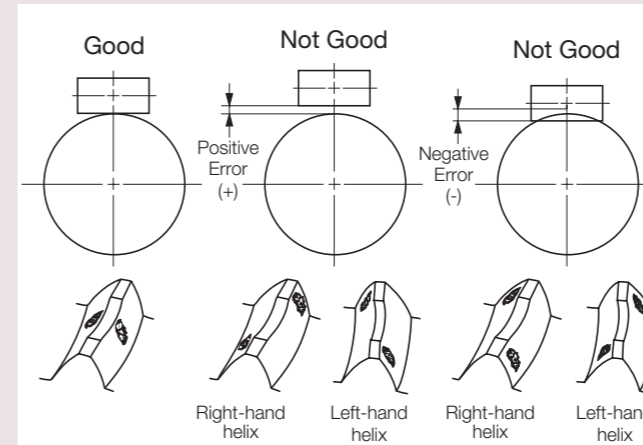

- The tolerance between the center of the worm shaft and center of the worm wheel tooth width is ± 0.2 mm.

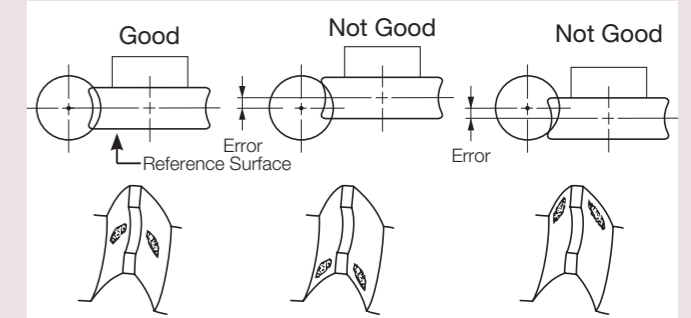

- The tolerance between the center of the worm wheel shaft and center of the worm tooth width is ± 2 mm.

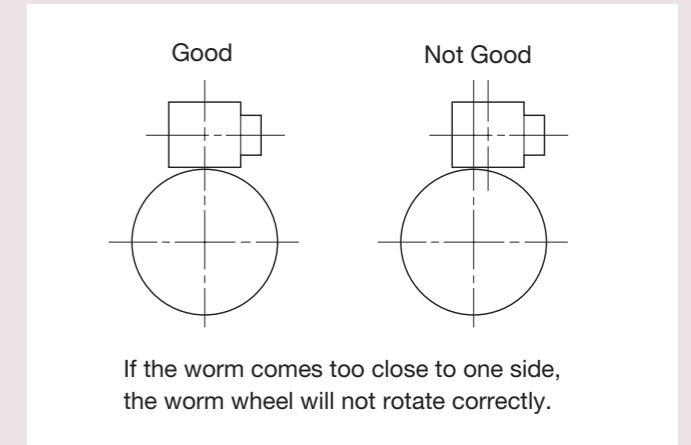

5. Cautions on Starting

- ① Check the following items before starting.
 - Are the gears installed securely?
 - Is there uneven tooth contact?
 - Is there adequate backlash?
 - (Be sure to avoid zero-backlash.)
 - Has proper lubrication been supplied?
- ② If gears are exposed, be sure to attach a safety cover to ensure safety. Also, be careful not to touch rotating gears.

- ③ If there is any abnormality such as noise or vibration during startup, stop the operation immediately and check the assembly condition such as tooth contact, eccentricity and looseness.

KHK considers safety a priority in the use of our products.

When handling, adding secondary operations, assembling, and operating KHK products, please be aware of the following issues in order to prevent accidents.

Warning: Precautions for preventing physical and property damage

1. When using KHK products, follow relevant safety regulations (Occupational Safety and Health Regulations, etc.).
2. Pay attention to the following items when installing, removing, or performing maintenance and inspection of the product.
 - ① Turn off the power switch.
 - ② Do not reach or crawl under the product.
 - ③ Wear appropriate clothing and protective equipment for the work.

Caution: Cautions in Preventing Accidents

1. Before using a KHK product, read the precautions in the catalog carefully in order to use it correctly.
2. Avoid use in environments that may adversely affect the product.
3. Our products are manufactured under a superior quality control system based on the ISO9001 quality management system; if you notice any malfunctions upon purchasing a product, please contact the supplier.

Description of duplex worm gears

The usual method of adjusting the backlash of a worm gear assembly is to modify the center distance. Once assembled, such adjustment requires a major rework of the gearbox housing. The use of duplex worm gears allows the backlash adjustment to be made by axially shifting the worm. This simplifies greatly the assembly and maintenance operations. Because of the unique characteristics of the product, please take time to study its construction and proper use.

Backlash adjustment mechanism and method of adjustment

The dual-lead worm is formed to give a difference between the right tooth surface and left tooth surface so that it provides a unique tooth profile in which the tooth thickness varies continuously, corresponding with the lead difference. (Fig.1)

The worm gear is also formed in its right and left tooth surface. When such a worm and worm gear are set up at a constant assembly distance and the worm is moved in the axial direction, the tooth thickness of the worm in mesh with the worm gear changes making backlash adjustment possible.

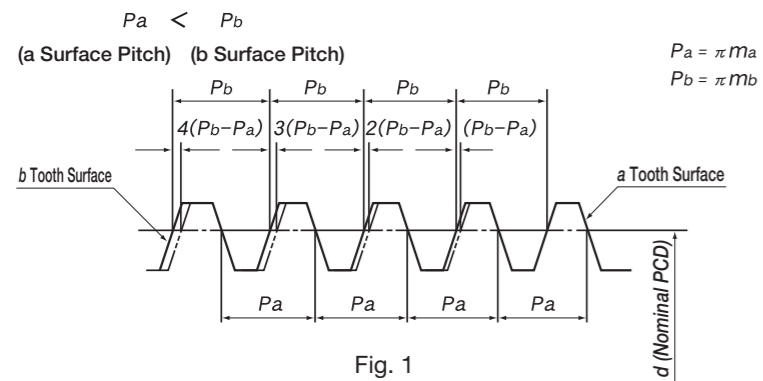

[CAUTION] The amount of change in backlash (Δj mm) in relation to the axial movement of the duplex worm shaft (V mm) can be calculated from the formula below.

$$\Delta j = 2V \frac{m_b - m_a}{m_a + m_b}$$

Where
 m_a = Nominal Axial Module - (0.01 × Nominal Axial Module)
 m_b = Nominal Axial Module + (0.01 × Nominal Axial Module)



An arrow marking on the outer circumference of the hub of the KHK duplex worm indicates the direction of assembly as well as acts as a direction for the backlash adjustment. When the worm is held with arrow mark pointing right, the tooth thickness is thinner on the right and thicker on the left. Therefore, moving the worm to the right causes the thicker teeth to come into actual engagement with the worm gear, thereby reducing the backlash. (Fig.2)

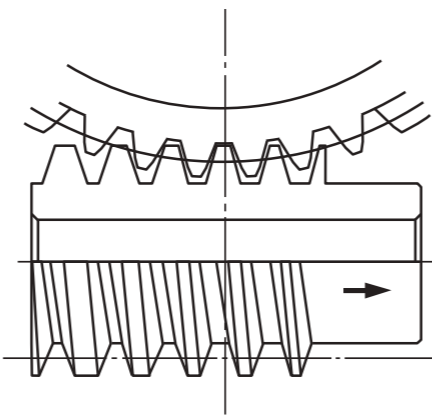

Fig. 2

[CAUTION] The KHK duplex worm is designed so that, for all modules, the backlash reduces by 0.02 mm when the worm is shifted 1 mm.

Application Examples * The illustration is a design example, not a design for machinery or a device in actual use.

Adjustment by using Screws
 Adjustment by using Shims

Points of caution during assembly

KHK duplex worm gears differ in module between the right and left tooth surface and, therefore, you must orient the worm and worm wheel properly. Please carefully verify the following two aspects before proceeding with assembly.

1. Verifying the orientation of assembly
 An arrow indicating the orientation of assembly is stamped on both the duplex worm and worm wheel. When assembling the worm and worm wheel, check the worm wheel of the arrow mark on the front such that the direction of arrow mark on the worm coincides with that on the worm wheel. Incorrect assembly results in difficulty of assembly and improper gear engagement. (Fig.3)

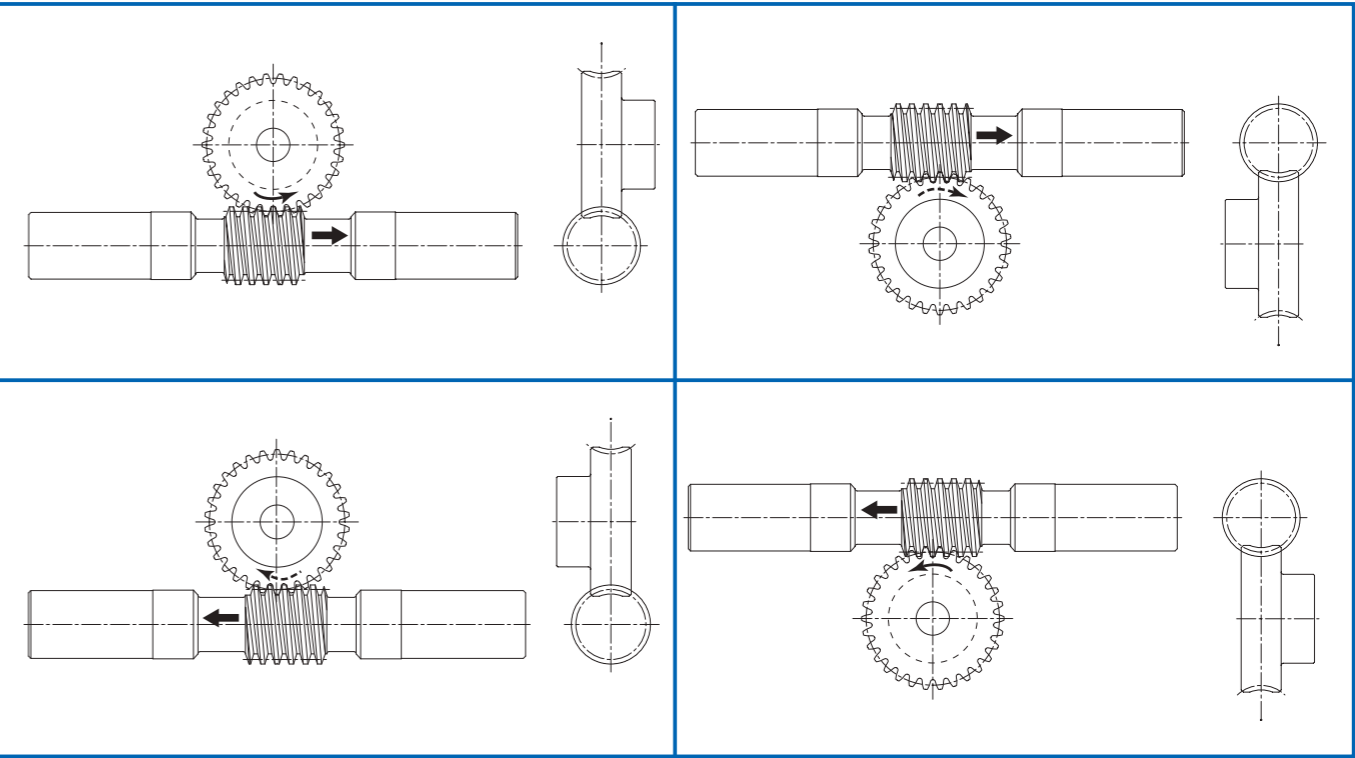

Arrow mark indicates the correct orientation of two gears when assembled. As shown, the two arrows must point in the same direction. Fig. 3

2. Verifying the reference position
 A V-groove (60°, 0.3 mm deep line) on tip peripheral of the duplex worm tooth marks the reference tooth. The gear set is designated to have a backlash of nearly zero (tolerance: ±0.045) when the reference tooth is positioned in alignment with the center of rotation of the worm wheel with the center distance set at the value "a". (Fig.4)

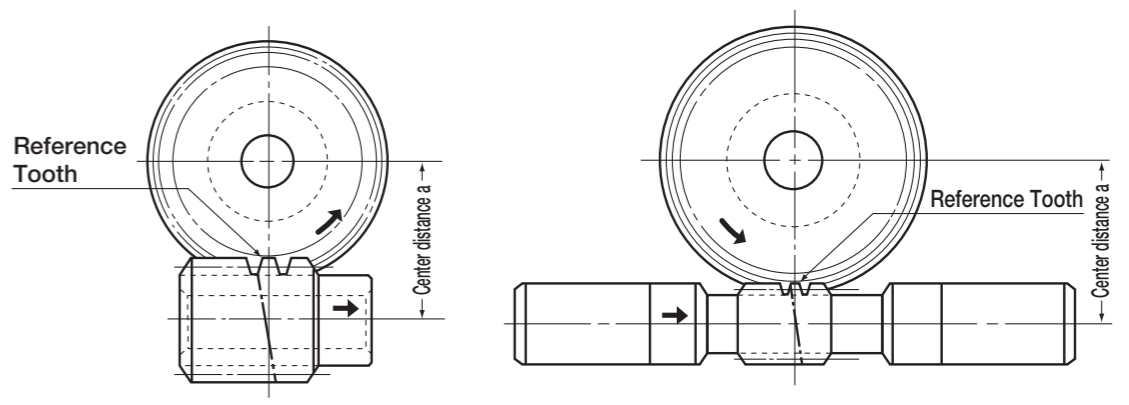
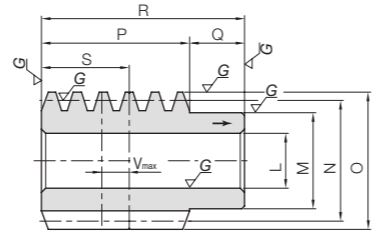

Fig. 4



Specifications	
Precision grade	KHK W 001 grade 1
Reference section of gear	Axial direction
Gear teeth	Standard full depth
Normal pressure angle	17°30'
Material	SCM440
Heat treatment	Thermal refined, gear teeth induction hardened*
Tooth hardness	50 to 60HRC
Surface treatment	Black oxide coated except for ground part

* Due to the gear teeth being induction hardened, no secondary operations can be performed on tooth areas including the bottom land (approx. 2 to 3 mm).



W4

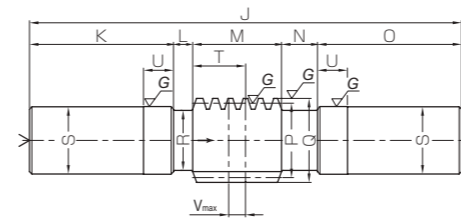

W6

Catalog Number	Nominal axial module	Number of Starts	Nominal lead angle	Direction of helix	Shape	Bore		Pitch dia.	Outside dia.	Face width	Hub width	Total length
						L _{H7}	M					
KWGDL2-R1	m2	1	3°41'	R	W4	14	25	31	35	36	14	50

Position of reference tooth	Max. allowable shift	Weight (kg)	Catalog Number
S	V _{max}	0.21	KWGDL2-R1
22	8		

Catalog Number	Nominal axial module	Number of Starts	Nominal lead angle	Direction of helix	Shape	Total Length	Shaft length (L)	Neck length (left)	Face width	Neck length (right)	Shaft length (R)	Pitch dia.
						J	K	L	M	N	O	P
KWGDL1.5-R1	m1.5	1	3°26'	R	W6	190	66	12	28	18	66	25
KWGDL2-R1	m2	1	3°41'	R	W6	220	75	13	36	21	75	31

Outside dia.	Neck dia.	Shaft dia.	Position of reference tooth	Grinding length of shaft	Max. allowable shift	Weight (kg)	Catalog Number
Q	R	S	T	U	V _{max}	0.74	KWGDL1.5-R1
28	21	26.2	17	20	6		
35	24	30.2	22	20	8	1.17	KWGDL2-R1

[Caution on Product Characteristics] ① When adjusting the worm to reduce the backlash, V_{max} is the maximum amount of distance that you may shift it without causing problems with the gear mesh. V_{max} is not the recommended value to use for adjustment during assembly.

AGDL
Duplex Worm Wheels



Specifications	
Precision grade	KHK W 002 grade 1
Reference section of gear	Rotating plane
Gear teeth	Standard full depth
Normal pressure angle	17°30'
Material	CAC702 (old JIS A & BC2)
Heat Treatment	—
Tooth hardness	—

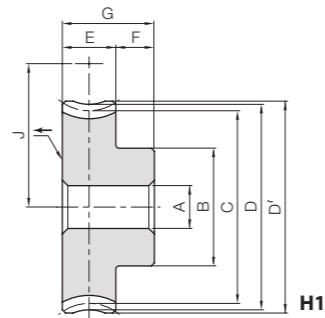

H1



Catalog Number	Reduction ratio	Nominal transverse module	No. of teeth	Lead angle	Direction of helix	Shape	Bore		Hub dia.	Pitch dia.	Throat dia.	Outside dia.	Face width	Hub width
							A _{H7}	B						
AGDL1.5-20R1	20	m1.5	20	3°26'	R	H1	8	22	30	33	34.5	14	10	
AGDL1.5-30R1	30		10				30							
AGDL1.5-40R1	40		12				35							
AGDL1.5-50R1	50		12				45							
AGDL1.5-60R1	60		12				50							
AGDL2-20R1	20	m2	20	3°41'	R	H1	12	33	40	44	46	18	15	
AGDL2-30R1	30		15				40							
AGDL2-40R1	40		15				45							
AGDL2-50R1	50		15				50							
AGDL2-60R1	60		15				60							

[Caution on Product Characteristics] ① For duplex worm gears, mount the worm and wheel with the arrows pointing in the same direction. The arrows on the wheels indicate the direction of assembly and do not determine the direction of rotation. See assembly instructions on page 404.

Total length	Web thickness	Web O.D.	Mounting distance	Allowable torque (N·m) ^{NOTE 1}							Backlash (mm)	Weight (kg)	Catalog Number	
				30 rpm	100 rpm	300 rpm	600 rpm	900 rpm	1200 rpm	1800 rpm				
24	—	—	J	27.5	9.84	8.18	6.40	5.30	4.68	4.25	3.68	0±0.045	0.10	AGDL1.5-20R1
				35	20.8	17.5	13.9	11.7	10.4	9.40	8.28			
				42.5	35.6	30.0	24.2	20.6	18.3	16.6	14.6			
				50	53.8	45.4	36.9	31.6	28.3	25.8	22.6			
				57.5	75.3	63.8	51.9	44.7	40.4	36.7	32.4			
33	—	—	J	35.5	21.0	17.5	13.6	11.2	9.84	8.94	7.75	0±0.045	0.26	AGDL2-20R1
				45.5	44.3	37.3	29.6	24.8	21.9	19.8	17.4			
				55.5	75.8	64.0	51.4	43.6	38.5	34.9	30.7			
				65.5	115	96.8	78.4	66.9	59.5	54.2	47.6			
				75.5	160	136	110	94.6	84.9	77.2	68.1			

[NOTE 1] Allowable torque based on worm speed (rpm).



Specifications	
Precision grade	KHK W 001 grade 1
Reference section of gear	Axial direction
Gear teeth	Standard full depth
Normal pressure angle	17°30'
Material	SCM440
Heat treatment	Thermal refined, gear teeth induction hardened*
Tooth hardness	50 to 60HRC
Surface treatment	Black oxide coated except for ground part

* Due to the gear teeth being induction hardened, no secondary operations can be performed on tooth areas including the bottom land (approx. 2 to 3 mm).

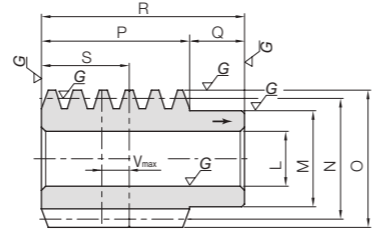

W4

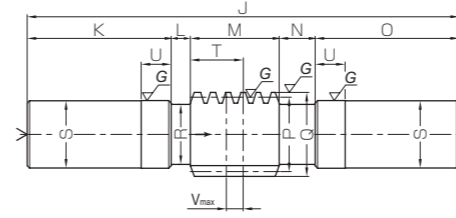

W6

Catalog Number	Nominal axial module	Number of Starts	Nominal lead angle	Direction of helix	Shape	Bore		Pitch dia.	Outside dia.	Face width	Hub width		Total length
						L _{H7}	M				N	O	
KWGDL2.5-R1	m2.5	1	3°52'	R	W4	18	30	37	42	48	17	65	
KWGDL3-R1	m3	1	3°54'	R	W4	20	35	44	50	54	20	74	

Position of reference tooth	Max. allowable shift	Weight (kg)	Catalog Number
S	V _{max}		
29	10	0.37	KWGDL2.5-R1
32	10	0.61	KWGDL3-R1

Catalog Number	Nominal axial module	Number of Starts	Nominal lead angle	Direction of helix	Shape	Total Length		Neck length (left)	Face width	Neck length (right)	Shaft length (R)		Pitch dia.
						J	K				L	M	
KWGDL2.5-R1	m2.5	1	3°52'	R	W6	260	85	16	48	26	85	37	
KWGDL3-R1	m3	1	3°54'	R	W6	300	100	18	54	28	100	44	

Outside dia.	Neck dia.	Shaft dia.	Position of reference tooth	Grinding length of shaft	Max. allowable shift	Weight (kg)	Catalog Number
Q	R	S	T	U	V _{max}		
42	30	36.2	29	25	10	2.00	KWGDL2.5-R1
50	34	40.2	32	25	10	2.95	KWGDL3-R1

[Caution on Product Characteristics] ① When adjusting the worm to reduce the backlash, V_{max} is the maximum amount of distance that you may shift it without causing problems with the gear mesh. V_{max} is not the recommended value to use for adjustment during assembly.

AGDL
Duplex Worm Wheels



Specifications	
Precision grade	KHK W 002 grade 1
Reference section of gear	Rotating plane
Gear teeth	Standard full depth
Normal pressure angle	17°30'
Material	CAC702 (old JIS A & BC2)
Heat Treatment	—
Tooth hardness	—

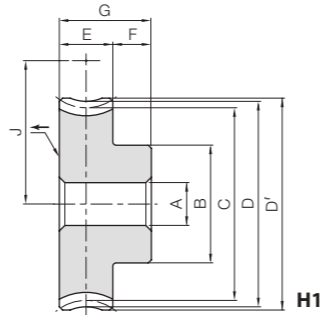

H1

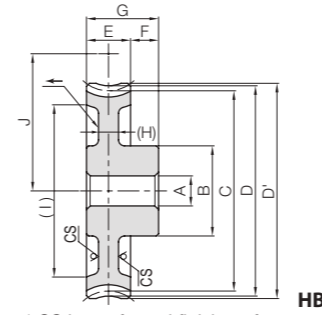

HB

* CS has a forged finish surface.



Catalog Number	Reduction ratio	Nominal transverse module	No. of teeth	Lead angle	Direction of helix	Shape	Bore		Hub dia.	Pitch dia.	Throat dia.	Outside dia.	Face width	Hub width	
							A _{H7}	B							C
AGDL2.5-36R1	36	m2.5	36	3°52'	R	H1	15	45	90	95	97.5	22	15		
AGDL2.5-40R1	40		HB			100								105	107.5
AGDL2.5-50R1	50		HB			125								130	132.5
AGDL2.5-60R1	60		HB			150								155	157.5
AGDL3-30R1	30	m3	30	3°54'	R	H1	20	55	90	96	99	28	17		
AGDL3-36R1	36		H1			108								114	117
AGDL3-40R1	40		HB			120								126	129
AGDL3-50R1	50		HB			150								156	159
AGDL3-60R1	60		HB			180								186	189

Total length	Web thickness	Web O.D.	Mounting distance	Allowable torque (N·m) <small>NOTE 1</small>								Backlash (mm)	Weight (kg)	Catalog Number
				30 _{rpm}	100 _{rpm}	300 _{rpm}	600 _{rpm}	900 _{rpm}	1200 _{rpm}	1800 _{rpm}				
37	G	(H)	(I)	J	113	94.5	75.5	63.8	56.0	51.0	44.3	0±0.045	1.25	AGDL2.5-36R1
					138	115	92.4	78.3	68.8	62.7	54.4			
					208	174	141	120	106	97.3	84.3			
					291	245	198	170	152	139	121			
45	G	(H)	(I)	J	137	114	90.0	74.7	65.5	59.5	51.2	0±0.045	1.65	AGDL3-30R1
					193	160	128	107	93.8	85.6	73.4			
					235	195	157	131	115	105	90.1			
					355	295	239	202	178	163	140			
					497	415	336	285	254	233	200			

[NOTE 1] Allowable torque based on worm speed (rpm).

[Caution on Product Characteristics] ① For duplex worm gears, mount the worm and wheel with the arrows pointing in the same direction. The arrows on the wheels indicate the direction of assembly and do not determine the direction of rotation. See assembly instructions on page 404.



Specifications	
Precision grade	KHK W 001 grade 1
Reference section of gear	Axial direction
Gear teeth	Standard full depth
Normal pressure angle	17°30'
Material	SCM440
Heat treatment	Thermal refined, gear teeth induction hardened*
Tooth hardness	50 to 60HRC
Surface treatment	Black oxide coated except for ground part

* Due to the gear teeth being induction hardened, no secondary operations can be performed on tooth areas including the bottom land (approx. 2 to 3 mm).

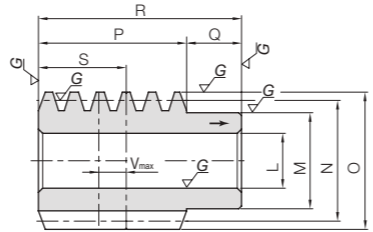

W4

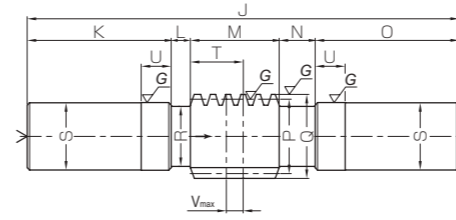

W6

Catalog Number	Nominal axial module	Number of Starts	Nominal lead angle	Direction of helix	Shape	Bore		Pitch dia.	Outside dia.	Face width	Hub width		Total length
						L _{H7}	M				N	O	
KWGDL3.5-R1	m3.5	1	3°47'	R	W4	24	44	53	60	62	23	85	
KWGDL4-R1	m4	1	3°41'	R	W4	28	50	62	70	74	26	100	

Position of reference tooth	Max. allowable shift	Weight (kg)	Catalog Number
S	V _{max}		
37	12	1.05	KWGDL3.5-R1
44	14	1.67	KWGDL4-R1

Catalog Number	Nominal axial module	Number of Starts	Nominal lead angle	Direction of helix	Shape	Total Length		Neck length (left)	Face width	Neck length (right)	Shaft length (R)		Pitch dia.
						J	K				L	M	
KWGDL3.5-R1	m3.5	1	3°47'	R	W6	330	110	18	62	30	110	53	
KWGDL4-R1	m4	1	3°41'	R	W6	360	120	16	74	30	120	62	

Outside dia.	Neck dia.	Shaft dia.	Position of reference tooth	Grinding length of shaft	Max. allowable shift	Weight (kg)	Catalog Number
Q	R	S	T	U	V _{max}		
60	42	48.2	37	25	12	4.72	KWGDL3.5-R1
70	50	56.2	44	25	14	7.10	KWGDL4-R1

[Caution on Product Characteristics] ① When adjusting the worm to reduce the backlash, V_{max} is the maximum amount of distance that you may shift it without causing problems with the gear mesh. V_{max} is not the recommended value to use for adjustment during assembly.

AGDL
Duplex Worm Wheels



Specifications	
Precision grade	KHK W 002 grade 1
Reference section of gear	Rotating plane
Gear teeth	Standard full depth
Normal pressure angle	17°30'
Material	CAC702 (old JIS A & BC2) *
Heat treatment	—
Tooth hardness	—

*The hub material of H5 is S45C.

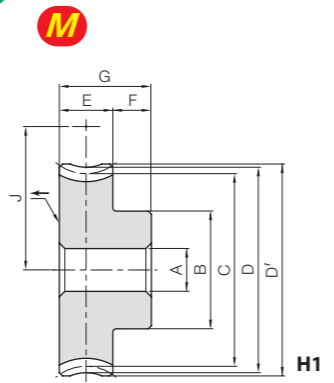

H1

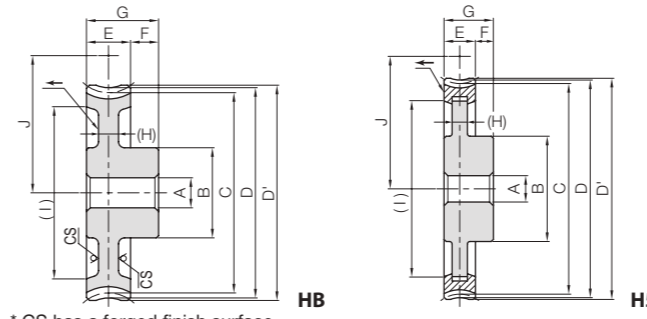

HB

H5

* CS has a forged finish surface.



Catalog Number	Reduction ratio	Nominal transverse module	No. of teeth	Lead angle	Direction of helix	Shape	Bore		Hub dia.	Pitch dia.	Throat dia.	Outside dia.	Face width	Hub width
							A _{H7}	B						
AGDL3.5-30R1	30	m3.5	30	3°47'	R	H1	20	60	105	112	115.5	32	18	
AGDL3.5-40R1 (Made to Order)	40	m3.5	40	3°47'	R	HB	20	70	140	147	150.5	32	18	
AGDL3.5-50R1	50	m3.5	50	3°47'	R	HB	20	80	175	182	185.5	32	18	
AGDL3.5-60R1	60	m3.5	60	3°47'	R	HB	20	90	210	217	220.5	32	18	
AGDL4-30R1 (Made to Order)	30	m4	30	3°41'	R	HB	20	65	120	128	132	35	20	
AGDL4-36R1 (Made to Order)	36	m4	36	3°41'	R	HB	20	75	144	152	156	35	20	
AGDL4-40R1	40	m4	40	3°41'	R	HB	20	75	160	168	172	35	20	
AGDL4-50R1	50	m4	50	3°41'	R	HB	20	90	200	208	212	35	20	
AGDL4-60R1	60	m4	60	3°41'	R	H5	30	120	240	248	252	35	20	

Total length	Web thickness	Web O.D.	Mounting distance	Allowable torque (N·m) ^{NOTE 1}							Backlash (mm)	Weight (kg)	Catalog Number
				30 rpm	100 rpm	300 rpm	600 rpm	900 rpm	1200 rpm	1800 rpm			
G	(H)	(I)	J	30 rpm	100 rpm	300 rpm	600 rpm	900 rpm	1200 rpm	1800 rpm			
50	—	—	79	208	172	136	111	98.1	88.3	75.7	0±0.045	2.51	AGDL3.5-30R1
50	(15)	(124)	96.5	356	295	236	196	173	156	133	0±0.045	3.34	AGDL3.5-40R1 (Made to Order)
50	(16)	(155)	114	538	446	360	301	267	243	207	0±0.045	5.02	AGDL3.5-50R1
50	(16)	(189)	131.5	753	627	506	425	381	345	296	0±0.045	6.87	AGDL3.5-60R1
55	(17)	(99)	91	284	234	184	150	132	118	101	0±0.045	3.01	AGDL4-30R1 (Made to Order)
55	(17)	(121)	103	400	329	262	215	190	170	144	0±0.045	4.18	AGDL4-36R1 (Made to Order)
55	(17)	(137)	111	486	400	320	264	233	208	177	0±0.045	4.78	AGDL4-40R1
55	(17)	(177)	131	735	605	488	405	361	324	275	0±0.045	7.07	AGDL4-50R1
55	(17)	(200)	151	1030	851	687	572	515	461	393	0±0.045	11.5	AGDL4-60R1

[NOTE 1] Allowable torque based on worm speed (rpm).

[Caution on Product Characteristics] ① For duplex worm gears, mount the worm and wheel with the arrows pointing in the same direction. The arrows on the wheels indicate the direction of assembly and do not determine the direction of rotation. See assembly instructions on page 404.

[Precautions for Made to Order Products] ① Prices and lead times for Made to Order products require separate estimates. Contact your dealer.



Specifications	
Precision grade	KHK W 001 grade 1
Reference section of gear	Axial direction
Gear teeth	Standard full depth
Normal pressure angle	17°30'
Material	SCM440
Heat treatment	Thermal refined, gear teeth induction hardened*
Tooth hardness	50 to 60HRC
Surface treatment	—

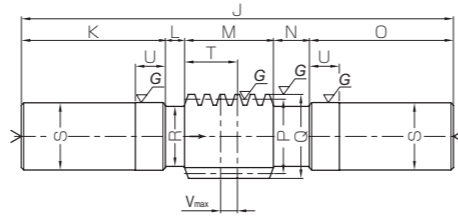

W6

Catalog Number	Nominal axial module	Number of Starts	Nominal lead angle	Direction of helix	Shape	Total Length		Shaft length (L)	Neck length (left)	Face width	Neck length (right)	Shaft length (R)	Pitch dia.
						J	K						
KWGDLS5-R1S	m5	1	4°05'	R	W6	400	130	17	90	33	130	70	
KWGDLS6-R1S	m6	1	4°17'	R	W6	400	120	18	105	37	120	80	

[Caution on Product Characteristics] ① When adjusting the worm to reduce the backlash, Vmax is the maximum amount of distance that you may shift it without causing problems with the gear mesh. Vmax is not the recommended value to use for adjustment during assembly.
② Products with S at the end of the catalog number are semi-custom stock products. See page 42 for lead times and allowable order quantities. See page 44 for other precautions.

Outside dia.	Neck dia.	Shaft dia.	Position of reference tooth	Grinding length of shaft	Max. allowable shift	Weight (kg)	Catalog Number
Q	R	S	T	U	Vmax		
80	54	60	53	30	16	9.39	KWGDLS5-R1S S
92	60	70	62	30	20	12.6	KWGDLS6-R1S S

AGDL
Duplex Worm Wheels **NEW**



Specifications	
Precision grade	KHK W 002 grade 1
Reference section of gear	Rotating plane
Gear teeth	Standard full depth
Normal pressure angle	17°30'
Material	CAC702 (old JIS A & BC2)
Heat treatment	—
Tooth hardness	—

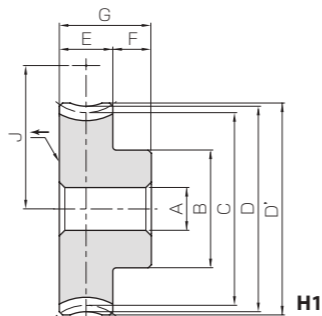

H1

Catalog Number	Reduction ratio	Nominal transverse module	No. of teeth	Lead angle	Direction of helix	Shape	Bore		Hub dia.	Pitch dia.	Throat dia.	Outside dia.	Face width	Hub width
							A _{H7}	B						
AGDL5-20R1S	20	m5	20	4°05'	R	H1	25	70	100	110	115	42	23	
AGDL5-30R1S	30		25				80							
AGDL5-40R1S	40		25				90							
AGDL5-50R1S	50		150				230							
AGDL5-60R1S	60		200				280							
AGDL6-20R1S	20	m6	20	4°17'	R	H1	30	85	120	132	138	46	24	
AGDL6-30R1S	30		30				90							
AGDL6-40R1S	40		130				220							
AGDL6-50R1S	50		190				280							
AGDL6-60R1S	60		250				340							

[Caution on Product Characteristics] ① For duplex worm gears, mount the worm and wheel with the arrows pointing in the same direction. The arrows on the wheels indicate the direction of assembly and do not determine the direction of rotation. See assembly instructions on page 404.
② Products with S at the end of the catalog number are semi-custom stock products. See page 42 for lead times and allowable order quantities. See page 44 for other precautions.
③ For S semi-custom standard products weighing 15 kg or more, eyebolt screw threads (2-M12 depth 25 mm) are machined around the outside of the hub side surface. Details of the PCD of the screw threads are located on page 51.



Total length	Mounting distance	Allowable torque (N·m) <small>NOTE 1</small>							Backlash (mm)	Weight (kg)	Catalog Number
		30 rpm	100 rpm	300 rpm	600 rpm	900 rpm	1200 rpm	1800 rpm			
G	J	30 rpm	100 rpm	300 rpm	600 rpm	900 rpm	1200 rpm	1800 rpm	0±0.045	3.17	AGDL5-20R1S S
65	85	243	195	152	122	106	94.8	78.6			
65	110	513	418	330	269	236	210	177	11.4	6.62	AGDL5-30R1S S
65	135	878	716	573	473	415	370	311			
65	160	1330	1080	875	726	641	575	482	11.5	11.5	AGDL5-40R1S S
47	185	1860	1520	1230	1030	915	819	690			
47	100	362	290	225	180	155	139	115	0±0.045	4.93	AGDL6-20R1S S
70	130	766	619	488	398	345	307	258			
70	160	1310	1060	848	700	607	543	453	12.7	10.2	AGDL6-30R1S S
51	190	1980	1610	1290	1070	938	843	703			
51	220	2770	2260	1820	1520	1340	1200	1010	16.8	12.7	AGDL6-40R1S S
51	220	2770	2260	1820	1520	1340	1200	1010			

[NOTE 1] Allowable torque based on worm speed (rpm).



Specifications	
Precision grade	KHK W 001 grade 2
Reference section of gear	Axial direction
Gear teeth	Standard full depth
Normal pressure angle	20°
Material	SCM440
Heat treatment	Thermal refined, gear teeth induction hardened*
Tooth hardness	50 to 60HRC

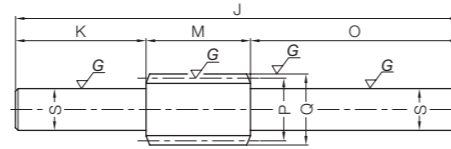

W5

* Due to the gear teeth being induction hardened, no secondary operations can be performed on tooth areas including the bottom land (approx. 2 to 3 mm).

Catalog Number	Axial module	Number of Starts	Nominal lead angle	Direction of helix	Shape	Total Length		Neck length (left)	Face width	Neck length (right)	Shaft length (R)	Pitch dia.
						J	K					
KWG0.5-R1 KWG0.5-R2	m0.5	1 2	3°11' 6°20'	R	W5	65	19	—	12	—	34	9
KWG0.8-R1 KWG0.8-R2	m0.8	1 2	3°49' 7°36'	R	W5	85	25	—	20	—	40	12

Outside dia.	Neck dia.	Shaft dia.	Grinding length of shaft	Weight (kg)	Catalog Number
Q	R	Sh7	U		
10	—	6	—	0.018	KWG0.5-R1 KWG0.5-R2
13.6	—	8	—	0.043	KWG0.8-R1 KWG0.8-R2



Specifications	
Precision grade	KHK W 002 grade 2
Reference section of gear	Rotating plane
Gear teeth	Standard full depth
Normal pressure angle	20°
Material	CAC702 (old JIS A & BC2)
Heat Treatment	—
Tooth hardness	—

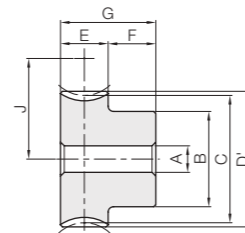

HA

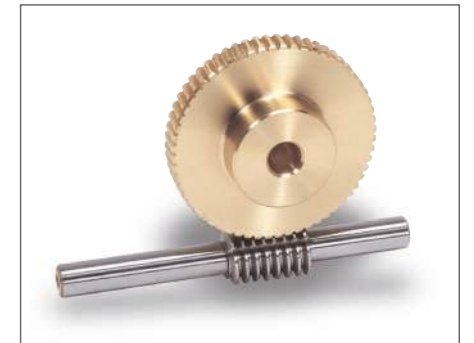

Catalog Number	Reduction ratio	Transverse module	No. of teeth	No. of starts of mating worm	Lead angle	Direction of helix	Shape	Bore	Hub dia.	Pitch dia.	Throat dia.	Outside dia.	Face width	Hub width						
								AH7	B	C	D	D'	E	F						
AG0.5-20R1 AG0.5-20R2	20 10	m0.5	20 20	1 2	3°11' 6°20'	R	HA	4 4	9 9	10 10	—	11 11	5	7						
AG0.5-30R1 AG0.5-40R1	30 40		30 40	1 1	3°11' 3°11'			4 5	12 15	15 20		16 21								
AG0.5-50R1 AG0.5-60R1	50 60		50 60	1 1	3°11' 3°11'			5 5	20 25	25 30		26 31								
AG0.8-20R1 AG0.8-20R2	20 10		m0.8	20 20	1 2			3°49' 7°36'	R	HA		5 5			12 12	16 16	—	17.6 17.6	8	8
AG0.8-30R1 AG0.8-30R2	30 15			30 30	1 2			3°49' 7°36'				5 5			18 18	24 24		25.6 25.6		
AG0.8-40R1 AG0.8-50R1	40 50			40 50	1 1			3°49' 3°49'				5 6			20 20	32		33.6 41.6		
AG0.8-60R1	60	60		1	3°49'	8	25	40			49.6									

Total length	Web thickness	Web O.D.	Mounting distance	Allowable torque (N·m) <small>NOTE 1</small>							Backlash (mm)	Weight (kg)	Catalog Number
				30 rpm	100 rpm	300 rpm	600 rpm	900 rpm	1200 rpm	1800 rpm			
12	—	—	9.5	0.52	0.44	0.36	0.30	0.26	0.24	0.21	0.02~0.12	0.0056	AG0.5-20R1 AG0.5-20R2 AG0.5-30R1 AG0.5-40R1 AG0.5-50R1 AG0.5-60R1
				0.51	0.42	0.33	0.27	0.24	0.22	0.19			
				1.09	0.94	0.77	0.65	0.58	0.53	0.48			
				1.86	1.60	1.34	1.15	1.02	0.94	0.84			
				2.82	2.42	2.05	1.77	1.58	1.46	1.30			
16	—	—	14	1.78	1.50	1.21	1.00	0.88	0.82	0.71	0.02~0.12	0.018	AG0.8-20R1 AG0.8-20R2 AG0.8-30R1 AG0.8-30R2 AG0.8-40R1 AG0.8-50R1 AG0.8-60R1
				1.76	1.44	1.11	0.91	0.80	0.74	0.63			
				3.77	3.21	2.62	2.20	1.96	1.81	1.61			
				3.75	3.14	2.46	2.02	1.80	1.65	1.45			
				6.45	5.49	4.55	3.87	3.46	3.19	2.83			
26	9.75	8.31	6.94	5.94	5.34	4.96	4.38	0.10	AG0.8-50R1				
				13.6	11.7	9.77	8.39			7.63	7.05	6.27	0.14

[NOTE 1] Allowable torque based on worm speed (rpm).



Specifications	
Precision grade	KHK W 001 grade 2
Reference section of gear	Axial direction
Gear teeth	Standard full depth
Normal pressure angle	20°
Material	SCM440
Heat treatment	Thermal refined, gear teeth induction hardened*
Tooth hardness	50 to 60HRC
Surface treatment	Black oxide coated except for ground part

* Due to the gear teeth being induction hardened, no secondary operations can be performed on tooth areas including the bottom land (approx. 2 to 3 mm).

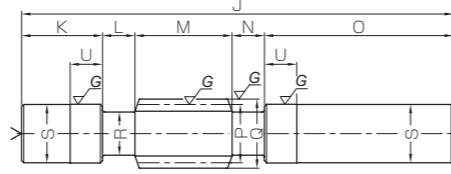

W6

Catalog Number	Axial module	Number of Starts	Nominal lead angle	Direction of helix	Shape	Total Length		Shaft length (L)		Face width	Neck length (right)		Shaft length (R)	Pitch dia.
						J	K	L	M		N	O		
KWG1-R1 KWG1-R2	m1	1 2	3°35' 7°08'	R	W6	140	35	10	30	10	55	16		
KWG1.5-R1 KWG1.5-R2	m1.5	1 2	3°26' 6°51'	R	W6	190	50	15	40	15	70	25		

Outside dia.	Neck dia.	Shaft dia.	Grinding length of shaft	Weight (kg)	Catalog Number
Q	R	S	U		
18	13	18.2	20	0.25	KWG1-R1 KWG1-R2
28	21	26.2	20	0.74	KWG1.5-R1 KWG1.5-R2

AG Module 1, 1.5
Worm Wheels



Specifications	
Precision grade	KHK W 002 grade 2*
Reference section of gear	Rotating plane
Gear teeth	Standard full depth
Normal pressure angle	20°
Material	CAC702 (old JIS A & BC2)
Heat Treatment	—
Tooth hardness	—

* The precision grade of J Series products is equivalent to the value shown in the table.

A _{H7}	Bore
B	Hub dia.
C	Pitch dia.
D	Throat dia.
D'	Outside dia.
E	Face width
F	Hub width
G	Total length
J	Mounting distance

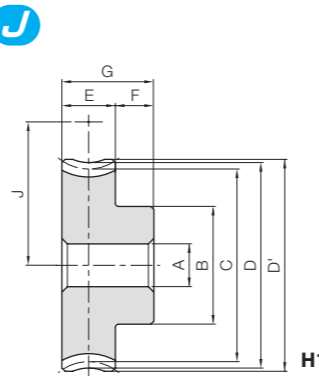

H1

Catalog Number	Reduction ratio	No. of teeth	No. of starts of mating worm	Lead angle of helix direction	Shape	A _{H7}	B	C	D	D'	E	F	G	J	Allowable torque (N·m) <small>NOTE 1</small>							Backlash (mm)	Weight (kg)
															30 rpm	100 rpm	300 rpm	600 rpm	900 rpm	1200 rpm	1800 rpm		
AG1-20R1	20	20	1	3°35'	R H1	6	16	20	22	23				18	3.35	2.79	2.23	1.83	1.63	1.50	1.30	0.04~0.14	0.038
AG1-20R2	10	20	2	7°08'		6	16	20	22	23				18	3.31	2.69	2.06	1.68	1.48	1.35	1.15		0.038
AG1-30R1	30	30	1	3°35'		6	20	30	32	33				23	7.08	5.98	4.84	4.05	3.63	3.31	2.92		0.078
AG1-30R2	15	30	2	7°08'		6	20	30	32	33	10	10	20	23	7.03	5.84	4.56	3.72	3.33	3.03	2.63		0.078
AG1-40R1	40	40	1	3°35'		8	26	40	42	43				28	12.1	10.2	8.43	7.12	6.38	5.86	5.13		0.13
AG1-50R1	50	50	1	3°35'		8	30	50	52	53				33	18.3	15.5	12.9	10.9	9.87	9.09	7.95		0.20
AG1-60R1	60	60	1	3°35'	10	35	60	62	63				38	25.6	21.8	18.1	15.4	14.1	12.9	11.4		0.29	
AG1.5-20R1	20	20	1	3°26'	R H1	8	22	30	33	34.5				27.5	9.84	8.18	6.40	5.30	4.68	4.25	3.68		0.10
AG1.5-20R2	10	20	2	6°51'		8	22	30	33	34.5				27.5	9.72	7.87	5.92	4.87	4.25	3.83	3.27		0.10
AG1.5-30R1	30	30	1	3°26'		10	30	45	48	49.5				35	20.8	17.5	13.9	11.7	10.4	9.40	8.28		0.22
AG1.5-30R2	15	30	2	6°51'		10	30	45	48	49.5	14	10	24	35	20.7	17.1	13.1	10.8	9.56	8.58	7.46		0.22
AG1.5-40R1	40	40	1	3°26'		12	35	60	63	64.5				42.5	35.6	30.0	24.2	20.6	18.3	16.6	14.6		0.37
AG1.5-50R1	50	50	1	3°26'		12	45	75	78	79.5				50	53.8	45.4	36.9	31.6	28.3	25.8	22.6		0.59
AG1.5-60R1	60	60	1	3°26'	12	50	90	93	94.5				57.5	75.3	63.8	51.9	44.7	40.4	36.7	32.4		0.83	

[NOTE 1] Allowable torque based on worm speed (rpm).

Worm Wheels

J Series

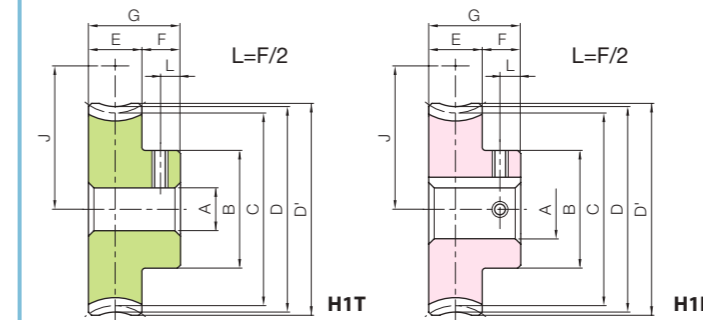

To order J Series products, please specify: **Catalog No. + J + BORE.**

Bore H7	* The product shapes of J Series items are identified by background color.															
	6	8	10	12	14	15	16	17	18	19	20	22	25	28	30	
Keyway JS9	—		4x1.8		5x2.3			6x2.8			8x3.3					
Screw size	—		4x1.8		5x2.3			6x2.8			8x3.3					
Catalog Number	M4	M5	M4			M5			M6							
AG1-20R1 J BORE																
AG1-20R2 J BORE																
AG1-30R1 J BORE																
AG1-30R2 J BORE																
AG1-40R1 J BORE																
AG1-50R1 J BORE																
AG1-60R1 J BORE																
AG1.5-20R1 J BORE																
AG1.5-20R2 J BORE																
AG1.5-30R1 J BORE																
AG1.5-30R2 J BORE																
AG1.5-40R1 J BORE																
AG1.5-50R1 J BORE																
AG1.5-60R1 J BORE																

[Caution on J series] ① Cancellation is not possible for made-to-order products. See page 42 for lead times and allowable order quantities. See page 44 for other precautions.



Specifications	
Precision grade	KHK W 001 grade 2
Reference section of gear	Axial direction
Gear teeth	Standard full depth
Normal pressure angle	20°
Material	SCM440
Heat treatment	Thermal refined, gear teeth induction hardened*
Tooth hardness	50 to 60HRC
Surface treatment	Black oxide coated except for ground part

* Due to the gear teeth being induction hardened, no secondary operations can be performed on tooth areas including the bottom land (approx. 2 to 3 mm).

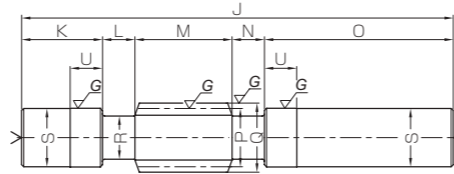

W6

* For products not categorized in our KHK Stock Gear series, custom gear production services with short lead times are available. Please see Page 26 for more details about custom-made orders.

Catalog Number	Axial module	Number of Starts	Nominal lead angle	Direction of helix	Shape	Total Length		Neck length (left)	Face width	Neck length (right)	Shaft length (R)	Pitch dia.
						J	K					
KWG2-R1	m2	1	5°12'	R	W6	200	35	25	40	25	75	22
KWG2-R2		2	10°18'			250	50	27	46	27	100	30
KWG2.5-R1	m2.5	1	4°46'	R	W6	250	50	27	46	27	100	30
KWG2.5-R2		2	9°28'			250	50	27	46	27	100	30

Outside dia.	Neck dia.	Shaft dia.	Grinding length of shaft	Weight (kg)	Catalog Number
Q	R	S	U		
26	17	25.2	20	0.64	KWG2-R1 KWG2-R2
35	23	30.2	20	1.27	KWG2.5-R1 KWG2.5-R2

AGF Module 2, 2.5
Worm Wheels



Specifications	
Precision grade	KHK W 002 grade 2
Reference section of gear	Rotating plane
Gear teeth	Standard full depth
Normal pressure angle	20°
Material	CAC702 (old JIS A & BC2) *
Heat treatment	—
Tooth hardness	—

* The hub material of H8 and H9 is FC200.

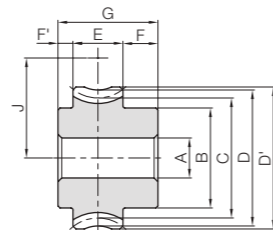

H6

Worm Wheels

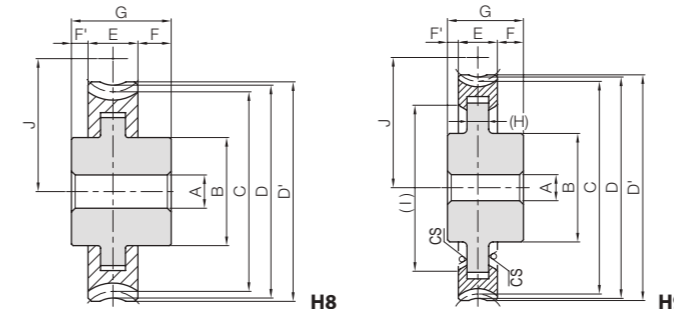

H8

H9

* CS has a forged finish surface.



Catalog Number	Reduction ratio	Transverse module	No. of teeth	No. of starts of mating worm	Profile shift coefficient	Lead angle	Direction of helix	Shape	Bore		Pitch dia.		Throat dia.		Outside dia.		Face width	Hub width (right)	Hub width (left)
									A _{H7}	B	C	D	D'	E	F	F'			
AGF2-20R1	20	m2	20	1	-0.5	5°12'	R	H6	12	32	40	42	44	18	12	5	E	F	F'
AGF2-20R2	10		20	2	-0.5	10°18'													
AGF2-30R1	30		30	1	-0.5	5°12'													
AGF2-30R2	15		30	2	-0.5	10°18'													
AGF2-36R1	36		36	1	0	5°12'													
AGF2-40R1	40		40	1	-0.5	5°12'													
AGF2-50R1	50	50	1	-0.5	5°12'	H9													
AGF2-60R1	60	60	1	-0.5	5°12'	H9													
AGF2.5-20R1	20	m2.5	20	1	0	4°46'	R	H6	12	35	50	55	57.5	20	15	5	E	F	F'
AGF2.5-20R2	10		20	2	9°28'														
AGF2.5-30R1	30		30	1	4°46'														
AGF2.5-30R2	15		30	2	9°28'														
AGF2.5-40R1	40		40	1	4°46'														
AGF2.5-50R1	50		50	1	4°46'	H9													
AGF2.5-60R1	60	60	1	4°46'	H9														

Total length	Web thickness	Web O.D.	Mounting distance	Allowable torque (N·m) NOTE 1								Backlash (mm)	Weight (kg)	Catalog Number
				30 rpm	100 rpm	300 rpm	600 rpm	900 rpm	1200 rpm	1800 rpm				
35	—	—	J	30	19.4	16.1	12.8	10.5	9.30	8.49	7.31	0.06~0.16	0.25	AGF2-20R1
				30	19.9	16.1	12.2	9.99	8.75	7.92	6.74			
				40	41.1	34.5	27.7	23.2	20.7	18.8	16.4			
				40	42.3	35.0	27.0	22.1	19.9	17.7	15.4			
				47	57.8	48.6	39.3	33.2	29.6	27.0	23.6			
40	—	—	J	50	70.3	59.2	48.1	40.7	36.4	33.2	28.9	0.06~0.16	0.85	AGF2-40R1
				60	106	89.5	73.4	62.5	56.2	51.5	44.9			
				60	106	89.5	73.4	62.5	56.2	51.5	44.9			
				70	149	126	103	88.4	80.3	73.3	64.2			
				65	127	106	85.4	72.4	63.7	57.9	50.5			
40	—	—	J	77.5	192	161	130	111	98.4	90.0	78.3	0.06~0.16	1.92	AGF2.5-50R1
				90	268	226	183	157	141	128	112			
				90	268	226	183	157	141	128	112			
				90	268	226	183	157	141	128	112			
				90	268	226	183	157	141	128	112			

[NOTE 1] Allowable torque based on worm speed (rpm).



Specifications	
Precision grade	KHK W 001 grade 2
Reference section of gear	Axial direction
Gear teeth	Standard full depth
Normal pressure angle	20°
Material	SCM440
Heat treatment	Thermal refined, gear teeth induction hardened*
Tooth hardness	50 to 60HRC
Surface treatment	Black oxide coated except for ground part

* Due to the gear teeth being induction hardened, no secondary operations can be performed on tooth areas including the bottom land (approx. 2 to 3 mm).

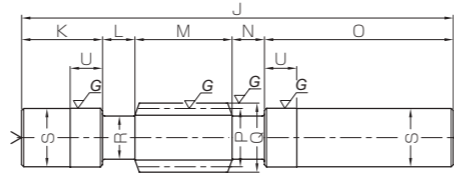

W6

* For products not categorized in our KHK Stock Gear series, custom gear production services with short lead times are available. Please see Page 26 for more details about custom-made orders.

Catalog Number	Axial module	Number of Starts	Nominal lead angle	Direction of helix	Shape	Total Length		Neck length (left)	Face width	Neck length (right)	Shaft length (R)	Pitch dia.
						J	K					
KWG3-R1	m3	1	4°31'	R	W6	300	55	30	60	30	125	38
KWG3-R2		2	8°58'									
KWG4-R1	m4	1	5°43'	R	W6	360	70	32.5	75	32.5	150	40
KWG4-R2		2	11°19'									

Outside dia.	Neck dia.	Shaft dia.	Grinding length of shaft	Weight (kg)	Catalog Number
Q	R	S	U		
44	30	40.2	25	2.66	KWG3-R1 KWG3-R2
48	29	45.2	25	3.85	KWG4-R1 KWG4-R2



Specifications	
Precision grade	KHK W 002 grade 2
Reference section of gear	Rotating plane
Gear teeth	Standard full depth
Normal pressure angle	20°
Material	CAC702 (old JIS A & BC2) *
Heat treatment	—
Tooth hardness	—

* The hub material of H8 and H9 is FC200.

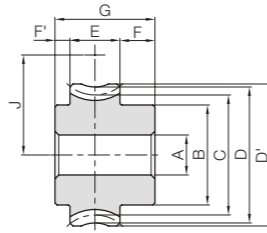

H6

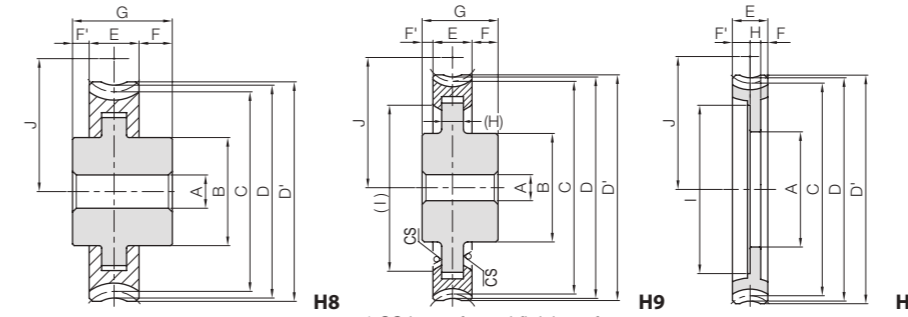

* CS has a forged finish surface.



Catalog Number	Reduction ratio	Transverse module	No. of teeth	No. of starts of mating worm	Profile shift coefficient	Lead angle	Direction of helix	Shape	Bore	Hub dia.	Pitch dia.	Throat dia.	Outside dia.	Face width	Hub width (right)	Hub width (left)	
									A _{H7}	B	C	D	D'	E	F	F'	
AGF3-20R1	20	m3	20	1	+0.333	4°31'	R	H6	20	50	60	68	71	25	17.5	7.5	
AGF3-20R2	10		20	2	+0.333	8°58'											
AGF3-25R1	25		25	1	0	4°31'											
AGF3-30R1	30		30	1	+0.333	4°31'											
AGF3-40R1	40		40	1	+0.333	4°31'											
AGF3-50R1	50	m3	50	1	+0.333	4°31'	R	H9	20	75	150	158	161	25	17.5	7.5	
AGF3-60R1	60		60							180	188	191					
AGF4-20R1	20	m4	20	1	0	5°43'	R	H6	20	60	80	88	92	30	20	10	
AGF4-20R2	10		20			2											11°19'
AGF4-25R1	25		25			1											5°43'
AGF4-30R1	30		30			1											5°43'
AGF4-30R2	15		30			2											11°19'
AGF4-40R1	40		40			1											5°43'
AGF4-50R1	50	50	200	208	212		20	10									
AGF4-60R1	60	60	240	248	252		7	15									

[Caution on Product Characteristics] ① For H0 products with bore of φ 190 or larger, the bore tolerance is H8.

Total length	Web thickness	Web O.D.	Mounting distance	Allowable torque (N·m) <small>NOTE 1</small>								Backlash (mm)	Weight (kg)	Catalog Number
				30 rpm	100 rpm	300 rpm	600 rpm	900 rpm	1200 rpm	1800 rpm				
G	(H)	(I)	J	30 rpm	100 rpm	300 rpm	600 rpm	900 rpm	1200 rpm	1800 rpm				
50	—	—	50	59.7	49.1	38.3	31.5	27.5	25.1	21.5	0.06~0.16	0.88	AGF3-20R1	
				60.2	48.2	36.1	29.5	25.4	23.0	19.4				
				90.2	74.3	58.8	48.9	42.6	39.0	33.5				
				126	105	83.1	69.6	61.0	55.4	48.2				
				216	180	145	122	108	98.0	84.9				
60	—	—	60	123	101	78.8	64.6	56.3	51.5	43.8	0.06~0.16	1.77	AGF4-20R1	
				127	101	76.0	61.9	53.2	48.3	40.5				
				186	153	121	100	87.3	79.9	68.5				
				260	216	171	143	125	114	98.4				
				270	220	168	137	120	108	92.2				
60	(20)	(128)	100	445	370	297	251	220	201	173	5.25	AGF4-40R1		
60	(20)	(168)	120	673	560	454	385	340	312	269	7.35	AGF4-50R1		
30	8	204	140	941	788	638	544	486	444	385	3.60	AGF4-60R1		

[NOTE 1] Allowable torque based on worm speed (rpm).



Specifications	
Precision grade	KHK W 001 grade 2
Reference section of gear	Axial direction
Gear teeth	Standard full depth
Normal pressure angle	20°
Material	SCM440
Heat treatment	Thermal refined, gear teeth induction hardened*
Tooth hardness	50 to 60HRC
Surface treatment	Black oxide coated except for ground part

* Due to the gear teeth being induction hardened, no secondary operations can be performed on tooth areas including the bottom land (approx. 2 to 3 mm).

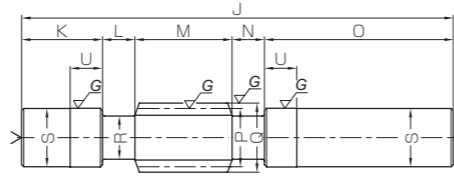

W6

Catalog Number	Axial module	Number of Starts	Nominal lead angle	Direction of helix	Shape	Total Length		Neck length (left)	Face width	Neck length (right)	Shaft length (R)	Pitch dia.
						J	K					
KWG5-R1	m5	1	5°43'	R	W6	400	75	30	90	30	175	50
KWG6-R1	m6	1	5°43'	R	W6	400	60	40	100	40	160	60

* For products not categorized in our KHK Stock Gear series, custom gear production services with short lead times are available. Please see Page 26 for more details about custom-made orders.

Outside dia.	Neck dia.	Shaft dia.	Grinding length of shaft	Weight (kg)	Catalog Number
Q	R	S	U		
60	36	50.2	30	5.75	KWG5-R1
72	44	60.2	30	8.09	KWG6-R1

AGF Module 5, 6
Worm Wheels



Specifications	
Precision grade	KHK W 002 grade 2
Reference section of gear	Rotating plane
Gear teeth	Standard full depth
Normal pressure angle	20°
Material	CAC702 (old JIS A & BC2) *
Heat treatment	—
Tooth hardness	—

* The hub material of H8 and H9 is FC200.

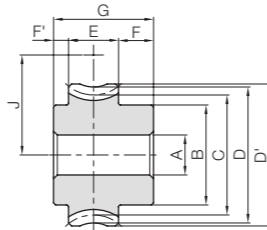

H6

Catalog Number	Reduction ratio	Transverse module	No. of teeth	No. of starts of mating worm	Profile shift coefficient	Lead angle	Direction of helix	Shape	Bore		Pitch dia.	Throat dia.	Outside dia.	Face width	Hub width (right)	Hub width (left)
									AH7	B						
AGF5-20R1	20	m5	20	1	0	5°43'	R	H6	75	100	110	115	35	23	12	
AGF5-30R1	30		75						150	160	165					
AGF5-40R1	40		110						200	210	215					
AGF5-50R1	50		250						260	265						
AGF5-60R1	60		300						310	315	7.5	17.5				
AGF6-20R1	20	m6	20	1	0	5°43'	R	H6	85	120	132	138	40	23	12	
AGF6-30R1	30		100						180	192	198					
AGF6-40R1	40		130						240	252	258					
AGF6-50R1	50		190						300	312	318					
AGF6-60R1	60		250						360	372	378	8				20

[Caution on Product Characteristics] ① For H0 products with bore of φ 190 or larger, the bore tolerance is H8.

Worm Wheels

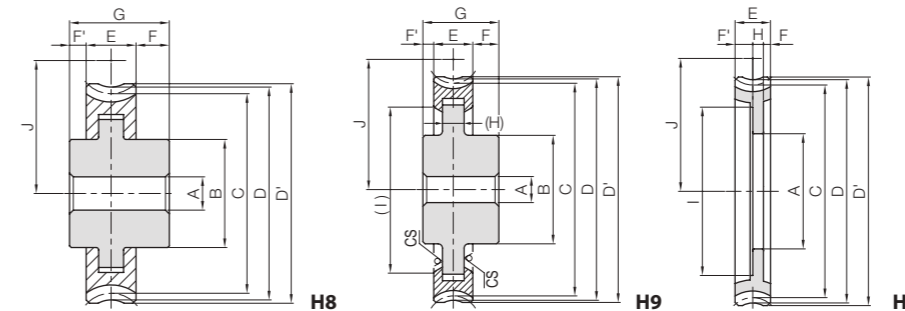

* CS has a forged finish surface.



Total length	Web thickness	Web O.D.	Mounting distance	Allowable torque (N·m) ^{NOTE 1}						Backlash (mm)	Weight (kg)	Catalog Number	
				30 rpm	100 rpm	300 rpm	600 rpm	900 rpm	1200 rpm				1800 rpm
70	—	—	75	211	172	134	108	95.0	86.2	72.7	0.07~0.19	3.26	AGF5-20R1
				446	369	291	239	211	191	164			
35	10	(26)	125	763	632	506	421	371	337	288	5.28	6.48	AGF5-30R1
				956	772	646	574	523	446				
75	—	—	90	329	268	208	167	146	131	110	0.07~0.19	4.95	AGF5-40R1
				696	572	451	368	325	290	248			
40	12	190	150	1190	981	784	648	572	513	436	8.00	10.0	AGF5-50R1
				1800	1480	1200	994	885	796	676			
40	12	310	210	2520	2090	1680	1410	1260	1130	969	10.0		AGF5-60R1

[NOTE 1] Allowable torque based on worm speed (rpm).



Specifications	
Precision grade	KHK W 001 grade 2*
Reference section of gear	Axial direction
Gear teeth	Standard full depth
Normal pressure angle	20°
Material	S45C
Heat treatment	Gear teeth induction hardened**
Tooth hardness	50 to 60HRC
Surface treatment	Black oxide coated except for ground part

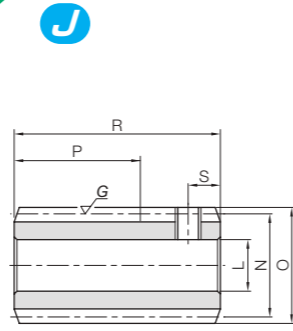

W2

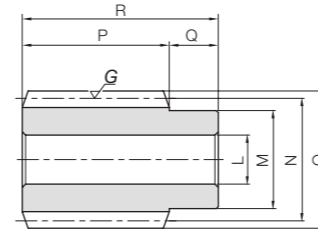

W1

J Series

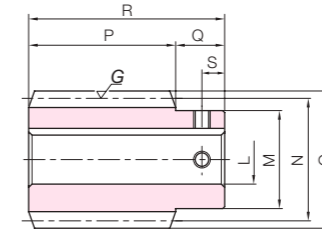

W1K



Catalog Number ● : J Series (Available-on-request)	Axial module	Number of Starts	Nominal lead angle	Direction of helix	Shape	Bore		Pitch dia.	Outside dia.	Face width	Hub width (right)		Hub width (left)
						LH7	M				N	O	
SWG1-R1 SWG1-R2	m1	1 2	3°35' 7°08'	R	W2	8	—	16	18	(20)	—	—	—
SWG1.5-R1 ● SWG1.5-R1J10	m1.5	1	3°26'	R	W1 W1K	10	20	25	28	30	10	—	—
SWG1.5-R2 ● SWG1.5-R2J10		2	6°51'		W1 W1K								

Total length	Keyway	Socket head screw	Weight (kg)	Catalog Number
R	Width × Depth	Size	S	● : J Series (Available-on-request)
32	—	M4	5	SWG1-R1 SWG1-R2
40	—	—	—	SWG1.5-R1
	4 x 1.8	M4	5	● SWG1.5-R1J10
40	—	—	—	SWG1.5-R2
	4 x 1.8	M4	5	● SWG1.5-R2J10

[Caution on J series] ① Cancellation is not possible for made-to-order products. See page 42 for lead times and allowable order quantities. See page 44 for other precautions.

AG Module 1, 1.5
Worm Wheels



Specifications	
Precision grade	KHK W 002 grade 2*
Reference section of gear	Rotating plane
Gear teeth	Standard full depth
Normal pressure angle	20°
Material	CAC702 (old JIS A & BC2)
Heat Treatment	—
Tooth hardness	—

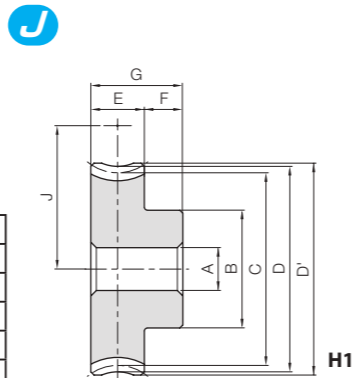

A _{H7}	Bore
B	Hub dia.
C	Pitch dia.
D	Throat dia.
D'	Outside dia.
E	Face width
F	Hub width
G	Total length
J	Mounting distance

* The precision grade of J Series products is equivalent to the value shown in the table.

J Series

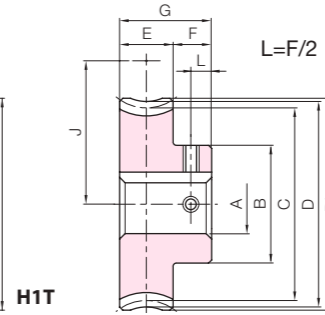
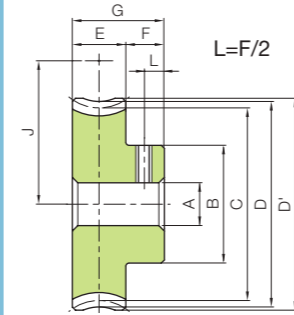

Worm Wheels

To order J Series products, please specify: **Catalog No. + J + BORE.**

Catalog Number	Reduction ratio	No. of teeth	No. of starts of mating worm	Lead angle helix direction	Shape	A _{H7}	B	C	D	D'	E	F	G	J	Allowable torque (N·m) <small>NOTE 1</small>							Backlash (mm)	Weight (kg)		
															30 rpm	100 rpm	300 rpm	600 rpm	900 rpm	1200 rpm	1800 rpm				
AG1-20R1	20	20	1	3°35'	R	H1	6	16	20	22	23				18	3.35	2.79	2.23	1.83	1.63	1.50	1.30	0.04~0.14	0.038	
AG1-20R2	10	20	2	7°08'			6	16	20	22	23					18	3.31	2.69	2.06	1.68	1.48	1.35			1.15
AG1-30R1	30	30	1	3°35'			6	20	30	32	33					23	7.08	5.98	4.84	4.05	3.63	3.31			2.92
AG1-30R2	15	30	2	7°08'			6	20	30	32	33	10	10	20		23	7.03	5.84	4.56	3.72	3.33	3.03			2.63
AG1-40R1	40	40	1	3°35'			8	26	40	42	43					28	12.1	10.2	8.43	7.12	6.38	5.86			5.13
AG1-50R1	50	50	1	3°35'			8	30	50	52	53					33	18.3	15.5	12.9	10.9	9.87	9.09			7.95
AG1-60R1	60	60	1	3°35'	10	35	60	62	63					38	25.6	21.8	18.1	15.4	14.1	12.9	11.4				
AG1.5-20R1	20	20	1	3°26'	R	H1	8	22	30	33	34.5				27.5	9.84	8.18	6.40	5.30	4.68	4.25	3.68	0.04~0.14	0.10	
AG1.5-20R2	10	20	2	6°51'			8	22	30	33	34.5					27.5	9.72	7.87	5.92	4.87	4.25	3.83			3.27
AG1.5-30R1	30	30	1	3°26'			10	30	45	48	49.5					35	20.8	17.5	13.9	11.7	10.4	9.40			8.28
AG1.5-30R2	15	30	2	6°51'			10	30	45	48	49.5	14	10	24		35	20.7	17.1	13.1	10.8	9.56	8.58			7.46
AG1.5-40R1	40	40	1	3°26'			12	35	60	63	64.5					42.5	35.6	30.0	24.2	20.6	18.3	16.6			14.6
AG1.5-50R1	50	50	1	3°26'			12	45	75	78	79.5					50	53.8	45.4	36.9	31.6	28.3	25.8			22.6
AG1.5-60R1	60	60	1	3°26'	12	50	90	93	94.5					57.5	75.3	63.8	51.9	44.7	40.4	36.7	32.4				

[NOTE 1] Allowable torque based on worm speed (rpm).

Bore H7	* The product shapes of J Series items are identified by background color.														
	6	8	10	12	14	15	16	17	18	19	20	22	25	28	30
Keyway JS9	—		4x1.8			5x2.3			6x2.8			8x3.3			
Screw size	—		4x1.8			5x2.3			6x2.8			8x3.3			
Catalog Number	M4	M5	M4			M5			M6						
AG1-20R1 J BORE															
AG1-20R2 J BORE															
AG1-30R1 J BORE															
AG1-30R2 J BORE															
AG1-40R1 J BORE															
AG1-50R1 J BORE															
AG1-60R1 J BORE															
AG1.5-20R1 J BORE															
AG1.5-20R2 J BORE															
AG1.5-30R1 J BORE															
AG1.5-30R2 J BORE															
AG1.5-40R1 J BORE															
AG1.5-50R1 J BORE															
AG1.5-60R1 J BORE															

[Caution on J series] ① Cancellation is not possible for made-to-order products. See page 42 for lead times and allowable order quantities. See page 44 for other precautions.



Specifications	
Precision grade	KHK W 001 grade 2*
Reference section of gear	Axial direction
Gear teeth	Standard full depth
Normal pressure angle	20°
Material	S45C
Heat treatment	Gear teeth induction hardened**
Tooth hardness	50 to 60HRC
Surface treatment	Black oxide coated except for ground part

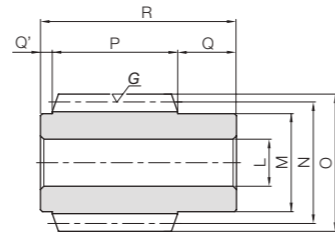

W3

J Series

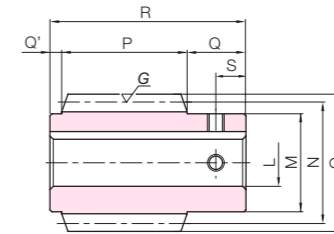

W3K



Catalog Number ● : J Series (Available-on-request)	Axial module	Number of Starts	Nominal lead angle	Direction of helix	Shape	Bore	Hub dia.	Pitch dia.	Outside dia.	Face width	Hub width (right)	Hub width (left)
						L _{H7}	M	N	O	P	Q	Q'
SWG2-R1 ● SWG2-R1J12 ● SWG2-R1J14	m2	1	3°41'	R	W3	12	25	31	35	32	15	3
W3K					12	14						
SWG2-R2 ● SWG2-R2J12 ● SWG2-R2J14	m2	2	7°21'	R	W3	12	25	31	35	32	15	3
W3K					12	14						
SWG2.5-R1 ● SWG2.5-R1J15 ● SWG2.5-R1J16 ● SWG2.5-R1J17	m2.5	1	3°52'	R	W3	15	30	37	42	45	17	3
W3K					15	16						
SWG2.5-R2 ● SWG2.5-R2J15 ● SWG2.5-R2J16 ● SWG2.5-R2J17	m2.5	2	7°42'	R	W3	15	30	37	42	45	17	3
W3K					15	16						

Total length R	Keyway Width × Depth	Socket head screw Size	Weight (kg)	Catalog Number ● : J Series (Available-on-request)	
				S	
50	—	—	0.21	—	SWG2-R1
	4 × 1.8	M4	0.21	7.5	● SWG2-R1J12
	5 × 2.3	M4	0.19	7.5	● SWG2-R1J14
65	—	—	0.21	—	SWG2-R2
	4 × 1.8	M4	0.21	7.5	● SWG2-R2J12
	5 × 2.3	M4	0.19	7.5	● SWG2-R2J14
65	—	—	0.40	—	SWG2.5-R1
	5 × 2.3	M4	0.39	8.5	● SWG2.5-R1J15
	5 × 2.3	M4	0.38	8.5	● SWG2.5-R1J16
65	—	—	0.37	—	● SWG2.5-R1J17
	5 × 2.3	M4	0.40	8.5	SWG2.5-R2
	5 × 2.3	M4	0.39	8.5	● SWG2.5-R2J15
65	—	—	0.38	—	● SWG2.5-R2J16
	5 × 2.3	M4	0.37	8.5	● SWG2.5-R2J17

[Caution on J series] ① Cancellation is not possible for made-to-order products. See page 42 for lead times and allowable order quantities. See page 44 for other precautions.

AG Module 2, 2.5
Worm Wheels



Specifications	
Precision grade	KHK W 002 grade 2*
Reference section of gear	Rotating plane
Gear teeth	Standard full depth
Normal pressure angle	20°
Material	CAC702 (old JIS A & BC2)**
Heat treatment	—
Tooth hardness	—

A _{H7}	Bore
B	Hub dia.
C	Pitch dia.
D	Throat dia.
D'	Outside dia.
E	Face width
F	Hub width
G	Total length
(H)	Web thickness
(I)	Web O.D.
J	Mounting distance

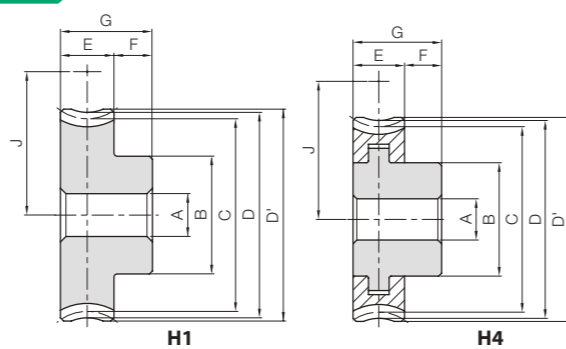

Catalog Number	Reduction ratio	No. of teeth	No. of starts of mating worm	Lead angle helix direction	Shape	A _{H7}	B	C	D	D'	E	F	G	(H)	(I)	J	Allowable torque (N·m) NOTE 1							Backlash (mm)	Weight (kg)			
																	30 rpm	100 rpm	300 rpm	600 rpm	900 rpm	1200 rpm	1800 rpm					
AG2-20R1	20	20	1	3°41'	H1	12	33	40	44	46	—	—	—	—	—	—	35.5	21.0	17.5	13.6	11.2	9.84	8.94	7.75	0.06~0.16	0.26		
AG2-20R2	10	20	2	7°21'	H1	12	33	40	44	46	—	—	—	—	—	—	35.5	20.7	16.8	12.6	10.3	8.93	8.05	6.89				
AG2-30R1	30	30	1	3°41'	H4	12	40	60	64	66	—	—	—	—	—	—	45.5	44.3	37.3	29.6	24.8	21.9	19.8	17.4	0.06~0.16	0.51		
AG2-30R2	15	30	2	7°21'	H4	12	40	60	64	66	—	—	—	—	—	—	45.5	44.0	36.5	27.8	22.8	20.1	18.0	15.7				
AG2-40R1	40	40	1	3°41'	H4	12	45	80	84	86	18	15	33	—	—	—	55.5	75.8	64.0	51.4	43.6	38.5	34.9	30.7	0.06~0.16	0.85		
AG2-50R1	50	50	1	3°41'	H5	15	50	100	104	106	—	—	—	—	—	—	(8)	(83)	65.5	115	96.8	78.4	66.9	59.5			54.2	47.6
AG2-60R1	60	60	1	3°41'	H5	15	55	120	124	126	—	—	—	—	—	—	(11)	(100)	75.5	160	136	110	94.6	84.9	77.2	68.1	1.52	
AG2.5-20R1	20	20	1	3°52'	H1	12	35	50	55	57.5	—	—	—	—	—	—	43.5	34.6	28.5	22.3	18.3	16.0	14.6	12.5	0.06~0.16	0.39		
AG2.5-20R2	10	20	2	7°42'	H1	12	35	50	55	57.5	—	—	—	—	—	—	43.5	34.2	27.4	20.6	16.8	14.5	13.1	11.1				
AG2.5-30R1	30	30	1	3°52'	H4	12	40	75	80	82.5	—	—	—	—	—	—	56	73.2	61.0	48.3	40.5	35.5	32.2	28.1	0.06~0.16	0.79		
AG2.5-30R2	15	30	2	7°42'	H4	12	40	75	80	82.5	—	—	—	—	—	—	56	72.7	59.6	45.5	37.2	32.6	29.4	25.3				
AG2.5-40R1	40	40	1	3°52'	H5	15	45	100	105	107.5	20	14	34	—	—	—	(11)	(81)	68.5	125	105	84.0	71.2	62.5	57.0	49.5	0.06~0.16	1.11
AG2.5-50R1	50	50	1	3°52'	H5	15	55	125	130	132.5	—	—	—	—	—	—	(12)	(106)	81	189	158	128	109	96.7	88.5	76.7		
AG2.5-60R1	60	60	1	3°52'	H5	15	60	150	155	157.5	—	—	—	—	—	—	(12)	(130)	93.5	265	222	180	154	138	126	110	2.32	

[NOTE 1] Allowable torque based on worm speed (rpm).

Worm Wheels

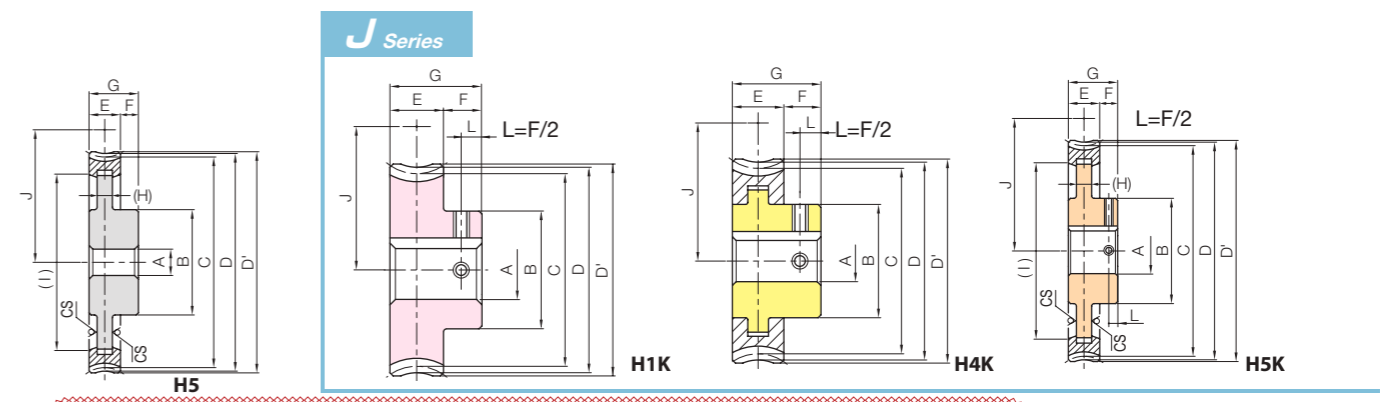

To order J Series products, please specify: **Catalog No. + J + BORE.**

Bore H7	* The product shapes of J Series items are identified by background color.														
	12	14	15	16	17	18	19	20	22	25	28	30	32	35	
Keyway J _{s9}	4×1.8			5×2.3				6×2.8			8×3.3			10×3.3	
Screw size	M4			M5				M6			M8				
Catalog Number	AG2-20R1 J BORE			AG2-20R2 J BORE				AG2-30R1 J BORE			AG2-30R2 J BORE			AG2-40R1 J BORE	
	AG2-50R1 J BORE			AG2-60R1 J BORE				AG2.5-20R1J BORE			AG2.5-20R2J BORE			AG2.5-30R1J BORE	
	AG2.5-30R2J BORE			AG2.5-40R1J BORE				AG2.5-50R1J BORE			AG2.5-60R1J BORE				

[Caution on J series] ① Cancellation is not possible for made-to-order products. See page 42 for lead times and allowable order quantities. See page 44 for other precautions.



Specifications	
Precision grade	KHK W 001 grade 2*
Reference section of gear	Axial direction
Gear teeth	Standard full depth
Normal pressure angle	20°
Material	S45C
Heat treatment	Gear teeth induction hardened**
Tooth hardness	50 to 60HRC
Surface treatment	Black oxide coated except for ground part

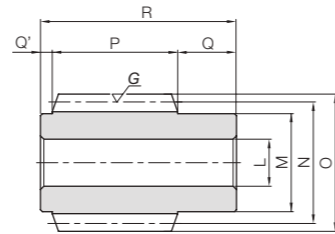

W3

J Series

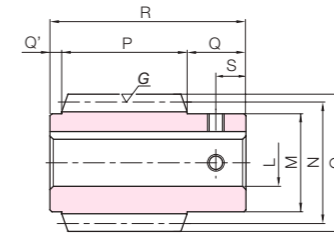

W3K



Catalog Number ● : J Series (Available-on-request)	Axial module	Number of Starts	Nominal lead angle	Direction of helix	Shape	Bore		Pitch dia.	Outside dia.	Face width	Hub width (right)	Hub width (left)
						LH7	M					
SWG3-R1 ● SWG3-R1J17 ● SWG3-R1J18 ● SWG3-R1J19 ● SWG3-R1J20	m3	1	3°54'	R	W3	16	35	44	50	50	20	4
W3K						17						
SWG3-R2 ● SWG3-R2J17 ● SWG3-R2J18 ● SWG3-R2J19 ● SWG3-R2J20	m3	2	7°46'	R	W3	16	35	44	50	50	20	4
W3K						17						
SWG4-R1 SWG4-R2	m4	1 2	3°41' 7°21'	R	W3	22	50	62	70	70	25	5

Total length R	Keyway Width × Depth	Socket head screw		Weight (kg)	Catalog Number ● : J Series (Available-on-request)
		Size	S		
74	—	—	—	0.66	SWG3-R1
	5 × 2.3	M4	10	0.64	● SWG3-R1J17
	6 × 2.8	M5	10	0.62	● SWG3-R1J18
	6 × 2.8	M5	10	0.60	● SWG3-R1J19
	6 × 2.8	M5	10	0.58	● SWG3-R1J20
100	—	—	—	1.82	SWG3-R2
	5 × 2.3	M4	10	0.66	● SWG3-R2J17
	6 × 2.8	M5	10	0.62	● SWG3-R2J18
	6 × 2.8	M5	10	0.60	● SWG3-R2J19
	6 × 2.8	M5	10	0.58	● SWG3-R2J20

[Caution on J series] ① Cancellation is not possible for made-to-order products. See page 42 for lead times and allowable order quantities. See page 44 for other precautions.

AG Module 3, 4
Worm Wheels



Specifications	
Precision grade	KHK W 002 grade 2*
Reference section of gear	Rotating plane
Gear teeth	Standard full depth
Normal pressure angle	20°
Material	CAC702 (old JIS A & BC2)**
Heat treatment	—
Tooth hardness	—

AH7	Bore
B	Hub dia.
C	Pitch dia.
D	Throat dia.
D'	Outside dia.
E	Face width
F	Hub width
G	Total length
(H)	Web thickness
(I)	Web O.D.
J	Mounting distance

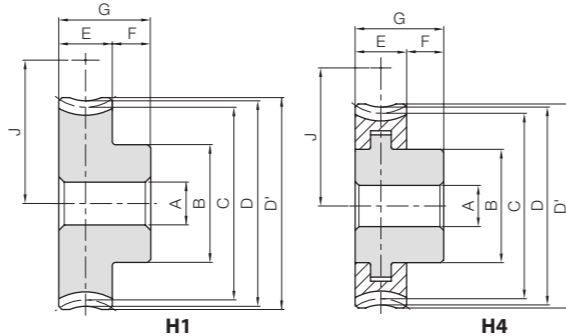

H1

H4

J Series

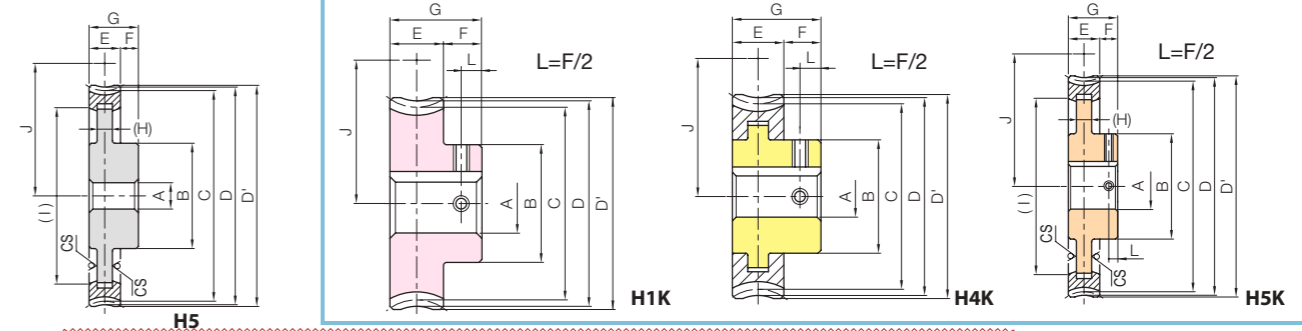

H5

H1K

H4K

H5K

To order J Series products, please specify: **Catalog No. + J + BORE.**

Catalog Number	Reduction ratio	No. of teeth	No. of starts of mating worm	Lead angle helix direction	Shape	AH7	B	C	D	D'	E	F	G	(H)	(I)	J	Allowable torque (N·m) NOTE 1							Backlash (mm)	Weight (kg)		
																	30 rpm	100 rpm	300 rpm	600 rpm	900 rpm	1200 rpm	1800 rpm				
																	30 rpm	100 rpm	300 rpm	600 rpm	900 rpm	1200 rpm	1800 rpm				
AG3-20R1	20	20	1	3°54'	H1	20	50	60	66	69	—	—	—	—	—	52	59.5	48.8	38.0	30.9	27.0	24.7	20.9	0.75	0.06~0.16	2.03	
AG3-20R2	10	20	2	7°46'	H1	20	50	60	66	69	—	—	—	—	52	58.7	46.9	35.1	28.4	24.5	22.2	18.5	0.75				
AG3-30R1	30	30	1	3°54'	H4	20	55	90	96	99	—	—	—	—	67	126	104.3	82.4	68.4	59.9	54.5	46.9	1.46				
AG3-30R2	15	30	2	7°46'	H4	20	55	90	96	99	—	—	—	—	67	125	102	77.6	62.8	55.1	49.7	42.2	1.46				
AG3-40R1	40	40	1	3°54'	H5	20	65	120	126	129	25	18	43	(10)	(103)	82	215	179	143	120	106	96.4	82.5	2.03			
AG3-50R1	50	50	1	3°54'	H5	20	75	150	156	159	(15)	(130)	97	(15)	(155)	112	455	380	308	261	233	213	183	3.22			
AG3-60R1	60	60	1	3°54'	H5	20	85	180	186	189	(15)	(155)	112	(15)	(155)	112	455	380	308	261	233	213	183	4.52			
AG4-20R1	20	20	1	3°41'	H1	20	60	80	88	92	—	—	—	—	71	115	93.6	72.7	58.2	51.1	45.7	38.4	1.53	0.06~0.16			3.00
AG4-20R2	10	20	2	7°21'	H1	20	60	80	88	92	—	—	—	—	71	114	90.0	67.2	53.5	46.4	41.2	34.1	1.53				
AG4-30R1	30	30	1	3°41'	H4	20	65	120	128	132	—	—	—	—	91	244	200	158	129	114	101	86.3	3.00				
AG4-30R2	15	30	2	7°21'	H4	20	65	120	128	132	—	—	—	—	91	242	196	148	118	104	92.2	77.6	3.00				
AG4-40R1	40	40	1	3°41'	H5	20	80	160	168	172	(15)	(133)	111	(15)	(133)	111	417	343	274	226	200	179	152		4.32		
AG4-50R1	50	50	1	3°41'	H5	20	90	200	208	212	(16)	(173)	131	(16)	(173)	131	630	519	418	347	309	277	236		6.25		
AG4-60R1	60	60	1	3°41'	H5	20	100	240	248	252	(17)	(210)	151	(17)	(210)	151	881	730	589	491	441	395	337		8.74		

[NOTE 1] Allowable torque based on worm speed (rpm).

[Caution on J series] ① Cancellation is not possible for made-to-order products. See page 42 for lead times and allowable order quantities. See page 44 for other precautions.

Bore H7	* The product shapes of J Series items are identified by background color.									
	20	22	25	28	30	32	35	40	45	50
Keyway Js9	20	22	25	28	30	32	35	40	45	50
Screw size	6×2.8		8×3.3			10×3.3		12×3.3		14×3.8
Catalog Number	M5			M6			M8			M10
AG3-20R1 J BORE	[Color-coded cells]									
AG3-20R2 J BORE	[Color-coded cells]									
AG3-30R1 J BORE	[Color-coded cells]									
AG3-30R2 J BORE	[Color-coded cells]									
AG3-40R1 J BORE	[Color-coded cells]									
AG3-40R2 J BORE	[Color-coded cells]									
AG3-50R1 J BORE	[Color-coded cells]									
AG3-50R2 J BORE	[Color-coded cells]									
AG3-60R1 J BORE	[Color-coded cells]									

[Caution on J series] ① Cancellation is not possible for made-to-order products. See page 42 for lead times and allowable order quantities. See page 44 for other precautions.



Specifications	
Precision grade	KHK W 001 grade 2
Reference section of gear	Axial direction
Gear teeth	Standard full depth
Normal pressure angle	20°
Material	S45C
Heat treatment	Gear teeth induction hardened *
Tooth hardness	50 to 60HRC
Surface treatment	Black oxide coated except for ground part

* Due to the gear teeth being induction hardened, no secondary operations can be performed on tooth areas including the bottom land (approx. 2 to 3 mm).

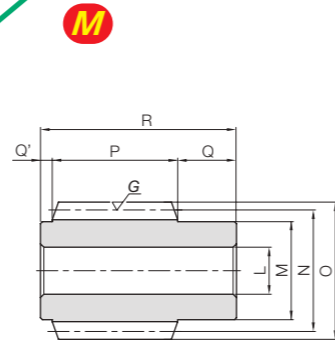

W3

Catalog Number	Axial module	Number of Starts	Nominal lead angle	Direction of helix	Shape	Bore		Pitch dia.	Outside dia.	Face width	Hub width (right)		Hub width (left)
						L _{H7}	M				N	O	
SWG5-R1	m5	1	4°05'	R	W3	25	56	70	80	85	30	5	
SWG5-R2		2	8°08'			30	63	80	92	100	35	5	
SWG6-R1	m6	1	4°17'	R	W3	30	63	80	92	100	35	5	
SWG6-R2 (Made to Order)		2	8°32'			30	63	80	92	100	35	5	

[Precautions for Made to Order Products] Prices and lead times for Made to Order products require separate estimates. Contact your dealer.

Total length	Socket head screw		Weight (kg)	Catalog Number
R	Size	S		
120	—	—	2.78	SWG5-R1 SWG5-R2
140	—	—	4.15	SWG6-R1
140	—	—	4.15	SWG6-R2 (Made to Order)

AG Module 5, 6
Worm Wheels



Specifications	
Precision grade	KHK W 002 grade 2
Reference section of gear	Rotating plane
Gear teeth	Standard full depth
Normal pressure angle	20°
Material	CAC702 (old JIS A & BC2) *
Heat treatment	—
Tooth hardness	—

* The hub material of H4 and H5 is FC200.

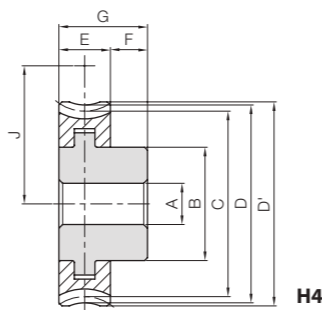

H4

Catalog Number	Reduction ratio	Transverse module	No. of teeth	No. of starts of mating worm	Lead angle	Direction of helix	Shape	Bore		Pitch dia.	Throat dia.	Outside dia.	Face width
								A _{H7}	B				
AG5-20R1	20	m5	20	1	4°05'	R	H4	75	100	110	115	35	
AG5-20R2	10		H4	75	100		110	115					
AG5-30R1	30		H5	75	150		160	165					
AG5-30R2	15		H5	75	150		160	165					
AG5-40R1	40		H5	110	200		210	215					
AG5-50R1	50	m6	50	1	4°05'	H5	120	250	260	265	40		
AG5-60R1	60		H5	130	300	310	315						
AG6-20R1	20	m6	20	1	4°17'	R	H4	25	85	120	132	138	
AG6-20R2 (Made to Order)	10		H4	25	85	120	132	138					
AG6-30R1	30		H5	25	100	180	192	198					
AG6-30R2 (Made to Order)	15		H5	25	100	180	192	198					
AG6-40R1	40		H5	25	120	240	252	258					
AG6-50R1	50		H5	50	1	4°17'	R	25	130	300	312	318	40
AG6-60R1	60			H5	60	1	4°17'	25	150	360	372	378	

[Precautions for Made to Order Products] ① Prices and lead times for Made to Order products require separate estimates. Contact your dealer.

Worm Wheels

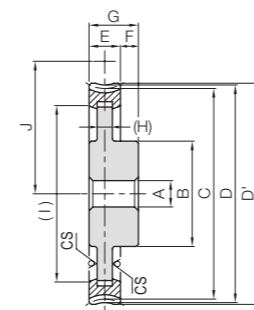

H5



Hub width	Total length	Web thickness	Web O.D.	Mounting distance	Allowable torque (N·m) ^{NOTE 1}								Backlash (mm)	Weight (kg)	Catalog Number
					30 _{rpm}	100 _{rpm}	300 _{rpm}	600 _{rpm}	900 _{rpm}	1200 _{rpm}	1800 _{rpm}				
25	60	—	—	85	202	163	127	101	88.4	79.0	65.5	0.07~0.19	2.79	AG5-20R1	
		—	—	85	200	157	117	93.2	80.2	71.1	58.1				4.75
		(21)	(120)	110	427	348	275	224	196	175	147				
		(21)	(120)	110	425	340	259	206	180	159	132				
		(23)	(168)	135	731	597	478	394	346	309	259				
(23)	(168)	135	731	597	478	394	346	309	259	17.6	AG5-60R1				
30	70	—	—	100	315	252	196	157	135			121	99.6	0.07~0.19	4.53
30	70	—	—	100	314	244	182	145	124	110	89.3	0.07~0.19	4.53	AG6-20R2 (Made to Order)	
30	70	(26)	(142)	130	666	538	424	346	300	267	224	0.07~0.19	8.52	AG6-30R1	
30	70	(26)	(142)	130	668	532	403	321	278	246	203	0.07~0.19	8.52	AG6-30R2 (Made to Order)	
30	70	(30)	(200)	160	1140	923	738	609	528	472	394	0.07~0.19	14.2	AG6-40R1	
30	70	(30)	(258)	190	1720	1400	1130	935	816	733	611	0.07~0.19	21.0	AG6-50R1	
					2410	1960	1580	1320	1170	1040	875				29.7

[NOTE 1] Allowable torque based on worm speed (rpm).



Specifications	
Precision grade	KHK W 001 grade 4
Reference section of gear	Normal plane
Gear teeth	Standard full depth
Normal pressure angle	20°
Material	S45C
Heat treatment	—
Tooth hardness	(less than 194HB)
Surface treatment	Black oxide coating

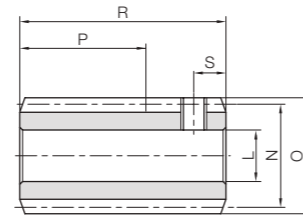

W2

Catalog Number	Normal module	Number of Starts	Nominal lead angle	Direction of helix	Shape	Bore	Hub dia.	Pitch dia.	Outside dia.	Face width	Hub width (right)	Hub width (left)
						L _{H8}	M	N	O	P	Q	Q'
SW0.5-R1	m0.5	1	2°36'	R	W2	5	—	11	12	(10)	—	—
SW0.5-R2		2	5°13'									
SW0.8-R1	m0.8	1	3°17'	R	W2	6	—	14	15.6	(18)	—	—
SW0.8-R2		2	6°34'									

Total length	Socket head screw		Weight (kg)	Catalog Number
	R	Size		
18	M3	3	0.010	SW0.5-R1 SW0.5-R2
30	M4	5	0.029	SW0.8-R1 SW0.8-R2

BG Module 0.5, 0.8
Worm Wheels

Bronze Worm Wheels



Specifications	
Precision grade	KHK W 002 grade 4
Reference section of gear	Normal plane
Gear teeth	Standard full depth
Normal pressure angle	20°
Material	CAC502 (old JIS PBC2)
Heat Treatment	—
Tooth hardness	—

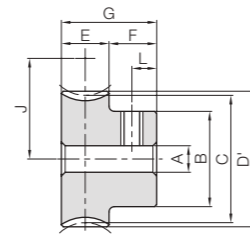

HAT

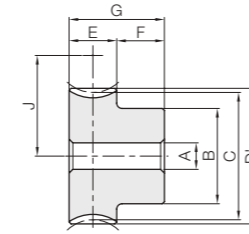

HA



Catalog Number	Reduction ratio	Normal module	No. of teeth	No. of starts of mating worm	Lead angle	Direction of helix	Shape	Bore	Hub dia.	Pitch dia.	Throat dia.	Outside dia.	Face width
								A _{H7}	B	C	D	D'	E
BG0.5-20R1	20	m0.5	20	1	2°36'	R	HAT	4	9	10.01	—	11	5
BG0.5-20R2	10		20	2	5°13'			4	9	10.04		11	
BG0.5-30R1	30		30	1	2°36'			4	12	15.02		16	
BG0.5-30R2	15		30	2	5°13'			4	12	15.06		16	
BG0.5-40R1	40		40	1	2°36'			5	15	20.02		21	
BG0.5-50R1	50		50	1	2°36'			5	20	25.03		26	
BG0.5-60R1	60	60	1	2°36'	5	25	30.03	31					

Hub width	Total length	Mounting distance	Socket head screw		Allowable torque (N·m) ^{NOTE 1}						Backlash (mm)	Weight (kg)	Catalog Number
			Size	L	30 _{rpm}	100 _{rpm}	300 _{rpm}	600 _{rpm}	900 _{rpm}	1200 _{rpm}			
7	12	J	M3	3.5	0.27	0.23	0.19	0.15	0.14	0.13	0~0.16	0.0061	BG0.5-20R1 BG0.5-20R2 BG0.5-30R1 BG0.5-30R2 BG0.5-40R1
					0.28	0.23	0.18	0.15	0.13	0.12			
					0.58	0.50	0.41	0.34	0.30	0.28			
					0.59	0.49	0.39	0.32	0.29	0.26			
					0.99	0.85	0.71	0.60	0.54	0.50			
					1.50	1.28	1.08	0.92	0.83	0.77			
2.10	1.80	1.52	1.31	1.19	1.09	0.039	BG0.5-50R1						
											0.059	BG0.5-60R1	

Catalog Number	Reduction ratio	Normal module	No. of teeth	No. of starts of mating worm	Lead angle	Direction of helix	Shape	Bore	Hub dia.	Pitch dia.	Throat dia.	Outside dia.	Face width
								A _{H7}	B	C	D	D'	E
BG0.8-20R1	20	m0.8	20	1	3°17'	R	HA	5	12	16.03	—	17.6	9
BG0.8-20R2	10		20	2	6°34'			5	12	16.11		17.6	
BG0.8-30R1	30		30	1	3°17'			5	18	24.04		25.6	
BG0.8-30R2	15		30	2	6°34'			5	18	24.16		25.6	
BG0.8-40R1	40		40	1	3°17'			6	20	32.05		33.6	
BG0.8-50R1	50		50	1	3°17'			8	25	40.06		41.6	
BG0.8-60R1	60	60	1	3°17'	8	25	48.08	49.6					

Hub width	Total length	Mounting distance	Allowable torque (N·m) ^{NOTE 1}						Backlash (mm)	Weight (kg)	Catalog Number	
			30 _{rpm}	100 _{rpm}	300 _{rpm}	600 _{rpm}	900 _{rpm}	1200 _{rpm}				
9	18	J	15	1.05	0.88	0.71	0.58	0.52	0.48	0.04~0.22	0.023	BG0.8-20R1 BG0.8-20R2 BG0.8-30R1 BG0.8-30R2 BG0.8-40R1
			15	1.06	0.86	0.66	0.54	0.48	0.44			
			19	2.23	1.89	1.53	1.29	1.15	1.06			
			19	2.24	1.87	1.46	1.20	1.07	0.98			
			23	3.81	3.24	2.67	2.26	2.02	1.87			
			27	5.76	4.90	4.07	3.47	3.13	2.90			
										0.13	BG0.8-50R1	
										0.18	BG0.8-60R1	

[Caution on Product Characteristics] ① The worm wheel is shifted to fit the mounting distance.

[NOTE 1] Allowable torque based on worm speed (rpm).



Specifications	
Precision grade	KHK W 001 grade 4
Reference section of gear	Normal plane
Gear teeth	Standard full depth
Normal pressure angle	20°
Material	S45C
Heat treatment	—
Tooth hardness	(less than 194HB)
Surface treatment	Black oxide coating

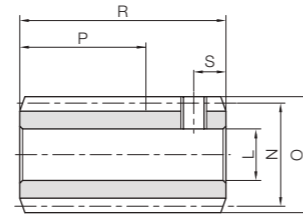

W2

Catalog Number	Normal module	Number of Starts	Nominal lead angle	Direction of helix	Shape	Bore	Hub dia.	Pitch dia.	Outside dia.	Face width	Hub width (right)	Hub width (left)
						LH7(H8)	M	N	O	P	Q	Q'
SW1-R1 SW1-R2	m1	1 2	3°35' 7°11'	R	W2	6 ^{H8}	—	16	18	(20)	—	—
SW1.25-R1 SW1.25-R2	m1.25	1 2	3°25' 6°50'	R	W2	8	—	21	23.5	(25)	—	—

Total length	Socket head screw		Weight (kg)	Catalog Number
R	Size	S		
32	M4	5	0.043	SW1-R1 SW1-R2
37	M5	5	0.085	SW1.25-R1 SW1.25-R2

BG/CG Module 1, 1.25
Worm Wheels



Specifications	
Catalog Number	BG CG
Precision grade	KHK W 002 grade 4*
Reference section of gear	Normal plane
Gear teeth	Standard full depth
Normal pressure angle	20°
Material	CAC502 (old JIS PBC2) FC200
Heat treatment	—
Tooth hardness	—

* The precision grade of J Series products is equivalent to the value shown in the table.

A _{H7}	Bore
B	Hub dia.
C	Pitch dia.
D	Throat dia.
D'	Outside dia.
E	Face width
F	Hub width
G	Total length
J	Mounting distance

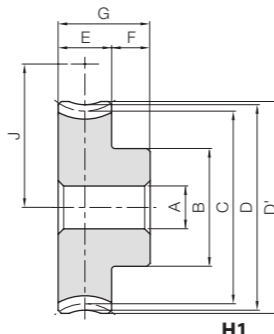

H1

Catalog Number	Reduction ratio	No. of teeth	No. of starts of mating worm	Lead angle helix direction	Shape	A _{H7}	B	C	D	D'	E	F	G	J	Allowable torque (N-m) <small>NOTE 1</small>						Backlash (mm)	Weight (kg)
															30 rpm	100 rpm	300 rpm	600 rpm	900 rpm	1200 rpm		
BG1-20R1	20	20	1	3°35'	R	H1	6	16	20.05	22	23			18	1.89	1.58	1.26	1.04	0.92	0.85	0.06~0.24	0.043
BG1-20R2	10	20	2	7°11'	R	H1	6	16	20.16	22	23			18	1.90	1.54	1.18	0.97	0.85	0.78	0.06~0.24	0.043
BG1-30R1	30	30	1	3°35'	R	H1	6	20	30.07	32	33	10	10	23	4.00	3.38	2.74	2.29	2.05	1.87	0.06~0.24	0.089
BG1-30R2	15	30	2	7°11'	R	H1	6	20	30.24	32	33			23	4.03	3.35	2.62	2.14	1.91	1.74	0.06~0.24	0.089
BG1-40R1	40	40	1	3°35'	R	H1	8	26	40.08	42	43			28	6.85	5.79	4.76	4.03	3.61	3.31	0.06~0.24	0.15
BG1-50R1	50	50	1	3°35'	R	H1	8	30	50.10	52	53			33	10.3	8.76	7.27	6.18	5.58	5.14	0.06~0.24	0.23
BG1.25-20R1	20	20	1	3°25'	R	H1	6	20	25.04	27.5	28.75			23	3.19	2.65	2.10	1.72	1.53	1.40	0.08~0.26	0.070
BG1.25-20R2	10	20	2	6°50'	R	H1	6	20	25.18	27.5	28.75	11	9	23	3.19	2.58	1.96	1.60	1.40	1.27	0.08~0.26	0.070
BG1.25-50R1	50	50	1	3°25'	R	H1	8	40	62.61	65	66.25			41.75	17.4	14.7	12.1	10.3	9.25	8.49	0.08~0.26	0.40
CG1-60R1	60	60			R	H1	10	30	60.12	62	63			38	8.69	7.39	6.14	5.24	4.78	4.39	0.06~0.24	0.25
CG1-80R1	80	80			R	H1	10	35	80.16	82	83			48	14.7	12.6	10.5	9.11	8.30	7.72	0.06~0.24	0.43
CG1-100R1	100	100			R	H1	10	40	100.20	102	103	10	10	58	21.9	19.0	16.0	13.9	12.7	11.9	0.06~0.24	0.66
CG1-120R1	120	120			R	H1	10	40	120.24	122	123			68	30.5	26.7	22.5	19.6	18.0	16.7	0.06~0.24	0.91

[Caution on Product Characteristics] ① The worm wheel is shifted to fit the mounting distance.

[NOTE 1] Allowable torque based on worm speed (rpm).

Bronze Worm Wheels & Gray Iron Worm Wheels

J Series

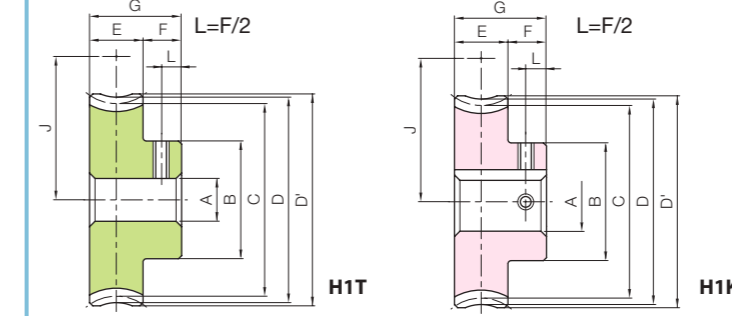

To order J Series products, please specify: **Catalog No. + J + BORE.**

Bore H7	* The product shapes of J Series items are identified by background color.											
	6	8	10	12	14	15	16	17	18	19	20	22
Keyway J _{S9}	—		4x1.8			5x2.3			6x2.8			
Screw size	—		4x1.8			5x2.3			6x2.8			
Catalog Number	M4	M5	M4			M5						
BG1-20R1 J BORE												
BG1-20R2 J BORE												
BG1-30R1 J BORE												
BG1-30R2 J BORE												
BG1-40R1 J BORE												
BG1-50R1 J BORE												
BG1.25-20R1 J BORE												
BG1.25-20R2 J BORE												
BG1.25-50R1 J BORE												
CG1-60R1 J BORE												
CG1-80R1 J BORE												
CG1-100R1 J BORE												
CG1-120R1 J BORE												

[Caution on J series] ① Cancellation is not possible for made-to-order products. See page 42 for lead times and allowable order quantities. See page 44 for other precautions.



Specifications	
Precision grade	KHK W 001 grade 4*
Reference section of gear	Normal plane
Gear teeth	Standard full depth
Normal pressure angle	20°
Material	S45C
Heat treatment	—
Tooth hardness	(less than 194HB)
Surface treatment	Black oxide coating

* The precision grade of J Series products is equivalent to the value shown in the table.

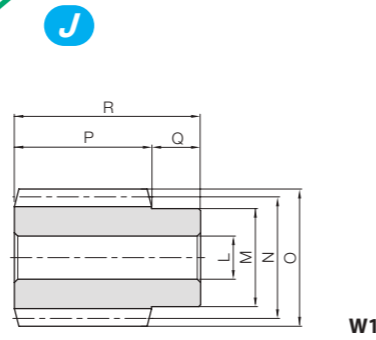

W1

J Series

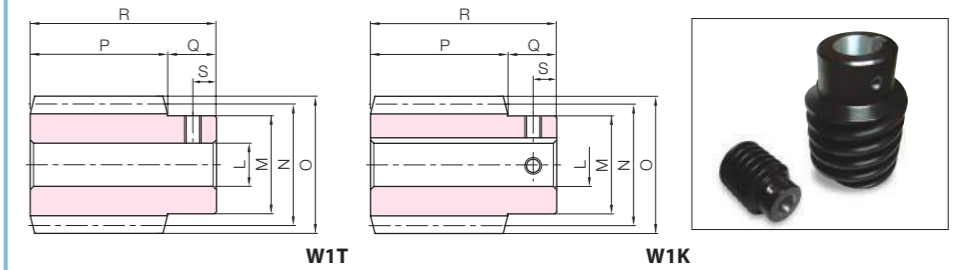

W1T

W1K

Catalog Number ● : J Series (Available-on-request)	Normal module	Number of Starts	Nominal lead angle	Direction of helix	Shape	Bore		Hub dia.	Pitch dia.	Outside dia.	Face width	Hub width (right)	Hub width (left)
						L _{H7}	M						
SW1.5-R1 ● SW1.5-R1J8 ● SW1.5-R1J10	m1.5	1	3°26'	R	W1	8	20	25	28	30	10	—	—
W1T					8								
SW1.5-R2 ● SW1.5-R2J8 ● SW1.5-R2J10	m1.5	2	6°54'	R	W1	8	20	25	28	30	10	—	—
W1T					8								
					W1K	10							

Total length R	Keyway Width × Depth	Socket head screw		Weight (kg)	Catalog Number ● : J Series (Available-on-request)
		Size	S		
40	—	—	—	0.12	SW1.5-R1
	—	M5	5	0.12	● SW1.5-R1J8
	4 x 1.8	M4	5	0.11	● SW1.5-R1J10
	—	—	—	0.12	SW1.5-R2
40	—	—	—	0.12	● SW1.5-R2J8
	—	M5	5	0.12	● SW1.5-R2J10
	4 x 1.8	M4	5	0.11	
	—	—	—	0.11	

[Caution on J series] ① Cancellation is not possible for made-to-order products. See page 42 for lead times and allowable order quantities. See page 44 for other precautions.

BG/CG Module 1.5
Worm Wheels

Bronze Worm Wheels & Gray Iron Worm Wheels

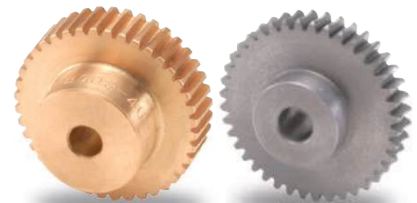

Specifications	
Catalog Number	BG CG
Precision grade	KHK W 002 grade 4*
Reference section of gear	Normal plane
Gear teeth	Standard full depth
Normal pressure angle	20°
Material	CAC502 (old JIS PBC2) FC200
Heat treatment	—
Tooth hardness	—

* The precision grade of J Series products is equivalent to the value shown in the table.

A _{H7}	Bore
B	Hub dia.
C	Pitch dia.
D	Throat dia.
D'	Outside dia.
E	Face width
F	Hub width
G	Total length
J	Mounting distance

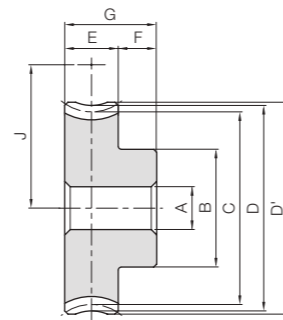

H1

J Series

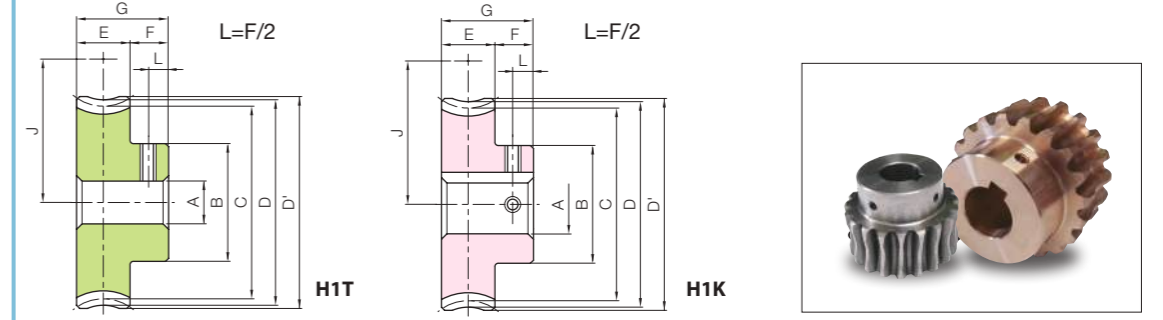

H1T

H1K

To order J Series products, please specify: **Catalog No. + J + BORE.**

Catalog Number	Reduction ratio	No. of teeth	No. of starts of mating worm	Lead angle helix direction	Shape	A _{H7}	B	C	D	D'	E	F	G	J	Allowable torque (N·m) NOTE 1							Backlash (mm)	Weight (kg)
															30 rpm	100 rpm	300 rpm	600 rpm	900 rpm	1200 rpm			
BG1.5-20R1	20	20	1	3°26'	R	H1	8	22	30.05	33	34.5	12	22	27.5	4.76	3.96	3.10	2.56	2.27	2.06	0.08~0.26	0.10	
BG1.5-20R2	10	20	2	6°54'			8	22	30.22	33	34.5	12	22	27.5	4.75	3.85	2.89	2.38	2.08	1.87			
BG1.5-30R1	30	30	1	3°26'	R	H1	10	30	45.08	48	49.5	12	22	35	10.1	8.47	6.72	5.67	5.03	4.55	0.08~0.26	0.22	
BG1.5-30R2	15	30	2	6°54'			10	30	45.33	48	49.5	12	22	35	10.1	8.37	6.40	5.26	4.67	4.20			
BG1.5-40R1	40	40	1	3°26'	R	H1	12	30	60.11	63	64.5	12	22	42.5	17.2	14.5	11.7	9.96	8.86	8.04	0.08~0.26	0.35	
BG1.5-50R1	50	50	1	3°26'			12	40	75.13	78	79.5	14	24	50	30.4	25.6	20.8	17.8	16.0	14.6			
CG1.5-30R1	30	30	1	3°26'	R	H1	10	30	45.08	48	49.5	12	22	35	6.04	5.08	4.03	3.40	3.02	2.73	0.08~0.26	0.18	
CG1.5-40R1	40	40	1	3°26'			12	30	60.11	63	64.5	12	22	42.5	10.3	8.71	7.01	5.98	5.31	4.83			
CG1.5-50R1	50	50	1	3°26'	R	H1	12	40	75.13	78	79.5	14	24	50	18.2	15.4	12.5	10.7	9.59	8.74	0.08~0.26	0.53	
CG1.5-60R1	60	60	1	3°26'			12	40	90.16	93	94.5	14	24	57.5	25.5	21.6	17.6	15.1	13.7	12.4			

[Caution on Product Characteristics] ① The worm wheel is shifted to fit the mounting distance.

[NOTE 1] Allowable torque based on worm speed (rpm).

Bore H7	* The product shapes of J Series items are identified by background color.														
	8	10	12	14	15	16	17	18	19	20	22	25	28	30	
Keyway J _{s9}	4x1.8			5x2.3			6x2.8			8x3.3					
Screw size	M5			M4			M5			M6					
Catalog Number	BG1.5-20R1 J BORE BG1.5-20R2 J BORE BG1.5-30R1 J BORE BG1.5-30R2 J BORE BG1.5-40R1 J BORE BG1.5-50R1 J BORE CG1.5-30R1 J BORE CG1.5-40R1 J BORE CG1.5-50R1 J BORE CG1.5-60R1 J BORE														

[Caution on J series] ① Cancellation is not possible for made-to-order products. See page 42 for lead times and allowable order quantities. See page 44 for other precautions.



Specifications	
Precision grade	KHK W 001 grade 4*
Reference section of gear	Normal plane
Gear teeth	Standard full depth
Normal pressure angle	14°30'
Material	S45C
Heat treatment	—
Tooth hardness	(less than 194HB)
Surface treatment	Black oxide coating

* The precision grade of J Series products is equivalent to the value shown in the table.

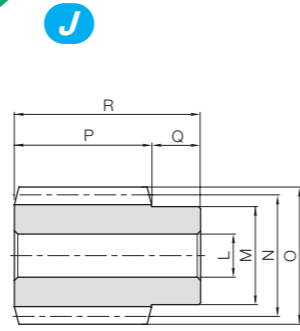

W1

J Series

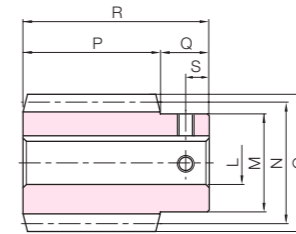

W1K



Catalog Number ● : J Series (Available-on-request)	Normal module	Number of Starts	Nominal lead angle	Direction of helix	Shape	Bore		Hub dia.	Pitch dia.	Outside dia.	Face width	Hub width (right)	Hub width (left)
						L _{H7}	M						
SW2-R1 ● SW2-R1J12 ● SW2-R1J14	m2	1	3°42'	R	W1	12	25	31	35	32	14	—	
W1K					12								
W1K					14								
SW2-R2 ● SW2-R2J12 ● SW2-R2J14		2	7°25'	R	W1	12							
W1K					12								
W1K					14								
SW2-L1 ● SW2-L1J12 ● SW2-L1J14	m2	1	3°42'	L	W1	12	25	31	35	32	14	—	
W1K					12								
W1K					14								
SW2-L2 ● SW2-L2J12 ● SW2-L2J14		2	7°25'	L	W1	12							
W1K					12								
W1K					14								

Total length R	Keyway Width × Depth	Socket head screw Size	S	Weight (kg)	Catalog Number ● : J Series (Available-on-request)	
					SW2-R1 ● SW2-R1J12 ● SW2-R1J14	SW2-R2 ● SW2-R2J12 ● SW2-R2J14
46	—	—	—	0.20	SW2-R1	SW2-L1
	4 × 1.8	M4	7	0.20	● SW2-R1J12	● SW2-L1J12
	5 × 2.3	M4	7	0.18	● SW2-R1J14	● SW2-L1J14
	—	—	—	0.20	SW2-R2	SW2-L2
	4 × 1.8	M4	7	0.20	● SW2-R2J12	● SW2-L2J12
	5 × 2.3	M4	7	0.18	● SW2-R2J14	● SW2-L2J14
	—	—	—	0.20	SW2-L1	SW2-L1
	4 × 1.8	M4	7	0.20	● SW2-L1J12	● SW2-L1J12
	5 × 2.3	M4	7	0.18	● SW2-L1J14	● SW2-L1J14
	—	—	—	0.20	SW2-L2	SW2-L2
	4 × 1.8	M4	7	0.20	● SW2-L2J12	● SW2-L2J12
	5 × 2.3	M4	7	0.18	● SW2-L2J14	● SW2-L2J14

[Caution on J series] ① Cancellation is not possible for made-to-order products. See page 42 for lead times and allowable order quantities. See page 44 for other precautions.



BG/CG Module 2
Worm Wheels



Specifications	
Catalog Number	BG CG
Precision grade	KHK W 002 grade 4*
Reference section of gear	Normal plane
Gear teeth	Standard full depth
Normal pressure angle	14°30'
Material	CAC502 (old JIS PBC2) FC200
Heat treatment	—
Tooth hardness	—

* The precision grade of J Series products is equivalent to the value shown in the table.

A _{H7}	Bore
B	Hub dia.
C	Pitch dia.
D	Throat dia.
D'	Outside dia.
E	Face width
F	Hub width
G	Total length
J	Mounting distance

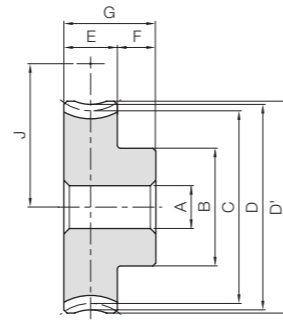

H1

J Series

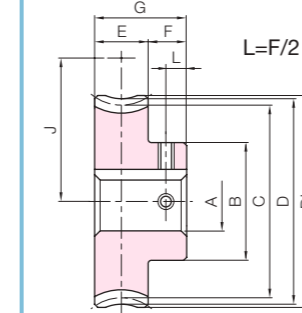

H1K

Bronze Worm Wheels & Gray Iron Worm Wheels



To order J Series products, please specify: **Catalog No. + J + BORE.**

Catalog Number	Reduction ratio	No. of teeth	No. of starts of mating worm	Lead angle helix direction	Shape	A _{H7}	B	C	D	D'	E	F	G	J	Allowable torque (N·m) <small>NOTE 1</small>						Backlash (mm)	Weight (kg)
															30 rpm	100 rpm	300 rpm	600 rpm	900 rpm	1200 rpm		
															* The product shapes of J Series items are identified by background color.							
BG2-20R1	20	20	1	3°42'	R	12	33	40.08	44	46	22	13	35	35.5	12.3	10.2	8.00	6.59	5.78	5.25	0.10~0.28	0.33
BG2-20R2	10	20	2	7°25'	H1	12	33	40.34	44	46	22	13	35	35.5	12.3	10.0	7.51	6.15	5.32	4.80		
BG2-20L1	20	20	1	3°42'	L	12	33	40.08	44	46	22	13	35	35.5	12.3	10.2	8.00	6.59	5.78	5.25	0.10~0.28	0.33
BG2-20L2	10	20	2	7°25'	H1	12	33	40.34	44	46	22	13	35	35.5	12.3	10.0	7.51	6.15	5.32	4.80		
CG2-20R1	20	20	1	3°42'	R	12	33	40.08	44	46	22	13	35	35.5	7.38	6.15	4.80	3.95	3.47	3.15	0.10~0.28	0.27
CG2-20R2	10	20	2	7°25'	H1	12	33	40.34	44	46	22	13	35	35.5	7.40	6.00	4.51	3.69	3.19	2.88		
CG2-30R1	30	30	1	3°42'	R	12	40	60.13	64	66	22	13	35	35.5	15.6	13.1	10.4	8.74	7.70	6.96	0.10~0.28	0.57
CG2-30R2	15	30	2	7°25'	H1	12	40	60.51	64	66	22	13	35	35.5	15.7	13.1	9.96	8.15	7.18	6.45		
CG2-40R1	40	40	1	3°42'	R	12	45	80.17	84	86	22	13	35	35.5	26.7	22.5	18.1	15.4	13.55	12.3	0.10~0.28	0.96
CG2-50R1	50	50	1	3°42'	H1	12	48	100.21	104	106	22	13	35	35.5	40.3	34.1	27.6	23.6	21.0	19.1		
CG2-50R2	25	50	2	7°25'	H1	12	48	100.84	104	106	22	13	35	35.5	40.7	34.0	26.9	22.4	19.6	17.8	0.10~0.28	1.44
CG2-60R1	60	60	1	3°42'	H1	12	60	120.25	124	126	22	13	35	35.5	56.4	47.9	38.9	33.3	29.9	27.2		
CG2-20L1	20	20	1	3°42'	L	12	33	40.08	44	46	22	13	35	35.5	7.38	6.15	4.80	3.95	3.47	3.15	0.10~0.28	0.27
CG2-20L2	10	20	2	7°25'	H1	12	33	40.34	44	46	22	13	35	35.5	7.40	6.00	4.51	3.69	3.19	2.88		
CG2-30L1	30	30	1	3°42'	L	12	40	60.13	64	66	22	13	35	35.5	15.6	13.1	10.4	8.74	7.70	6.96	0.10~0.28	0.57
CG2-40L1	40	40	1	3°42'	H1	12	45	80.17	84	86	22	13	35	35.5	26.7	22.5	18.1	15.4	13.55	12.3		
CG2-50L1	50	50	1	3°42'	H1	12	48	100.21	104	106	22	13	35	35.5	40.3	34.1	27.6	23.6	21.0	19.1	0.10~0.28	1.44
CG2-60L1	60	60	1	3°42'	H1	12	60	120.25	124	126	22	13	35	35.5	56.4	47.9	38.9	33.3	29.9	27.2		

[Caution on Product Characteristics] ① The worm wheel is shifted to fit the mounting distance.

[NOTE 1] Allowable torque based on worm speed (rpm).

[Caution on J series] ① Cancellation is not possible for made-to-order products. See page 42 for lead times and allowable order quantities. See page 44 for other precautions.



Specifications	
Precision grade	KHK W 001 grade 4*
Reference section of gear	Normal plane
Gear teeth	Standard full depth
Normal pressure angle	20°
Material	S45C
Heat treatment	—
Tooth hardness	(less than 194HB)
Surface treatment	Black oxide coating

* The precision grade of J Series products is equivalent to the value shown in the table.

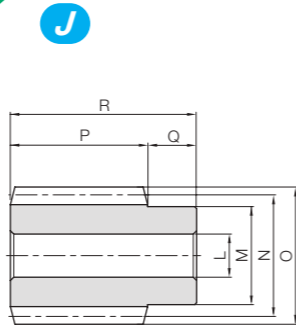

W1

J Series

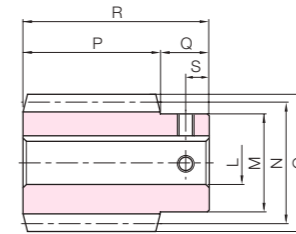

W1K



Catalog Number ● : J Series (Available-on-request)	Normal module	Number of Starts	Nominal lead angle	Direction of helix	Shape	Bore		Hub dia.	Pitch dia.	Outside dia.	Face width	Hub width (right)		Hub width (left)	
						L _{H7}	M					N	O	P	Q
SW2.5-R1 ● SW2.5-R1J15 ● SW2.5-R1J16 ● SW2.5-R1J17	m2.5	1	3°52'	R	W1	15	30	37	42	45	18	—	—	—	—
W1K					15										
W1K					16										
W1K					17										
SW2.5-R2 ● SW2.5-R2J15 ● SW2.5-R2J16 ● SW2.5-R2J17		2	7°46'	R	W1	15									
W1K					15										
W1K					16										
W1K					17										
SW2.5-L1 ● SW2.5-L1J15 ● SW2.5-L1J16 ● SW2.5-L1J17	1	3°52'	L	W1	15										
W1K				15											
W1K				16											
W1K				17											
SW2.5-L2 ● SW2.5-L2J15 ● SW2.5-L2J16 ● SW2.5-L2J17	2	7°46'	L	W1	15										
W1K				15											
W1K				16											
W1K				17											

Total length R	Keyway Width × Depth	Socket head screw Size	S	Weight (kg)	Catalog Number ● : J Series (Available-on-request)	
					● SW2.5-R1 ● SW2.5-R1J15 ● SW2.5-R1J16 ● SW2.5-R1J17	● SW2.5-R2 ● SW2.5-R2J15 ● SW2.5-R2J16 ● SW2.5-R2J17
63	—	—	—	0.39	● SW2.5-L1 ● SW2.5-L1J15 ● SW2.5-L1J16 ● SW2.5-L1J17	● SW2.5-L2 ● SW2.5-L2J15 ● SW2.5-L2J16 ● SW2.5-L2J17
	5 × 2.3	M4	9	0.39		
	5 × 2.3	M4	9	0.37		
	5 × 2.3	M4	9	0.36		
	—	—	—	0.39		
	5 × 2.3	M4	9	0.39		
	5 × 2.3	M4	9	0.37		
	5 × 2.3	M4	9	0.36		
	—	—	—	0.39		
	5 × 2.3	M4	9	0.39		
	5 × 2.3	M4	9	0.37		
	5 × 2.3	M4	9	0.36		

[Caution on J series] ① Cancellation is not possible for made-to-order products. See page 42 for lead times and allowable order quantities. See page 44 for other precautions.



BG/CG Module 2.5
Worm Wheels

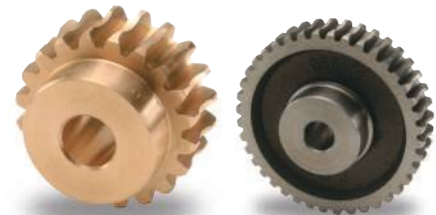

Specifications	
Catalog Number	BG CG
Precision grade	KHK W 002 grade 4*
Reference section of gear	Normal plane
Gear teeth	Standard full depth
Normal pressure angle	20°
Material	CAC502 (old JIS PBC2) FC200
Heat treatment	—
Tooth hardness	—

* The precision grade of J Series products is equivalent to the value shown in the table.

A _{H7}	Bore
B	Hub dia.
C	Pitch dia.
D	Throat dia.
D'	Outside dia.
E	Face width
F	Hub width
G	Total length
(H)	Web thickness
(I)	Web O.D.
J	Mounting distance

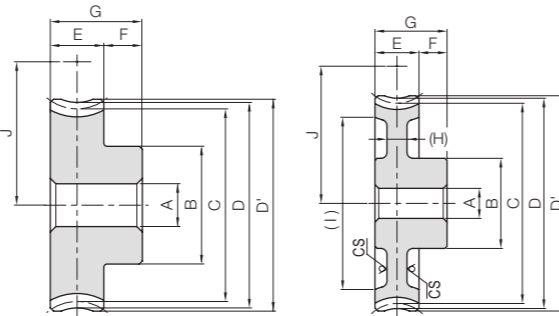

H1

HB

** CS has a forged finish surface.

Catalog Number	Reduction ratio	No. of teeth	No. of starts of mating worm	Lead angle helix direction	Shape	A _{H7}	B	C	D	D'	E	F	G	(H)	(I)	J	Allowable torque (N·m) NOTE 1						Backlash (mm)	Weight (kg)	
																	30 rpm	100 rpm	300 rpm	600 rpm	900 rpm	1200 rpm			
																	30 rpm	100 rpm	300 rpm	600 rpm	900 rpm	1200 rpm			
BG2.5-20R1	20	10	1	3°52'	R	12	35	50.11	55	57.5	22	14	36	—	—	43.5	21.5	17.7	13.8	11.4	9.94	9.07	0.13~0.31	0.49	
BG2.5-20R2	20	20	2	7°46'	H1	12	35	50.46	55	57.5	22	14	36	—	—	43.5	21.5	17.7	13.8	11.4	9.94	9.07			
BG2.5-20L1	20	10	1	3°52'	L	12	40	75.17	80	82.5	—	—	—	—	—	—	21.5	17.7	13.8	11.4	9.94	9.07	0.13~0.31	1.39	
BG2.5-20L2	20	20	2	7°46'	H1	12	40	75.17	80	82.5	—	—	—	—	—	—	21.5	17.7	13.8	11.4	9.94	9.07			
CG2.5-20R1	20	20	2	7°46'	H1	12	35	50.46	55	57.5	—	—	—	—	—	—	56	27.3	22.8	18.0	15.1	13.2	12.0	0.13~0.31	1.54
CG2.5-20R2	20	20	2	7°46'	H1	12	35	50.46	55	57.5	—	—	—	—	—	—	56	27.3	22.8	18.0	15.1	13.2	12.0		
CG2.5-30R1	30	30	1	3°52'	R	15	45	100.23	105	107.5	—	—	—	—	—	—	68.5	46.7	39.0	31.3	26.5	23.3	21.2	0.13~0.31	1.39
CG2.5-40R1	40	40	1	3°52'	R	15	45	100.23	105	107.5	—	—	—	—	—	—	68.5	46.7	39.0	31.3	26.5	23.3	21.2		
CG2.5-50R1	50	50	1	3°52'	HB	15	50	125.29	130	132.5	22	14	36	(9)	(110)	81	70.6	59.0	47.8	40.7	36.1	33.0	33.0	0.13~0.31	1.54
CG2.5-60R1	60	60	1	3°52'	HB	15	55	150.34	155	157.5	—	—	—	—	—	—	93.5	98.8	82.9	67.3	57.6	51.5	47.0		
CG2.5-20L1	20	20	1	3°52'	L	12	35	50.11	55	57.5	—	—	—	—	—	—	43.5	12.9	10.6	8.30	6.83	5.97	5.44	0.40	0.40
CG2.5-20L2	10	20	2	7°46'	L	12	35	50.46	55	57.5	—	—	—	—	—	—	43.5	12.9	10.4	7.78	6.36	5.49	4.96		
CG2.5-40L1	40	40	1	3°52'	L	15	45	100.23	105	107.5	—	—	—	—	—	—	68.5	46.7	39.0	31.3	26.5	23.3	21.2	0.40	1.39
CG2.5-40L2	40	40	1	3°52'	L	15	45	100.23	105	107.5	—	—	—	—	—	—	68.5	46.7	39.0	31.3	26.5	23.3	21.2		

[Caution on Product Characteristics] ① The worm wheel is shifted to fit the mounting distance.

[NOTE 1] Allowable torque based on worm speed (rpm).

J Series

Bronze Worm Wheels & Gray Iron Worm Wheels

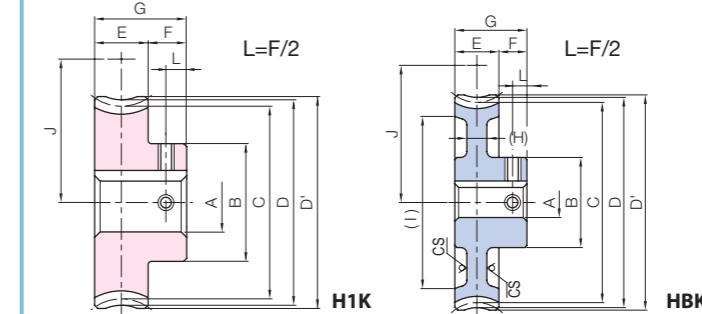

H1K

HBK



To order J Series products, please specify: **Catalog No. + J + BORE.**

Bore H7	* The product shapes of J Series items are identified by background color.																														
	12	14	15	16	17	18	19	20	22	25	28	30	32	35																	
Keyway J _{s9}	4×1.8			5×2.3				6×2.8				8×3.3		10×3.3																	
Screw size	M4			M5				M6				M8																			
Catalog Number	BG2.5-20R1 J BORE			BG2.5-20R2 J BORE				BG2.5-20L1 J BORE				BG2.5-20L2 J BORE		CG2.5-20R1 J BORE		CG2.5-20R2 J BORE		CG2.5-30R1 J BORE		CG2.5-40R1 J BORE		CG2.5-50R1 J BORE		CG2.5-60R1 J BORE		CG2.5-20L1 J BORE		CG2.5-20L2 J BORE		CG2.5-40L1 J BORE	

[Caution on J series] ① Cancellation is not possible for made-to-order products. See page 42 for lead times and allowable order quantities. See page 44 for other precautions.



Specifications	
Precision grade	KHK W 001 grade 4*
Reference section of gear	Normal plane
Gear teeth	Standard full depth
Normal pressure angle	14°30'
Material	S45C
Heat treatment	—
Tooth hardness	(less than 194HB)
Surface treatment	Black oxide coating

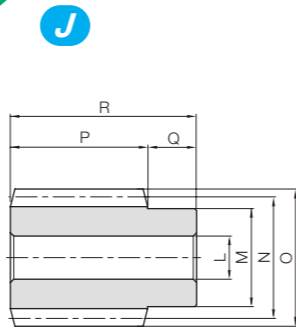

W1

* The precision grade of J Series products is equivalent to the value shown in the table.

J Series

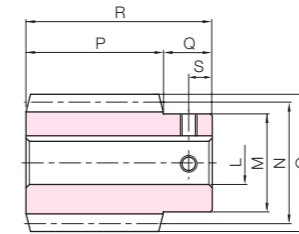

W1K



Catalog Number ● : J Series (Available-on-request)	Normal module	Number of Starts	Nominal lead angle	Direction of helix	Shape	Bore		Hub dia.	Pitch dia.	Outside dia.	Face width	Hub width (right)	Hub width (left)
						L _{H7}	M						
SW3-R1 ● SW3-R1J17 ● SW3-R1J18 ● SW3-R1J19 ● SW3-R1J20	m3	1	3°55'	R	W1	16	35	44	50	50	20	—	
W1K					17								
W1K					18								
W1K					19								
W1K		20											
SW3-R2 ● SW3-R2J17 ● SW3-R2J18 ● SW3-R2J19 ● SW3-R2J20		2	7°50'	R	W1	16							
W1K					17								
W1K					18								
W1K	19												
SW3-L1 ● SW3-L1J17 ● SW3-L1J18 ● SW3-L1J19 ● SW3-L1J20	1	3°55'	L	W1	16								
W1K				17									
W1K				18									
W1K				19									
SW3-L2 ● SW3-L2J17 ● SW3-L2J18 ● SW3-L2J19 ● SW3-L2J20	2	7°50'	L	W1	16								
W1K				17									
W1K				18									
W1K				19									

Total length R	Keyway Width × Depth	Socket head screw		Weight (kg)	Catalog Number ● : J Series (Available-on-request)
		Size	S		
70	5 × 2.3	M4	10	0.64	SW3-R1
				0.62	● SW3-R1J17
				0.60	● SW3-R1J18
				0.58	● SW3-R1J19
	6 × 2.8	M5	10	0.56	● SW3-R1J20
				0.64	SW3-R2
				0.62	● SW3-R2J17
				0.60	● SW3-R2J18
	6 × 2.8	M5	10	0.58	● SW3-R2J19
				0.56	● SW3-R2J20
				0.64	SW3-L1
				0.62	● SW3-L1J17
6 × 2.8	M5	10	0.60	● SW3-L1J18	
			0.58	● SW3-L1J19	
			0.56	● SW3-L1J20	
			0.64	SW3-L2	
6 × 2.8	M5	10	0.62	● SW3-L2J17	
			0.60	● SW3-L2J18	
			0.58	● SW3-L2J19	
			0.56	● SW3-L2J20	

[Caution on J series] ① Cancellation is not possible for made-to-order products. See page 42 for lead times and allowable order quantities. See page 44 for other precautions.



BG/CG Module 3
Worm Wheels



Specifications	
Catalog Number	BG CG
Precision grade	KHK W 002 grade 4*
Reference section of gear	Normal plane
Gear teeth	Standard full depth
Normal pressure angle	14°30'
Material	CAC502 (old JIS PBC2) FC200
Heat treatment	—
Tooth hardness	—

* The precision grade of J Series products is equivalent to the value shown in the table.

A _{H7}	Bore
B	Hub dia.
C	Pitch dia.
D	Throat dia.
D'	Outside dia.
E	Face width
F	Hub width
G	Total length
(H)	Web thickness
(I)	Web O.D.
J	Mounting distance

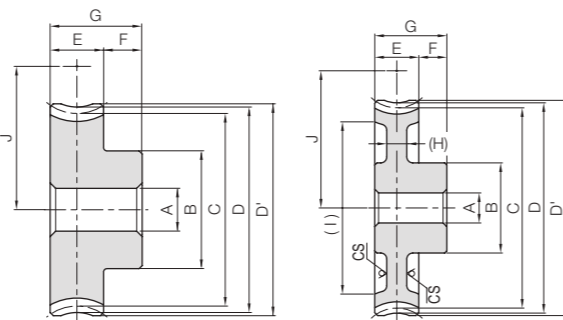

H1

HB

** CS has a forged finish surface.

J Series

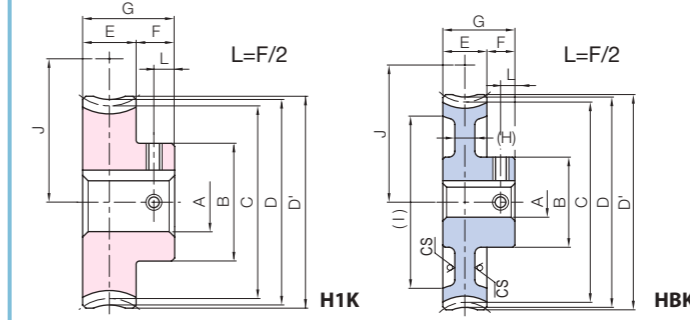

H1K

HBK



Bronze Worm Wheels & Gray Iron Worm Wheels

To order J Series products, please specify: **Catalog No. + J + BORE.**

Catalog Number	Reduction ratio	No. of teeth	No. of starts	Lead angle helix direction	Shape	A _{H7}	B	C	D	D'	E	F	G	(H)	(I)	J	Allowable torque (N·m) NOTE 1						Backlash (mm)	Weight (kg)
																	NOTE 1							
																	30 rpm	100 rpm	300 rpm	600 rpm	900 rpm	1200 rpm		
BG3-20R1 BG3-20R2	20 10	10	1 2	3°55' 7°50'	R	20	50	60.14 60.57	66	69	28	15	43	—	—	52	36.8 37.0	30.1 29.5	23.5 22.1	19.1 17.9	16.7 15.4	15.2 14.0	0.15~0.33	0.89
BG3-20L1 BG3-20L2	20 10	10	1 2	3°55' 7°50'	L	20	50	60.14 60.57	66	69	28	15	43	—	—	52	36.8 37.0	30.1 29.5	23.5 22.1	19.1 17.9	16.7 15.4	15.2 14.0	0.15~0.33	0.89
CG3-20R1 CG3-20R2 CG3-30R1 CG3-30R2	20 10 30 15	20 10 30 15	20 10 30 15	1 2 1 2	3°55' 7°50' 3°55' 7°50'	R	20	50 55 55	60.14 60.57 90.21 90.85	66 66 96 96	69 69 99 99	28	43	—	—	52	22.1 22.2 46.6 47.2	18.1 17.7 38.7 38.5	14.1 13.3 30.6 29.3	11.5 10.7 25.4 23.7	10.0 9.24 22.2 20.8	—	0.15~0.33	0.73 0.73 1.50 1.50
CG3-40R1 CG3-50R1 CG3-60R1	40 50 60	40 50 60	40 50 60	1 1 1	3°55' 3°55' 3°55'	HB	20	63 70	120.28 150.35 180.42	126 156 186	129 159 189	30	45	(9) (138) (166)	82 97 112	79.8 121 169	66.3 100 141	53.2 81.1 114	44.6 68.4 96.7	39.1 60.5 86.3	—	0.15~0.33	1.93 2.67 3.58	
CG3-20L1 CG3-20L2 CG3-30L1	20 10 30	20 10 30	20 10 30	1 2 1	3°55' 7°50' 3°55'	L	20	50 50 55	60.14 60.57 90.21	66 66 96	69 69 99	28	43	—	—	52	22.1 22.2 46.6	18.1 17.7 38.7	14.1 13.3 30.6	11.5 10.7 25.4	10.0 9.24 22.2	—	0.15~0.33	0.73 0.73 1.50
CG3-60L1	60	60	60	1	3°55'	HB	20	70	180.42	186	189	30	45	(9) (166)	112	169	141	114	96.7	86.3	—	0.15~0.33	3.58	

[Caution on Product Characteristics] ① The worm wheel is shifted to fit the mounting distance.

[NOTE 1] Allowable torque based on worm speed (rpm).

Bore H7	* The product shapes of J Series items are identified by background color.							
Keyway JS9	20	22	25	28	30	32	35	40
Screw size	6×2.8			8×3.3			10×3.3	
Catalog Number	M5			M6			M8	
BG3-20R1 J BORE								
BG3-20R2 J BORE								
BG3-20L1 J BORE								
BG3-20L2 J BORE								
CG3-20R1 J BORE								
CG3-20R2 J BORE								
CG3-30R1 J BORE								
CG3-30R2 J BORE								
CG3-40R1 J BORE								
CG3-50R1 J BORE								
CG3-60R1 J BORE								
CG3-20L1 J BORE								
CG3-20L2 J BORE								
CG3-30L1 J BORE								
CG3-60L1 J BORE								

[Caution on J series] ① Cancellation is not possible for made-to-order products. See page 42 for lead times and allowable order quantities. See page 44 for other precautions.



Specifications	
Precision grade	KHK W 001 grade 4
Reference section of gear	Normal plane
Gear teeth	Standard full depth
Normal pressure angle	14°30'
Material	S45C
Heat treatment	—
Tooth hardness	(less than 194HB)
Surface treatment	Black oxide coating (excludes semi-custom products)

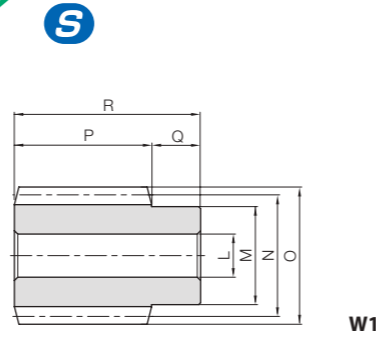

Catalog Number	Normal module	Number of Starts	Nominal lead angle	Direction of helix	Shape	Bore	Hub dia.	Pitch dia.	Outside dia.	Face width	Hub width (right)	Hub width (left)
						L _{H7}	M	N	O	P	Q	Q'
SW4-R1 SW4-R2	m4	1 2	3°42' 7°25'	R	W1	22	50	62	70	70	25	—
SW4-L1S SW4-L2S	m4	1 2	3°42' 7°25'	L	W1	22	50	62	70	70	25	—

Total length	Weight (kg)	Catalog Number
R		
95	1.76	SW4-R1 SW4-R2
95	1.76	SW4-L1S SW4-L2S

[Caution on Product Characteristics] ① Products with S at the end of the catalog number are semi-custom stock products. See page 42 for lead times and allowable order quantities. See page 44 for other precautions.

BG/CG Module 4
Worm Wheels **NEW**

Bronze Worm Wheels & Gray Iron Worm Wheels



Specifications	
Catalog Number	BG CG
Precision grade	KHK W 002 grade 4 KHK W 002 grade 4
Reference section of gear	Normal plane Normal plane
Gear teeth	Standard full depth Standard full depth
Normal pressure angle	14°30' 14°30'
Material	CAC502 (old JIS PBC2) FC200
Heat Treatment	— —
Tooth hardness	— —

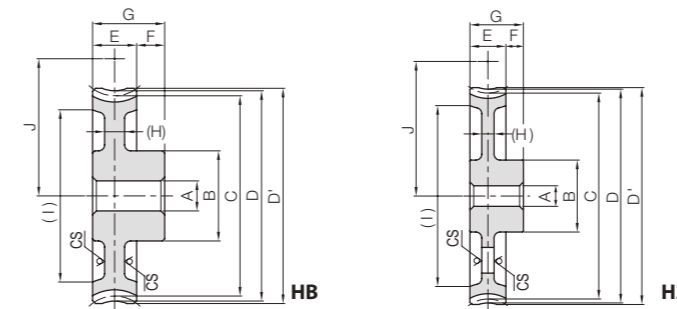
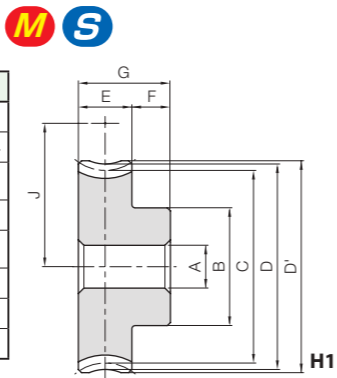

Catalog Number	Reduction ratio	Normal module	No. of teeth	No. of starts of mating worm	Lead angle	Direction of helix	Shape	Bore	Hub dia.	Pitch dia.	Throat dia.	Outside dia.	Face width
								A _{H7}	B	C	D	D'	E
BG4-20R1 BG4-20R2	20 10	m4	20	1 2	3°42' 7°25'	R	H1	20	60	80.17 80.67	88	90	35

Hub width	Total length	Mounting distance	Allowable torque (N·m) <small>NOTE 1</small>						Backlash (mm)	Weight (kg)	Catalog Number
			30 _{rpm}	100 _{rpm}	300 _{rpm}	600 _{rpm}	900 _{rpm}	1200 _{rpm}			
F	G	J	30 _{rpm}	100 _{rpm}	300 _{rpm}	600 _{rpm}	900 _{rpm}	1200 _{rpm}			
17	52	71	75.9 75.9	61.7 60.0	47.9 44.8	38.4 35.7	33.7 30.9	30.1 27.5	0.17~0.37	1.91	BG4-20R1 BG4-20R2

Catalog Number	Reduction ratio	Normal module	No. of teeth	No. of starts of mating worm	Lead angle	Direction of helix	Shape	Bore	Hub dia.	Pitch dia.	Throat dia.	Outside dia.	Face width
								A _{H7}	B	C	D	D'	E
CG4-20R1	20	m4	20	1	3°42'	R	H1	20	60	80.17	88	90	35
CG4-20R2	10		20	2	7°25'			60	80.67	88	90		
CG4-30R1	30		30	1	3°42'			60	120.25	128	130		
CG4-30R2 (Made to Order)	15	m4	30	2	7°25'	R	H1	20	60	121.01	128	130	35
CG4-40R1	40	m4	40	1	3°42'	R	HB	20	70	160.33	168	171	35
CG4-50R1	50	m4	50	1	3°42'	R	H2	20	70	200.42	208	211	35
CG4-60R1	60		60	1	3°42'			80	240.5	248	251		
CG4-20L1S	20	m4	20	1	3°42'	L	H1	20	60	80.17	88	90	35
CG4-20L2S	10		20	2	7°25'				60	80.67	88	90	
CG4-30L1S	30		30	1	3°42'				60	120.25	128	130	
CG4-40L1S	40		40	1	3°42'				70	160.33	168	171	
CG4-50L1S	50		50	1	3°42'				70	200.42	208	211	
CG4-60L1S	60		60	1	3°42'				80	240.5	248	251	

Hub width	Total length	Web thickness	Web O.D.	Mounting distance	Allowable torque (N·m) <small>NOTE 1</small>				Backlash (mm)	Weight (kg)	Catalog Number
					30 _{rpm}	100 _{rpm}	300 _{rpm}	600 _{rpm}			
F	G	(H)	(I)	J	30 _{rpm}	100 _{rpm}	300 _{rpm}	600 _{rpm}			
17	52	—	—	71	45.6	37.0	28.7	23.0	0.17~0.37	1.56	CG4-20R1
				71	45.5	36.0	26.9	21.4		1.56	CG4-20R2
				91	96.3	79.1	62.3	50.9		3.17	CG4-30R1
17	52	—	—	91	96.8	78.3	59.4	47.3	0.17~0.37	3.17	CG4-30R2 (Made to Order)
17	52	(11)	(136)	111	165	136	108	89.4	0.17~0.37	4.02	CG4-40R1
17	52	(12)	(176)	131	249	205	165	137	0.17~0.37	4.97	CG4-50R1
				151	348	288	233	194		6.58	CG4-60R1
17	52	—	—	71	45.6	37.0	28.7	23.0	0.17~0.37	12.1	CG4-20L1S
				71	45.5	36.0	26.9	21.4			CG4-20L2S
				91	96.3	79.1	62.3	50.9			CG4-30L1S
				111	165	136	108	89.4			CG4-40L1S
				131	249	205	165	137			CG4-50L1S
				151	348	288	233	194			CG4-60L1S

[Caution on Product Characteristics] ① The worm wheel is shifted to fit the mounting distance.
 ② H2 has a long cast hole in the web (H) section.
 ③ Products with S at the end of the catalog number are semi-custom stock products. See page 42 for lead times and allowable order quantities. See page 44 for other precautions.

[NOTE 1] Allowable torque based on worm speed (rpm).

[Precautions for Made to Order Products] ① Prices and lead times for Made to Order products require separate estimates. Contact your dealer.



Specifications	
Precision grade	KHK W 001 grade 4
Reference section of gear	Normal plane
Gear teeth	Standard full depth
Normal pressure angle	14°30'
Material	S45C
Heat treatment	—
Tooth hardness	(less than 194HB)
Surface treatment	Black oxide coating (excludes semi-custom products)

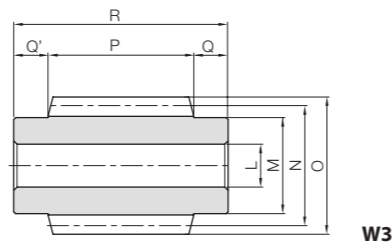

Catalog Number	Normal module	Number of Starts	Nominal lead angle	Direction of helix	Shape	Bore		Pitch dia.	Outside dia.	Face width	Hub width (right)		Hub width (left)	
						L _{H7}	M				N	O	P	Q
SW5-R1	m5	1	4°06'	R	W3	25	56	70	80	85	20	20	20	20
SW5-R2 (Made to Order)	m5	2	8°13'	R	W3	25	56	70	80	85	20	20	20	20
SW5-L1S	m5	1	4°06'	L	W3	25	56	70	80	85	20	20	20	20

Total length	Weight (kg)	Catalog Number
R		
125	2.86	SW5-R1
125	2.86	SW5-R2 (Made to Order)
125	2.86	SW5-L1S

[Caution on Product Characteristics] ① Products with S at the end of the catalog number are semi-custom stock products. See page 42 for lead times and allowable order quantities. See page 44 for other precautions.

[Precautions for Made to Order Products] ① Prices and lead times for Made to Order products require separate estimates. Contact your dealer.

BG/CG Module 5
Worm Wheels **NEW**



Specifications	
Catalog Number	BG CG
Precision grade	KHK W 002 grade 4 KHK W 002 grade 4
Reference section of gear	Normal plane Normal plane
Gear teeth	Standard full depth Standard full depth
Normal pressure angle	14°30' 14°30'
Material	CAC502 (old JIS PBC2) FC200
Heat Treatment	— —
Tooth hardness	— —

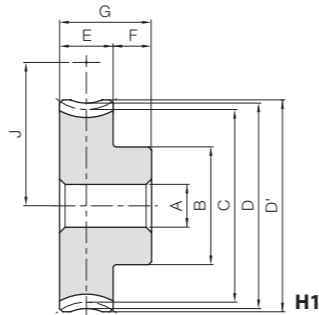

Catalog Number	Reduction ratio	Normal module	No. of teeth	No. of starts of mating worm	Lead angle	Direction of helix	Shape	Bore		Pitch dia.	Throat dia.	Outside dia.	Face width
								A _{H7}	B				
BG5-20R1	20	m5	20	1	4°06'	R	H1	22	75	100.26	110	113	45
BG5-20R2 (Made to Order)	10	m5	20	2	8°13'	R	H1	22	75	101.04	110	113	45

Catalog Number	Reduction ratio	Normal module	No. of teeth	No. of starts of mating worm	Lead angle	Direction of helix	Shape	Bore		Pitch dia.	Throat dia.	Outside dia.	Face width
								A _{H7}	B				
CG5-20R1	20	m5	20	1	4°06'	R	H1	22	75	100.26	110	113	45
CG5-30R1	30		30	1	4°06'	R	HB	22	75	150.38	160	163	45
CG5-30R2 (Made to Order)	15	m5	30	2	8°13'	R	HB	22	75	151.56	160	163	45
CG5-40R1	40	m5	40	1	4°06'	R	H2	22	90	200.51	210	213	45
CG5-50R1	50	m5	50	1	4°06'	R	H2	22	90	250.61	260	263	45
CG5-60R1	60		60					300.77	310	313			
CG5-20L1S	20	m5	20	1	4°06'	L	H1	22	75	100.26	110	113	45
CG5-30L1S	30		30					150.38	160	163			
CG5-40L1S	40		40					200.51	210	213			
CG5-50L1S	50		50					250.64	260	263			
CG5-60L1S	60		60					300.77	310	313			

- [Caution on Product Characteristics] ① The worm wheel is shifted to fit the mounting distance.
 ② H2 has a long cast hole in the web (H) section.
 ③ Products with S at the end of the catalog number are semi-custom stock products. See page 42 for lead times and allowable order quantities. See page 44 for other precautions.
 ④ For S semi-custom standard products weighing 15 kg or more, eyebolt screw threads (2-M12 depth 25 mm) are machined around the outside of the hub side surface. Details of the PCD of the screw threads are located on page 51.

[Precautions for Made to Order Products] ① Prices and lead times for Made to Order products require separate estimates. Contact your dealer.

Bronze Worm Wheels & Gray Iron Worm Wheels

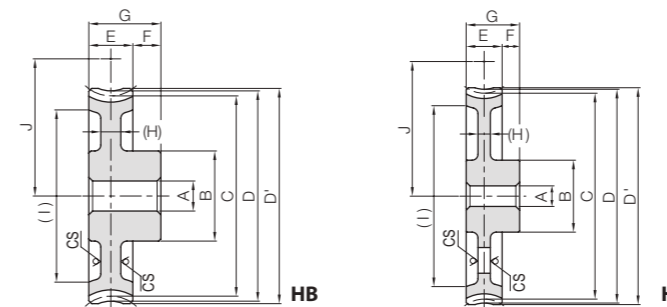

* CS has a forged finish surface.



Hub width	Total length	Mounting distance	Allowable torque (N·m) ^{NOTE 1}						Backlash (mm)	Weight (kg)	Catalog Number
			30 _{rpm}	100 _{rpm}	300 _{rpm}	600 _{rpm}	900 _{rpm}	1200 _{rpm}			
F	G	J	30 _{rpm}	100 _{rpm}	300 _{rpm}	600 _{rpm}	900 _{rpm}	1200 _{rpm}			
20	65	85	146	117	91.2	73.0	63.7	56.9	0.20~0.40	3.89	BG5-20R1
20	65	85	146	115	85.8	68.4	58.8	52.2	0.20~0.40	3.89	BG5-20R2 (Made to Order)

Hub width	Total length	Web thickness	Web O.D.	Mounting distance	Allowable torque (N·m) ^{NOTE 1}				Backlash (mm)	Weight (kg)	Catalog Number
					30 _{rpm}	100 _{rpm}	300 _{rpm}	600 _{rpm}			
F	G	(H)	(I)	J	30 _{rpm}	100 _{rpm}	300 _{rpm}	600 _{rpm}			
20	65	—	—	85	87.4	70.3	54.7	43.8	0.20~0.40	3.18	CG5-20R1
		(13)	(127)	110	185	150	119	96.8		5.07	CG5-30R1
20	65	(13)	(127)	110	187	150	114	90.6	0.20~0.40	5.07	CG5-30R2 (Made to Order)
20	65	(16)	(172)	135	316	258	206	170	0.20~0.40	7.75	CG5-40R1
20	65	(16)	(223)	160	477	390	315	261	10.1	10.1	CG5-50R1
		(14)	(276)	185	668	548	443	369	0.20~0.40	12.3	CG5-60R1
20	65	—	—	85	87.4	70.3	54.7	43.8		3.18	CG5-20L1S
				110	185	150	119	96.8		6.44	CG5-30L1S
				135	316	258	206	170	0.20~0.40	11.3	CG5-40L1S
				160	477	390	315	261		17.1	CG5-50L1S
				185	668	548	443	369		24.4	CG5-60L1S

[NOTE 1] Allowable torque based on worm speed (rpm).



Specifications	
Precision grade	KHK W 001 grade 4
Reference section of gear	Normal plane
Gear teeth	Standard full depth
Normal pressure angle	14°30'
Material	S45C
Heat treatment	—
Tooth hardness	(less than 194HB)
Surface treatment	Black oxide coating (excludes semi-custom products)

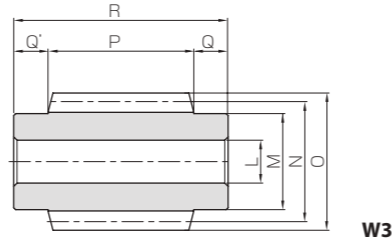

Catalog Number	Normal module	Number of Starts	Nominal lead angle	Direction of helix	Shape	Bore		Pitch dia.	Outside dia.	Face width	Hub width (right)		Hub width (left)
						L _{H7}	M				N	O	
SW6-R1	m6	1	4°18'	R	W3	30	64	80	92	100	25	25	
SW6-R2 (Made to Order)	m6	2	8°38'	R	W3	30	64	80	92	100	25	25	
SW6-L1S	m6	1	4°18'	L	W3	30	64	80	92	100	25	25	

Total length	Weight (kg)	Catalog Number
R		
150	4.38	SW6-R1
150	4.38	SW6-R2 (Made to Order)
150	4.38	SW6-L1S

[Caution on Product Characteristics] ① Products with S at the end of the catalog number are semi-custom stock products. See page 42 for lead times and allowable order quantities. See page 44 for other precautions.

[Precautions for Made to Order Products] ① Prices and lead times for Made to Order products require separate estimates. Contact your dealer.

BG · CG Module 6
Worm Wheels **NEW**



Specifications	
Catalog Number	BG CG
Precision grade	KHK W 002 grade 4 KHK W 002 grade 4
Reference section of gear	Normal plane Normal plane
Gear teeth	Standard full depth Standard full depth
Normal pressure angle	14°30' 14°30'
Material	CAC502 (old JIS PBC2) FC200
Heat Treatment	— —
Tooth hardness	— —

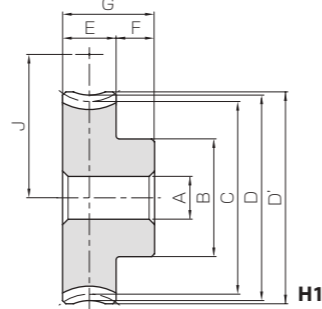

Catalog Number	Reduction ratio	Normal module	No. of teeth	No. of starts of mating worm	Lead angle	Direction of helix	Shape	Bore		Pitch dia.	Throat dia.	Outside dia.	Face width
								A _{H7}	B				
BG6-20R1	20	m6	20	1	4°18'	R	H1	25	100	120.34	132	136	52
BG6-20R2 (Made to Order)	10	m6	20	2	8°38'	R	H1	25	100	121.38	132	136	52

Catalog Number	Reduction ratio	Normal module	No. of teeth	No. of starts of mating worm	Lead angle	Direction of helix	Shape	Bore		Pitch dia.	Throat dia.	Outside dia.	Face width
								A _{H7}	B				
CG6-20R1	20	m6	20	1	4°18'	R	H1	25	100	120.34	132	136	52
CG6-30R1	30												
CG6-40R1	40												
CG6-50R1	50	m6	50	1	4°18'	H2	100	120	300.85	312	316	52	
CG6-60R1	60												
CG6-20L1S	20	m6	20	1	4°18'	L	H1	25	100	120.34	132	136	52
CG6-30L1S	30												
CG6-40L1S	40												
CG6-50L1S	50												
CG6-60L1S	60												

[Caution on Product Characteristics] ① The worm wheel is shifted to fit the mounting distance.
 ② H2 has a long cast hole in the web (H) section.
 ③ Products with S at the end of the catalog number are semi-custom stock products. See page 42 for lead times and allowable order quantities. See page 44 for other precautions.
 ④ For S semi-custom standard products weighing 15 kg or more, eyebolt screw threads (2-M12 depth 25 mm) are machined around the outside of the hub side surface. Details of the PCD of the screw threads are located on page 51.

[Precautions for Made to Order Products] ① Prices and lead times for Made to Order products require separate estimates. Contact your dealer.

Bronze Worm Wheels & Gray Iron Worm Wheels

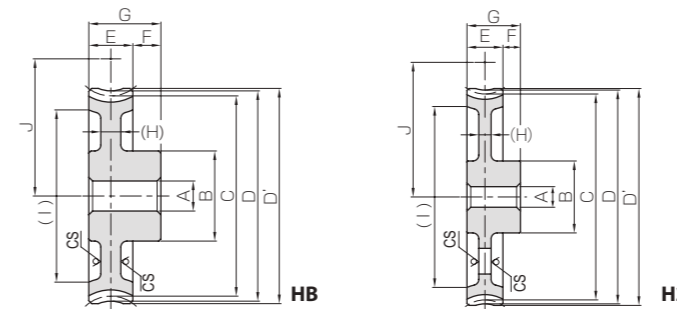

* CS has a forged finish surface.



Hub width	Total length	Mounting distance	Allowable torque (N·m) ^{NOTE 1}						Backlash (mm)	Weight (kg)	Catalog Number
			30 _{rpm}	100 _{rpm}	300 _{rpm}	600 _{rpm}	900 _{rpm}	1200 _{rpm}			
F	G	J	30 _{rpm}	100 _{rpm}	300 _{rpm}	600 _{rpm}	900 _{rpm}	1200 _{rpm}			
20	72	100	232	185	144	115	99.2	88.8	0.22~0.42	6.60	BG6-20R1
20	72	100	235	183	136	109	92.3	82.0	0.22~0.42	6.60	BG6-20R2 (Made to Order)

Hub width	Total length	Web thickness	Web O.D.	Mounting distance	Allowable torque (N·m) ^{NOTE 1}			Backlash (mm)	Weight (kg)	Catalog Number
					30 _{rpm}	100 _{rpm}	300 _{rpm}			
F	G	(H)	(I)	J	30 _{rpm}	100 _{rpm}	300 _{rpm}			
20	72	—	—	100	139	111	86.2	0.22~0.42	5.39	CG6-20R1
		(15)	(155)	130	294	237	187			
		(15)	(213)	160	502	407	325			
20	72	(16)	(275)	190	760	615	496	0.22~0.42	14.5	CG6-50R1
				220	1060	865	698			
				190	760	615	496			
				220	1060	865	698			
20	72	—	—	100	139	111	86.2	0.22~0.42	5.39	CG6-20L1S
				130	294	237	187			
				160	502	407	325			
				190	760	615	496			
				220	1060	865	698			

[NOTE 1] Allowable torque based on worm speed (rpm).



Specifications	
Precision grade	KHK W 001 grade 4
Reference section of gear	Normal plane
Gear teeth	Standard full depth
Normal pressure angle	20°
Material	S45C
Heat treatment	—
Tooth hardness	(less than 194HB)
Surface treatment	—

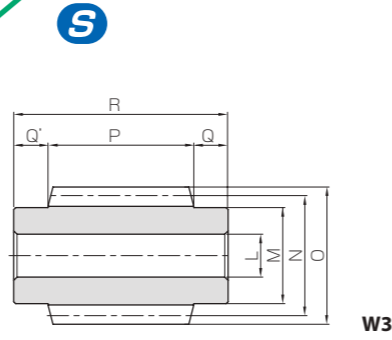

Catalog Number	Normal module	Number of Starts	Nominal lead angle	Direction of helix	Shape	Bore		Hub dia.	Pitch dia.	Outside dia.	Face width	Hub width (right)	Hub width (left)
						L _{H7}	M						
SW8-R1S	m8	1	5°6'	R	W3	30	68	90	106	120	25	5	
SW10-R1S	m10	1	5°44'	R	W3	30	73	100	120	120	25	5	

Total length	Weight (kg)	Catalog Number
R		
150	6.02	SW8-R1S
150	7.55	SW10-R1S

[Caution on Product Characteristics] ① Products with S at the end of the catalog number are semi-custom stock products. See page 42 for lead times and allowable order quantities. See page 44 for other precautions.

CG Module 8, 10
Worm Wheels **NEW**

Gray Iron Worm Wheels



Specifications	
Precision grade	KHK W 002 grade 4
Reference section of gear	Normal plane
Gear teeth	Standard full depth
Normal pressure angle	20°
Material	FC200
Heat treatment	—
Tooth hardness	—
Surface treatment	—

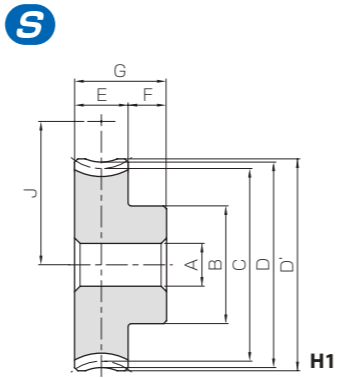

Catalog Number	Reduction ratio	Normal module	No. of teeth	No. of starts of mating worm	Lead angle	Direction of helix	Shape	Bore		Hub dia.	Pitch dia.	Throat dia.	Outside dia.	Face width				
								A _{H7}	B									
CG8-20R1S	20	m8	20	1	5°06'	R	H1	30	130	160.64	176	180	60					
CG8-30R1S	30		30					180	240.95					256	260			
CG8-40R1S	40		40					220								321.27	336	340
CG8-50R1S	50		50					240										
CG10-20R1S	20	m10	20	1	5°44'	R	H1	30	165	201.01	220	225	72					
CG10-30R1S	30		50					240	301.51					320	325			
CG10-40R1S	40		50					280	402.02					420	425			

Hub width	Total length	Mounting distance	Allowable torque (N·m) <small>NOTE 1</small>			Backlash (mm)	Weight (kg)	Catalog Number
			30 _{rpm}	100 _{rpm}	300 _{rpm}			
35	95	125	288	230	177	0.27~0.51	12.0	CG8-20R1S
		165	610	492	385			CG8-30R1S
		205	1040	843	669			CG8-40R1S
		245	1580	1280	1020			CG8-50R1S
40	112	150	524	417	320	0.32~0.59	22.8	CG10-20R1S
		200	1110	893	694			CG10-30R1S
		250	1900	1530	1210			CG10-40R1S

[Caution on Product Characteristics] ① The worm wheel is shifted to fit the mounting distance.
 ② Products with S at the end of the catalog number are semi-custom stock products. See page 42 for lead times and allowable order quantities. See page 44 for other precautions.
 ③ For S semi-custom standard products weighing 15 kg or more, eyebolt screw threads (2-M12 depth 25 mm) are machined around the outside of the hub side surface. Details of the PCD of the screw threads are located on page 51.

[NOTE 1] Allowable torque based on worm speed (rpm).





Specifications	
Precision grade	KHK W 001 grade 4
Reference section of gear	Normal plane
Gear teeth	Standard full depth
Normal pressure angle	20°
Material	SUS303
Heat treatment	—
Tooth hardness	(less than 187HB)

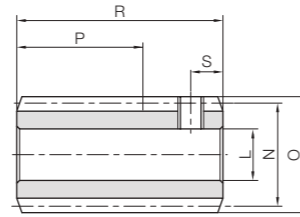

W2

Catalog Number	Normal module	Number of Starts	Nominal lead angle	Direction of helix	Shape	Bore	Hub dia.	Pitch dia.	Outside dia.	Face width	Hub width	Total length
						LH8	M	N	O	P	Q	R
SUW0.5-R1	m0.5	1	2°36'	R	W2	5	—	11	12	(10)	—	18
SUW0.5-R2		2	5°13'			—	—	—	—	—	—	—
SUW0.8-R1	m0.8	1	3°17'	R	W2	6	—	14	15.6	(18)	—	30
SUW0.8-R2		2	6°34'			—	—	—	—	—	—	—

Socket head screw		Weight (kg)	Catalog Number
Size	S		
M3	3	0.011 0.010	SUW0.5-R1 SUW0.5-R2
M4	5	0.029	SUW0.8-R1 SUW0.8-R2



Specifications	
Precision grade	KHK W 002 grade 5 *
Reference section of gear	Normal plane
Gear teeth	Standard full depth
Normal pressure angle	20°
Material	MC901
Heat treatment	—
Tooth hardness	—

* The precision grade is equivalent to the value shown in the table.

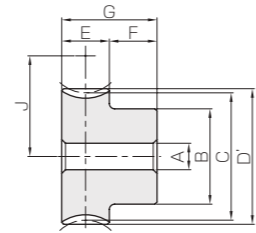

HA

Catalog Number	Normal module	Reduction ratio	No. of teeth	No. of starts of mating worm	Lead angle helix direction	Shape	A	B	C	D	D'	E	
							-0.05 -0.10						
PG0.5-20R1	m0.5	20	20	1	2°36'	R	HA	4	9	10.01	—	11	5
PG0.5-20R2		10	20	2	5°13'			4	9	10.04		11	
PG0.5-30R1		30	30	1	2°36'			4	12	15.02		16	
PG0.5-30R2		15	30	2	5°13'			4	12	15.06		16	
PG0.5-40R1		40	40	1	2°36'			5	15	20.02		21	
PG0.5-50R1	m0.5	50	50	1	2°36'	R	HA	5	20	25.03	—	26	9
PG0.5-60R1		60	60	1	2°36'			5	25	30.03		31	
PG0.8-20R1	m0.8	20	20	1	3°17'	R	HA	5	12	16.03	—	17.6	9
PG0.8-20R2		10	20	2	6°34'			5	12	16.11		17.6	
PG0.8-30R1		30	30	1	3°17'			5	18	24.04		25.6	
PG0.8-30R2		15	30	2	6°34'			5	18	24.16		25.6	
PG0.8-40R1		40	40	1	3°17'			6	20	32.05		33.6	
PG0.8-50R1	m0.8	50	50	1	3°17'	R	HA	8	25	40.07	—	41.6	9
PG0.8-60R1		60	60	1	3°17'			8	25	48.08		49.6	

(Caution on Product Characteristics) ① The worm wheel is shifted to fit the mounting distance.

F	G	J	Allowable torque (N·m)	Allowable torque (kgf·m)	Backlash (mm)	Weight (kg)	Catalog Number
			Bending strength	Bending strength			
7	12	10.5	0.077	0.0078	0.09~0.17	0.83	PG0.5-20R1
		10.5	0.077	0.0078		0.83	PG0.5-20R2
		13	0.13	0.013		1.82	PG0.5-30R1
		13	0.13	0.013		1.82	PG0.5-30R2
		15.5	0.19	0.019		3.06	PG0.5-40R1
9	18	18	0.24	0.025	0.13~0.23	5.24	PG0.5-50R1
		20.5	0.31	0.031		7.96	PG0.5-60R1
		15	0.35	0.036		3.06	PG0.8-20R1
		15	0.36	0.036		3.06	PG0.8-20R2
9	18	19	0.59	0.060	0.13~0.23	7.27	PG0.8-30R1
		19	0.60	0.061		7.27	PG0.8-30R2
		23	0.86	0.087		11.51	PG0.8-40R1
		27	1.13	0.12		17.76	PG0.8-50R1
		31	1.41	0.14		23.67	PG0.8-60R1



Specifications	
Precision grade	KHK W 001 grade 4*
Reference section of gear	Normal plane
Gear teeth	Standard full depth
Normal pressure angle	20°
Material	SUS303
Heat treatment	—
Tooth hardness	(less than 187HB)

* The precision grade of J Series products is equivalent to the value shown in the table.

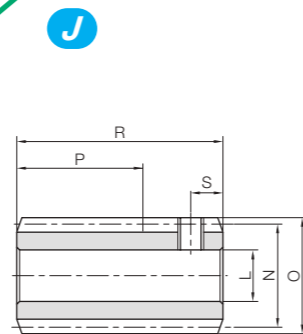

W2

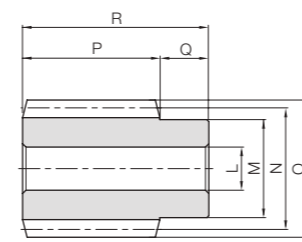

W1

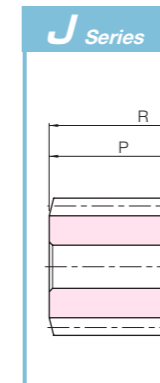

W1T

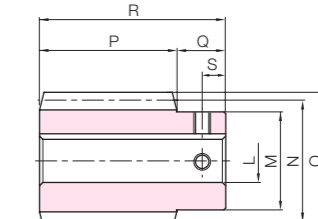

W1K



Catalog Number ● : J Series (Available-on-request)	Normal module	Number of Starts	Nominal lead angle	Direction of helix	Shape	Bore	Hub dia.	Pitch dia.	Outside dia.	Face width	Hub width	Total length
						L _{H7(H8)}						
SUW1-R1 SUW1-R2	m1	1 2	3°35' 7°11'	R	W2 W2	6 ^{H8}	—	16	18	(20)	—	32
SUW1.5-R1 ● SUW1.5-R1J8 ● SUW1.5-R1J10	m1.5	1	3°26'	R	W1 W1T W1K	8	20	25	28	30	10	40
SUW1.5-R2 ● SUW1.5-R2J8 ● SUW1.5-R2J10		2	6°54'		W1 W1T W1K	8						

[Caution on J series] ① Cancellation is not possible for made-to-order products. See page 42 for lead times and allowable order quantities. See page 44 for other precautions.

Keyway Width x Depth	Socket head screw Size	S	Weight (kg)	Catalog Number ● : J Series (Available-on-request)	
				Worm	Pinion
—	M4	5	0.043	SUW1-R1 SUW1-R2	
—	—	—	0.13	SUW1.5-R1	
—	M5	5	0.13	● SUW1.5-R1J8	
4 x 1.8	M4	5	0.11	● SUW1.5-R1J10	
—	—	—	0.13	SUW1.5-R2	
—	M5	5	0.13	● SUW1.5-R2J8	
4 x 1.8	M4	5	0.11	● SUW1.5-R2J10	



PG Module 1, 1.5
Worm Wheels



Specifications	
Precision grade	KHK W 002 grade 5*
Reference section of gear	Normal plane
Gear teeth	Standard full depth
Normal pressure angle	20°
Material	MC901
Heat treatment	—
Tooth hardness	—

* The precision grade is equivalent to the value shown in the table.

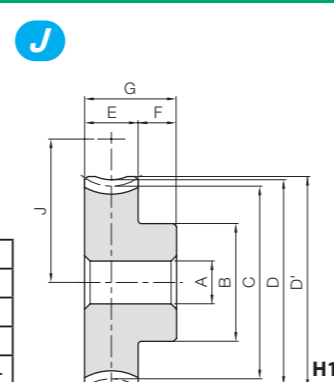

A	Bore
B	Hub dia.
C	Pitch dia.
D	Throat dia.
D'	Outside dia.
E	Face width
F	Hub width
G	Total length
J	Mounting distance

Catalog Number	Reduction ratio	No. of teeth	No. of starts of mating worm	Lead angle helix direction	Shape	A _{H8}	B	C	D	D'	E	F	G	J	Allowable torque (N·m) Bending strength	Allowable torque (kgf·m) Bending strength	Backlash (mm)	Weight (kg)	
																			H1
PG1-20R1	20	20	1	3°35'	R	6	16	20.04	22	23					18	0.62	0.060	0~0.28	0.0058
PG1-20R2	10	20	2	7°11'		6	16	20.16	22	23					18	0.62	0.060	0~0.28	0.0058
PG1-30R1	30	30	1	3°35'	R	6	20	30.06	32	33	10	10	20	23	1.03	0.10	0~0.28	0.012	
PG1-40R1	40	40	1	3°35'		8	26	40.08	42	43				28	1.49	0.15	0~0.28	0.021	
PG1-50R1	50	50	1	3°35'		8	30	50.1	52	53				33	1.96	0.20	0~0.28	0.031	
PG1.5-20R1	20	20	1	3°26'	R	8	22	30.05	33	34.5	12	10	22	27.5	1.66	0.17	0~0.30	0.014	
PG1.5-20R2	10	20	2	6°54'		8	22	30.22	33	34.5	12	10	22	27.5	1.68	0.17	0~0.30	0.014	

[Caution on Product Characteristics] ① The worm wheel is shifted to fit the mounting distance.

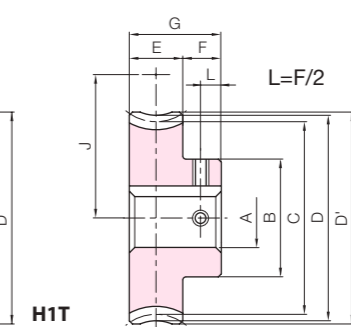
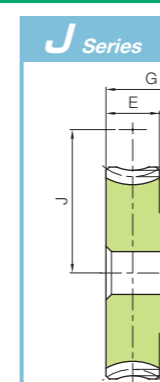

To order J Series products, please specify: **Catalog No. + J + BORE.**

Bore	* The product shapes of J Series items are identified by background color.							
	6	8	10	12	14	15	16	17
Keyway J _{S9}	—							
Screw size	—			4x1.8		5x2.3		
Catalog Number	M4	M5	M4					
PG1-20R1 J BORE								
PG1-20R2 J BORE								
PG1-30R1 J BORE								
PG1-40R1 J BORE								
PG1-50R1 J BORE								
PG1.5-20R1 J BORE								
PG1.5-20R1J BORE								
PG1.5-20R2J BORE								

[Caution on J series] ① Cancellation is not possible for made-to-order products. See page 42 for lead times and allowable order quantities. See page 44 for other precautions.

* In regard to MC Nylon gears, other materials are available for plastic gears, including Ultra High Molecular Weight Polyethylene (U-PE), which has excellent abrasion resistance Poly Ether Ether Ketone (PEEK) also has quality properties. A single piece order is acceptable and will be produced as a custom-made gear. Please see Page 26 for more details on quotations and orders.



Stainless Steel Worms



Specifications	
Precision grade	KHK W 001 grade 4*
Reference section of gear	Normal plane
Gear teeth	Standard full depth
Normal pressure angle	14°30'
Material	SUS303
Heat treatment	—
Tooth hardness	(less than 187HB)

* The precision grade of J Series products is equivalent to the value shown in the table.

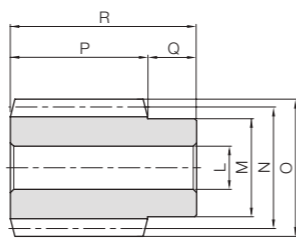

W1

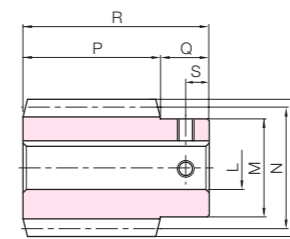

W1K



Catalog Number ● : J Series (Available-on-request)	Normal module	Number of Starts	Nominal lead angle	Direction of helix	Shape	Bore		Hub dia.	Pitch dia.	Outside dia.	Face width	Hub width	Total length	
						LH7	M							
SUW2-R1 ● SUW2-R1J12 ● SUW2-R1J14	m2	1	3°42'	R	W1	12	25	31	35	32	14	46		
						12								
						14								
SUW2-R2 ● SUW2-R2J12 ● SUW2-R2J14	m2	2	7°25'	R	W1	12	35	44	50	50	20	70		
						12								
						14								
SUW3-R1 ● SUW3-R1J17 ● SUW3-R1J18 ● SUW3-R1J19 ● SUW3-R1J20	m3	1	3°55'	R	W1	16	35	44	50	50	20	70		
						17								
						18								
		SUW3-R2 ● SUW3-R2J17 ● SUW3-R2J18 ● SUW3-R2J19 ● SUW3-R2J20	m3	2	7°50'	R	W1	16	35	44	50	50	20	70
								17						
								18						

[Caution on J series] ① Cancellation is not possible for made-to-order products. See page 42 for lead times and allowable order quantities. See page 44 for other precautions.

Keyway Width x Depth	Socket head screw Size	S	Weight (kg)	Catalog Number ● : J Series (Available-on-request)	
				W	D
—	—	—	0.20	SUW2-R1	SUW2-R1J12
4 x 1.8	M4	7	0.20	● SUW2-R1J12	● SUW2-R1J14
5 x 2.3	M4	7	0.18	● SUW2-R1J14	
—	—	—	0.20	SUW2-R2	SUW2-R2J12
4 x 1.8	M4	7	0.20	● SUW2-R2J12	● SUW2-R2J14
5 x 2.3	M4	7	0.18	● SUW2-R2J14	
—	—	—	0.64	SUW3-R1	SUW3-R1J17
5 x 2.3	M4	10	0.62	● SUW3-R1J17	● SUW3-R1J18
6 x 2.8	M5	10	0.60	● SUW3-R1J18	● SUW3-R1J19
6 x 2.8	M5	10	0.59	● SUW3-R1J19	● SUW3-R1J20
6 x 2.8	M5	10	0.57	● SUW3-R1J20	
—	—	—	0.64	SUW3-R2	SUW3-R2J17
5 x 2.3	M4	10	0.62	● SUW3-R2J17	● SUW3-R2J18
6 x 2.8	M5	10	0.60	● SUW3-R2J18	● SUW3-R2J19
6 x 2.8	M5	10	0.59	● SUW3-R2J19	● SUW3-R2J20
6 x 2.8	M5	10	0.57	● SUW3-R2J20	



Worm Wheels



Specifications	
Precision grade	KHK W 002 grade 5*
Reference section of gear	Normal plane
Gear teeth	Standard full depth
Normal pressure angle	14°30'
Material	MC901
Heat treatment	—
Tooth hardness	—

* The precision grade is equivalent to the value shown in the table.

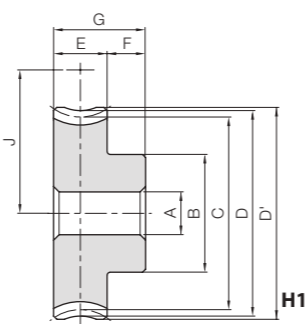

H1

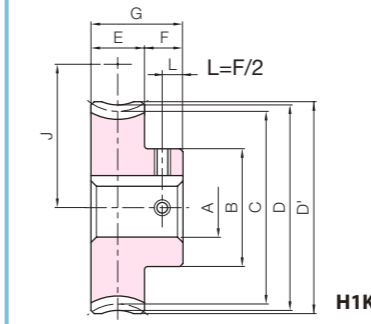

H1K

Plastic Worm Wheels



Catalog Number	Reduction ratio	No. of teeth	No. of starts of mating worm	Lead angle helix direction	Shape	A _{H8}	B	C	D	D'	E	F	G	J	Allowable torque (N·m) Bending strength	Allowable torque (kgf·m) Bending strength	Backlash (mm)	Weight (kg)
PG2-20R1	20	20	1	3°42'	R	H1	10	33	40.08	44	22	13	35	35.5	4.78	0.49	0~0.33	0.046
PG2-20R2	10	20	2	7°25'	R	H1	10	33	40.34	44	22	13	35	35.5	4.82	0.49	0~0.33	0.046
PG3-20R1	20	20	1	3°55'	R	H1	15	50	60.14	66	28	15	43	52	(13.7)	1.40	0~0.38	0.13
PG3-20R2	10	20	2	7°50'	R	H1	15	50	60.57	66	28	15	43	52	(13.8)	1.41	0~0.38	0.13

[Caution on Product Characteristics] ① The worm wheel is shifted to fit the mounting distance.

To order J Series products, please specify: **Catalog No. + J + BORE.**

Bore	* The product shapes of J Series items are identified by background color.											
	10	12	14	15	16	17	18	19	20	22	25	28
Keyway JS9	4x1.8			5x2.3			6x2.8			8x3.3		
Screw size	M4			M5			M6					
Catalog Number	PG2-20R1 J BORE			PG2-20R2 J BORE			PG3-20R1 J BORE			PG3-20R2 J BORE		

[Caution on J series] ① Cancellation is not possible for made-to-order products. See page 42 for lead times and allowable order quantities. See page 44 for other precautions.



Custom-made worm gears are available.

KHK offers high-precision products.



- ◆ Production Range
- Module : 0.5~10
- Assembly distance : 350 mm or less
- Worm outer diameter : ϕ 100 mm or less
- Total length : 600 mm or less
- Weight : 25kg or less
- Wheel outer diameter : ϕ 600 mm or less
- Weight : 200kg or less



High-precision ground gear technology achieves high speed and quiet movement.

Excellent tooth contact and appropriate backlash are essential for worm gears. Give KHK's reliable stock worm gears a try.



Custom-made Worm Grinding Machine

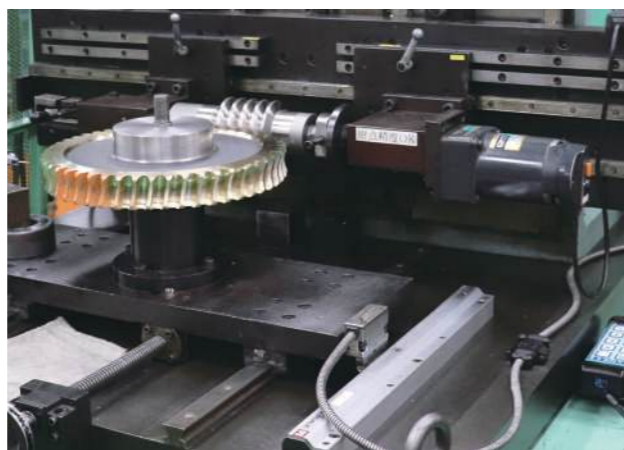

Worm Gear Tooth Contact Machine



Gearboxes

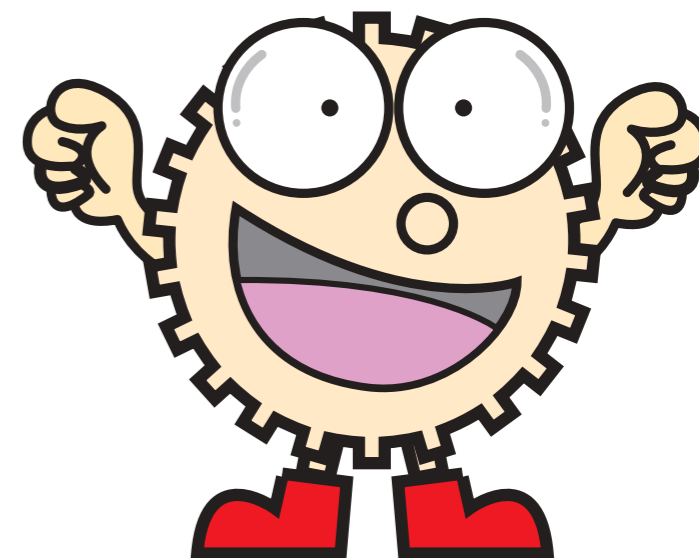
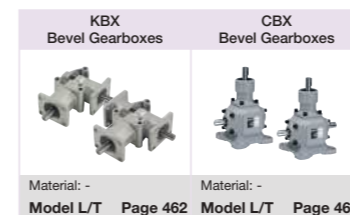

Catalog Number of KHK Stock Gears

The Catalog Number for KHK stock gears is based on the simple formula listed below. Please order KHK gears by specifying the Catalog Numbers.

(Example) Gearboxes



- Spur Gears
- Helical Gears
- Internal Gears
- Racks
- CP Racks & Pinions
- Miter Gears
- Bevel Gears
- Screw Gears
- Worm Gears
- Gearboxes**
- Other Products