



## Adjustment of tooth contact

### <Center of tooth contact>

- (1) Near the center of the tooth length for the length direction
- (2) Ideally, the tooth width direction should be at the center of the width or slightly closer to the toe.

When adjusting the backlash and mounting the gear in the case, adjust the case in order to achieve the tooth contact as shown in the figure below.

Deviation of the tooth contact from the normal position may adversely affect the strength and quietness.

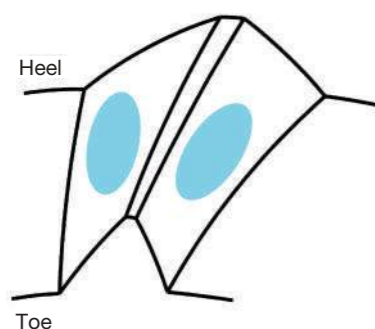

### (1) Tooth contact in case of a shaft-angle error

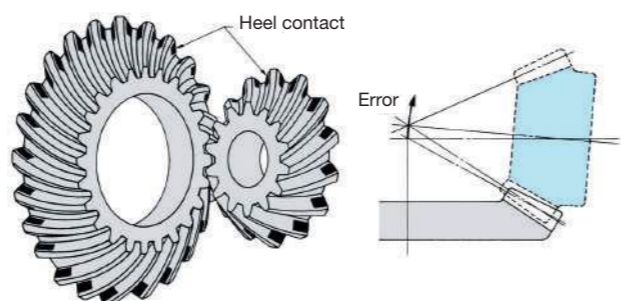
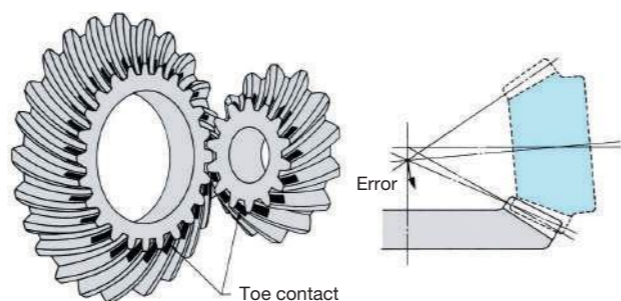

### (2) Tooth contact in case of a shaft-offset error

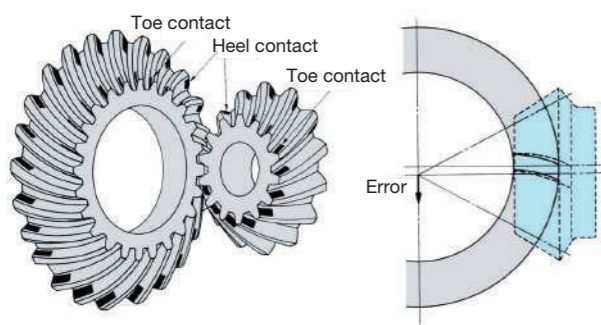
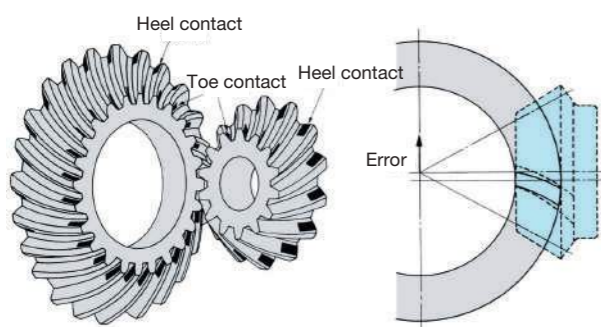

### (3) Tooth contact in case of a pinion set position error

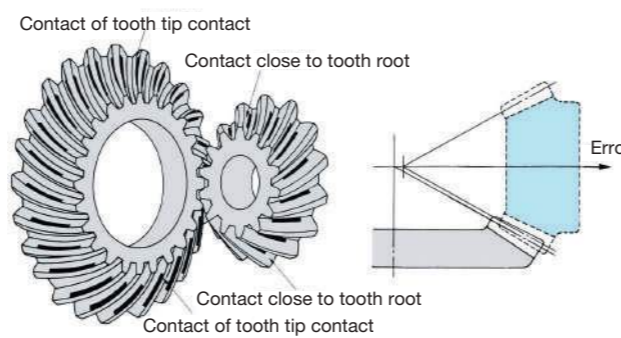
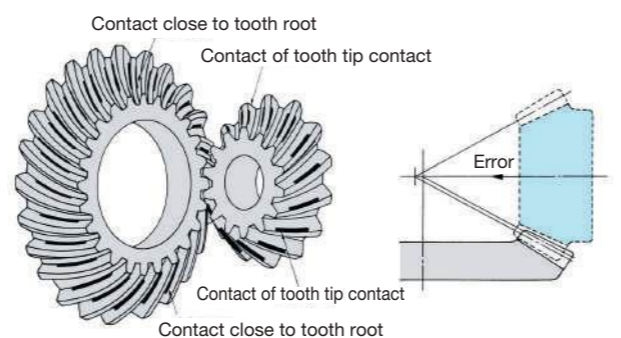

# Screw Gears

SN-H Hardened Screw Gears	SN Screw Gears	SUN Stainless Steel Screw Gears	AN Screw Gears	PN Plastic Screw Gears
Material: S45C m1-4 Page 384	Material: S45C m1-4 Page 384	Material: SUS303 m1-2.5 Page 388	Material: CAC702 (A&BC2) m1-3 Page 390	Material: MC901 m1-3 Page 392

**M** Includes Made to Order

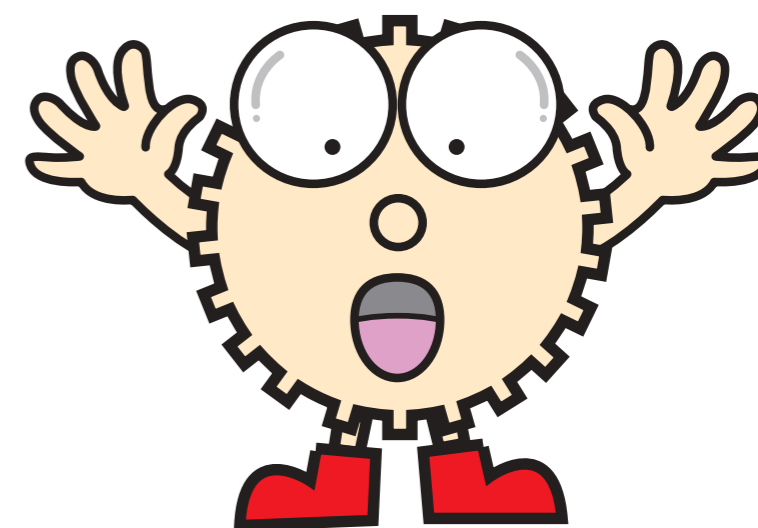

## Catalog Number of KHK Stock Gears

The Catalog Number for KHK stock gears is based on the simple formula listed below. Please order KHK gears by specifying the Catalog Numbers.

(Example) Screw Gears



### Features

KHK stock screw gears come in four materials, S45C, SUS303, CAC702 (old JIS A & BC2) and MC nylon, in modules 1~4 and numbers of teeth from 10 to 30.

Catalog Number	Module	Material	Heat Treatment	Tooth Surface Finish	Precision JIS B 1702-1:1998	Secondary Operations	Features
SN	1~4	S45C	—	Cut	N9	○	Many lineups are available at a low price. The teeth can be hardened.
SUN	1~2.5	SUS303	—	Cut	N9	○	Stainless steel gears with rust resistance.
AN	1~3	CAC702 (A & BC2)	—	Cut	N9	○	Aluminum bronze made gears with excellent wear resistance.
PN	1~3	MC901	—	Cut	N10	○	Nylon gears can be used with no lubrication.

○ Possible △ Partly possible × Not possible

### Application Examples

KHK stock screw gears are used in various labor-saving machines including conveyor machine and transport.

■ Design example of feeding device (not a design for machinery or a device in actual use)

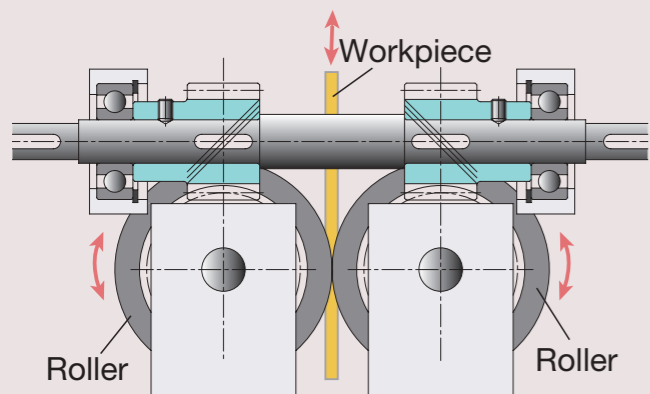

Rotate the roller in reverse with one input shaft and move the pinched workpiece vertically

### Selection Hints

Please select the most suitable products by carefully considering the characteristics of items and contents of the product tables. Since screw gears come in right- or left-hand helix, make sure to include the letter "R" or "L" in the catalog number when you order.

#### 1. Caution in Selecting the Mating Gears

Screw gears are used for offset shafts. Whether the shafts are paralleled offset or skewed offset depends on the helix directions of the mating gears.

Direction of shaft	Arrangement of helix hands
Skewed Axes	RH-RH or LH-LH
Parallel Axes	RH-LH

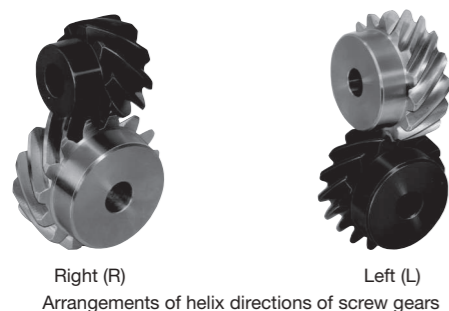

Right (R) Left (L)  
Arrangements of helix directions of screw gears

#### 2. Caution in Selecting Gears Based on Gear Strength

The allowable surface strengths listed in the product pages were derived using the Niemann formula as reference values. (Used with skewed shafts) There is a paucity of data on the strength of screw gears. The values of constant  $K_0$  used in the calculations, which depend on the material of the mating gears, are our estimates. The mathematic expression below shows the Niemann formula to determine allowable tangential force  $F_t$  (kgf) and allowable torque  $T$  (kgf·m) on a basic circle.

$$F_t = 1.43d_1^2 f_z K_s$$

$$T = \frac{F_t d_1}{2000}$$

Here,  $d_1$  : standard pitch diameter of pinion (mm)  
 $f_z$  : coefficient based on no. of teeth combination  
 $K_s$  : coefficient based on materials and sliding speed

$$K_s = K_0 \frac{2}{2 + V_s}$$

Here,  $K_0$  : coefficient based on material selection  
 $V_s$  : sliding speed (m/s)

$$V_s = \frac{\pi n d_1}{60000 \cos \beta}$$

Here,  $n$  : rotational speed (rpm)  
 $\beta$  : helix angle (45°)

#### ■ $f_z$ value

Z <sub>2</sub> \ Z <sub>1</sub>	10	13	15	20	26	30
10	1.538					
13	2.005	1.538				
15	2.279	1.786	1.538			
20	2.963	2.329	2.053	1.538		
26	3.695	2.963	2.588	2.005	1.538	
30	4.161	3.350	2.963	2.279	1.786	1.538

#### ■ Setting values depending on usage conditions

Catalog Number	Mating gear	$K_0$ value	Maximum allowable sliding speed m/s	No. of teeth of mating gears	Rotational Speed
SN	SN	0.0030	2.5	Same no. of teeth	100rpm
SUN	SN	0.0030 Note 1	2.5 Note 1		
AN	SN	0.0050	5		
PN	SN	0.0030 Note 1 (0.0021)	2.5 Note 1 (1.0)		

[NOTE 1]  $K_0$  values and the maximum allowable sliding speed of SUN & PN products are set by KHK. Screw gears are basically used with lubrication. In case of using PN products without lubrication, the parenthetical values shown in the table are applied.

### Application Hints

In order to use KHK stock screw gears safely, read the Application Hints carefully before proceeding. Please refer to Page 52 for "Cautions on Handling" and Page 53 for "Cautions on Starting". Please read "Cautions on Performing Secondary Operations" below when performing modifications and/or secondary operations for safety concerns.

#### 1. Caution on Performing Secondary Operations

- ① If re boring, it is important to pay special attention to locating the center in order to avoid runout.
- ② The reference datum for gear machining is the bore. Therefore, use the bore for locating the center. If it is too difficult to do for small bores, the alternative is to use one spot on the bore and the runout of the side surface.
- ③ If reworking using scroll chucks, we recommend the use of new or re bored jaws for improved precision. Please exercise caution not to crush the teeth.

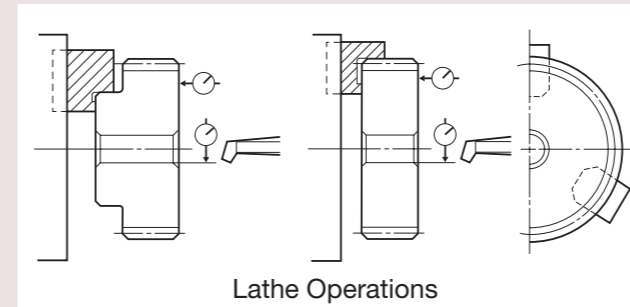

Lathe Operations

- ④ The maximum bore size is dictated by the requirement that the strength of the hub is to be higher than that of the gear teeth. The maximum bore size should be 60% to 70% of the hub diameter (or tooth root diameter), and 50% to 60% for keyway applied modifications.
- ⑤ In order to avoid stress concentration, round the keyway corners.

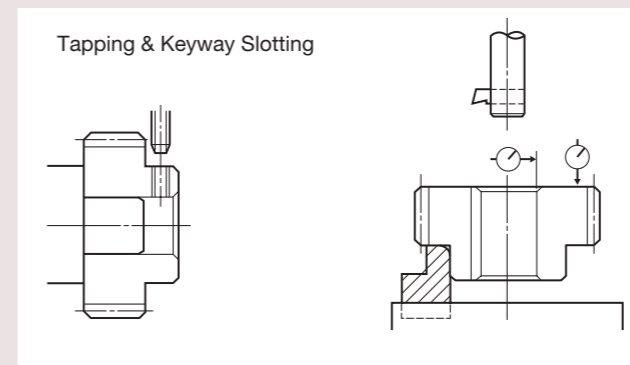

Tapping & Keyway Slotting

#### 2. Points of Caution during Assembly

- ① The recommended center distance tolerance of KHK stock screw gears is H7 for ground gears and H8 for cut gears. The amount of backlash is given in the product table for each gear.

$$a = \frac{d_1 + d_2}{2}$$

Where

$a$  : Center distance  
 $d_1$  : Pitch diameter of pinion  
 $d_2$  : Pitch diameter of gear

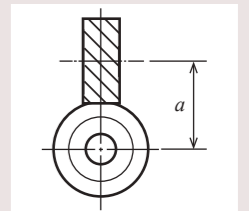

- ② Total Length Tolerance for Screw Gears

Total Length (mm)	Tolerance
30 or less	0 -0.10
31 to 100	0 -0.15

[NOTE] Hardened Plus, PN Plastic Screw Gears are excluded.

- ③ Due to the helix of screw gears, they produce axial thrust forces. The bearings must be selected properly to be able to handle these thrust forces. The directions of thrust change with the direction of helix and the direction of rotation as illustrated below. For details, use gear calculation software GCSW.

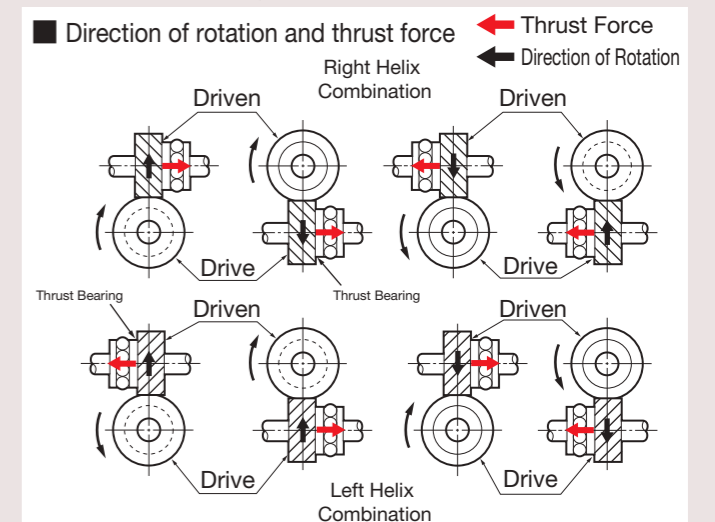

[NOTE] For parallel shaft applications, see the Application Hints for KHK Helical Gears (Page 195).

KHK considers safety a priority in the use of our products.

When handling, adding secondary operations, assembling, and operating KHK products, please be aware of the following issues in order to prevent accidents.

#### ⚠ Warning: Precautions for preventing physical and property damage

1. When using KHK products, follow relevant safety regulations (Occupational Safety and Health Regulations, etc.).
2. Pay attention to the following items when installing, removing, or performing maintenance and inspection of the product.
  - ① Turn off the power switch.
  - ② Do not reach or crawl under the product.
  - ③ Wear appropriate clothing and protective equipment for the work.

#### ⚠ Caution: Cautions in Preventing Accidents

1. Before using a KHK product, read the precautions in the catalog carefully in order to use it correctly.
2. Avoid use in environments that may adversely affect the product.
3. Our products are manufactured under a superior quality control system based on the ISO9001 quality management system; if you notice any malfunctions upon purchasing a product, please contact the supplier.

## Selecting the Gears

### Step 1

Determine the calculated load torque applied to the gear and the gear type suitable for the purpose.

### Step 2

Select provisionally from the allowable torque table in this catalog based on the load torque.

■ For provisional selection from this catalog

Catalog Number	Module	No. of Teeth	Pitch	Bore dia. (mm)	Pitch dia. (mm)	Outside dia. (mm)	Face width (mm)	Hole depth (mm)	Allowable torque				Backlash (mm)	Weight (kg)
									Surface durability	Surface durability (H)	Surface durability (L)	Surface durability (M)		
SN1-13R	13	R	6	15	18.38	20.38			0.19	0.019	0.41	0.04		0.030
SN1-15R	15	R	6	18	21.21	23.21			0.29	0.029	0.62	0.06	0.08-0.18	0.043
SN1-15L	m1	L	51	8	25	28.28	30.28	10	10	0.66	0.068	1.44	0.15	0.080
SN1-20R	20	R	6	25	28.28	30.28			1.42	0.14	3.08	0.31		0.13
SN1-26R	26	R	6	30	36.77	38.77			0.29	0.029	0.62	0.06		0.048
SN1-10L	10	L	51	8	16	21.21	24.21	15	10	0.62	0.063	1.34	0.14	0.088
SN1-13R	13	R	6	23	27.58	30.58			0.93	0.095	2.03	0.21	0.10-0.22	0.12
SN1-15R	15	R	6	25	31.82	34.82			2.14	0.22	4.64	0.47		0.20
SN1-20R	20	R	6	30	42.43	45.43			4.51	0.46	9.80	1.00		0.36
SN1-26R	26	R	6	40	55.15	58.15			6.75	0.69	14.7	1.50		0.48
SN1-30R	30	R	6	45	63.64	66.64			0.66	0.068	1.44	0.15		0.11
SN2-10R	10	R	6	22	28.28	32.28								
SN2-10L	10	L	6	22	28.28	32.28								

### Step 3

Calculate the strength under the actual usage conditions.

Calculate the strength formally using the various gear strength formulas. We recommend using the simple strength calculation available on our website.

■ Use the strength calculation function on our website.

### Surface durability

Calculated values of the strength at which the gear teeth do not wear due to surface fatigue damage.

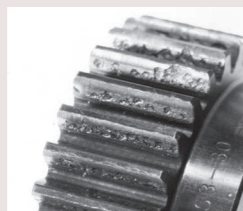

Example of wear due to insufficient surface durability

## Product Precautions



### Common Notes

#### [Caution on Product Characteristics]

- (1) The allowable torque shown in the table are calculated values according to the assumed usage conditions. Please see Page 380 for more details.
- (2) The backlash values shown in the table are the theoretical values for the backlash in the normal direction of a pair of identical gears in mesh.
- (3) Keyways are made according to JIS B1301 standards, Js9 tolerance. Also note that keyway tooth position alignment is not performed.
- (4) For products having a tapped hole, a set screw is included.
- (5) Variations in temperature or humidity can cause dimensional changes in plastic gears, including tooth diameter, bore, and backlash. The accuracy and tolerances shown in the catalog are values obtained when machining is performed.
- (6) When mating screw gears are made of the same material, they may cause abrasion and scoring. It is recommended to mate screw gears composed of different materials.
- (7) For offset shaft applications, match a RH with a RH, or LH with a LH, to make a set of screw gears. For parallel shaft applications, mesh opposite hands (RH and LH) of helical gear sets. See Page 380 for more details on selection precautions.
- (8) For bores of  $\phi$  4 or below, the bore tolerance is H8. As well, the tolerance is H8 for  $\phi$  5 or  $\phi$  6 bores with hole length (total length) 3x the bore or more.
- (9) These bevel gears produce axial thrust forces. Please see page 381 for more details.
- (10) See page 22 for more details on Hardened Plus (H Series and HJ Series).

#### ● KHK's Specifications for Heat Treatment

Hardened location: Tooth surface, or Tooth surface and Tooth root  
Hardness: 50 to 60 HRC

#### \* Hardness and Depth of Gear-teeth Induction Hardening

The hardening method and the state of the hardened teeth area vary depending on the size of gears. Since different hardening treatment is applied in accordance with the module and number of teeth, the hardness level is referred to as the hardness of the reference diameter. For some of our products, the hardness at tooth tip / root may not be equal to the hardness you designated. As to the effective case depth, it is specified by JIS, as "The distance from the surface of the case to the area with hardness HV450." The case depth differs from area to area of a tooth, so the depth cannot be specified. Due to the gear teeth being induction hardened, no secondary operations can be performed on tooth areas including the bottom land (approx. 2 to 3 mm).

#### [J Series]

- (1) Certain products which would otherwise have a very long tapped hole are counterbored. For details, see the KHK website.
- (2) Black oxide is not re-applied to parts undergoing secondary operations.

When selecting KHK standard gears, glance over the Product Precautions above and Cautions on Performing Secondary Operations on each page.

- ① Products not listed in this catalog or materials, modules, number of teeth and the like not listed in the dimensional tables can be manufactured as custom items. Please see Page 26 for more details.
- ② The color and shape of the product images listed on the dimension table page of each product may differ from the actual product. Be sure to confirm the shape in the dimension table before selection.
- ③ The details (specifications, dimensions, etc.) listed in the catalog may be changed without prior notice. Changes are announced on the KHK website.

Website URL: <https://khkgears.net/new/>  
Overseas Sales Department: Phone: +81-48-254-1744 Fax: +81-48-254-1765  
E-mail: [info@khkgears.net](mailto:info@khkgears.net)



Specifications	
Precision grade	JIS grade N9 (JIS B1702-1: 1998)*
Reference section of gear	Normal plane
Gear teeth	Standard full depth
Normal pressure angle	20°
Helix angle	45°
Material	S45C
Heat treatment	—
Surface treatment	Black oxide coating

\* The precision grade of J Series products is equivalent to the value shown in the table.

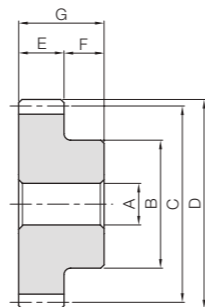

S1

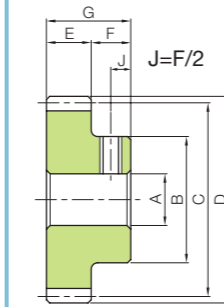

S1T

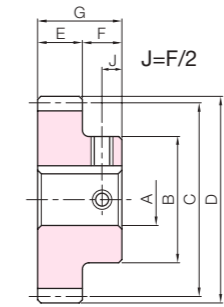

S1K



To order Hardened Plus, please specify **Catalog No. + H**. Example: **SN1-13RH**

Catalog Number	Module	No. of teeth	Direction of helix	Shape	Bore	Hub dia.	Pitch dia.	Outside dia.	Face width	Hub width	Total length	Allowable torque				Backlash (mm)	Weight (kg)								
												Surface durability		Surface durability <b>H</b>											
												N·m	kgf·m	N·m	kgf·m										
SN1-13R SN1-13L	m1	13	R	S1	6	15	18.38	20.38	10	10	20	0.19	0.019	0.41	0.04	0.08~0.18	0.030								
SN1-15R SN1-15L			L									18	21.21	23.21	0.29			0.029	0.62	0.06					
SN1-20R SN1-20L		20	R			8	25	28.28				30.28	0.66	0.068	1.44			0.15							
SN1-26R SN1-26L			L										10	30	36.77			38.77	1.42	0.14	3.08	0.31			
SN1.5-10R SN1.5-10L		m1.5	10			R	S1	10				16	21.21	24.21	15			10	25	0.29	0.029	0.62	0.06	0.10~0.22	0.048
SN1.5-13R SN1.5-13L						L														23	27.58	30.58	0.62		
SN1.5-15R SN1.5-15L	15		R	25	31.82	34.82			0.93	0.095	2.03	0.21													
SN1.5-20R SN1.5-20L			L						30	42.43	45.43	2.14	0.22	4.64		0.47									
SN1.5-26R SN1.5-26L	26		R	40	55.15	58.15			4.51	0.46	9.80	1.00													
SN1.5-30R SN1.5-30L			L						45	63.64	66.64	6.75	0.69	14.7		1.50									
SN2-10R SN2-10L	m2	10	R	S1	12	22	28.28	32.28	20	15	35	0.66	0.068	1.44	0.15	0.12~0.26	0.11								
SN2-13R SN2-13L			L									30	36.77	40.77	1.42			0.14	3.08	0.31					
SN2-15R SN2-15L		15	R			35	42.43	46.43				2.14	0.22	4.64	0.47										
SN2-20R SN2-20L			L									45	56.57	60.57	4.84			0.49	10.5	1.07					
SN2-26R SN2-26L		26	R			60	73.54	77.54				10.1	1.03	22.0	2.24										
SN2-30R SN2-30L			L									65	84.85	88.85	15.0			1.53	32.7	3.34					

[Caution on Secondary Operations] ① See Page 22 for more details on Hardened Plus (H Series and HJ Series).

To order J Series products, please specify: **Catalog No. + J + BORE**. Example: **SN1-13RJ6**

Catalog Number	Bore H7		* The product shapes of J Series items are identified by background color.																			
	Keyway J <sub>59</sub>		6	8	10	12	14	15	16	17	18	19	20	22	25	28	30	32	35			
	Screw size		4×1.8				5×2.3				6×2.8				8×3.3				10×3.3			
	M4	M5	M4				M5				M6				M8							
SN1-13R J BORE	*																					
SN1-13L J BORE	*																					
SN1-15R J BORE	*																					
SN1-15L J BORE	*																					
SN1-20R J BORE		*																				
SN1-20L J BORE		*																				
SN1-26R J BORE			*																			
SN1-26L J BORE			*																			
SN1.5-10R J BORE		*																				
SN1.5-10L J BORE		*																				
SN1.5-13R J BORE			*																			
SN1.5-13L J BORE			*																			
SN1.5-15R J BORE			*																			
SN1.5-15L J BORE			*																			
SN1.5-20R J BORE				*																		
SN1.5-20L J BORE				*																		
SN1.5-26R J BORE				*																		
SN1.5-26L J BORE				*																		
SN1.5-30R J BORE				*																		
SN1.5-30L J BORE				*																		
SN2-10R J BORE				*																		
SN2-10L J BORE				*																		
SN2-13R J BORE				*																		
SN2-13L J BORE				*																		
SN2-15R J BORE				*																		
SN2-15L J BORE				*																		
SN2-20R J BORE					*																	
SN2-20L J BORE					*																	
SN2-26R J BORE						*																
SN2-26L J BORE						*																
SN2-30R J BORE						*																
SN2-30L J BORE						*																

To order J Series Hardened Plus products, please specify: **Catalog No. + H + J + BORE**. Example: **SN1-15RHJ8**

[Caution on J series] ① Cancellation is not possible for made-to-order products. See page 42 for lead times and allowable order quantities. See page 44 for other precautions.  
② "\*" is a product with the original bore diameter, so Hardened Plus is not available. See Page 22 for more details on Hardened Plus.





Specifications	
Precision grade	JIS grade N9 (JIS B1702-1: 1998)
Reference section of gear	Normal plane
Gear teeth	Standard full depth
Normal pressure angle	20°
Helix angle	45°
Material	SUS303
Heat treatment	—

\* The precision grade of J Series products is equivalent to the value shown in the table.

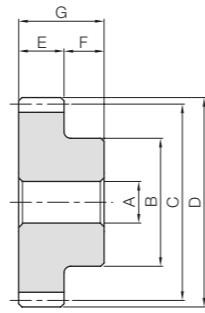

S1

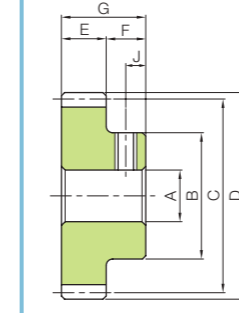

S1T

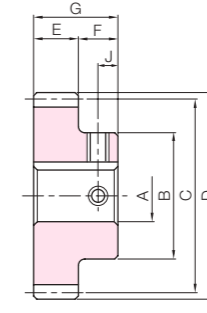

S1K



To order J Series products, please specify: **Catalog No. + J + BORE.**

Catalog Number	Module	No. of teeth	Direction of helix	Shape	Bore		Pitch dia.	Outside dia.	Face width	Hub width	Total length	Allowable torque (N·m)	Allowable torque (kgf·m)	Backlash (mm)	Weight (kg)		
					AH7	B											
SUN1-13R SUN1-13L	m1	13	R L	S1	6	15	18.38	20.38	10	10	20	0.19	0.019	0.08~0.18	0.031		
SUN1-15R SUN1-15L		15	R L			18	21.21	23.21								0.29	0.029
SUN1.5-10R SUN1.5-10L	m1.5	10	R L	S1	8	16	21.21	24.21	15	10	25	0.29	0.029	0.10~0.22	0.048		
SUN1.5-13R SUN1.5-13L		13	R L			23	27.58	30.58								0.62	0.063
SUN1.5-15R SUN1.5-15L		15	R L			25	31.82	34.82								0.93	0.095
SUN1.5-20R SUN1.5-20L		20	R L			12	30	42.43								45.43	2.14
SUN2-10R SUN2-10L	m2	10	R L	S1	12	22	28.28	32.28	20	15	35	0.66	0.068	0.12~0.26	0.11		
SUN2-13R SUN2-13L		13	R L			30	36.77	40.77								1.42	0.14
SUN2-15R SUN2-15L		15	R L			35	42.43	46.43								2.14	0.22
SUN2-20R SUN2-20L		20	R L			15	45	56.57								60.57	4.84
SUN2.5-15R SUN2.5-15L	m2.5	15	R L	S1	15	40	53.03	58.03	22	16	38	4.03	0.41	0.14~0.28	0.49		
SUN2.5-20R SUN2.5-20L		20	R L			60	70.71	75.71								9.07	0.92

Bore H7	* The product shapes of J Series items are identified by background color.																
	6	8	10	12	14	15	16	17	18	19	20	22	25	28	30	32	35
Keyway JS9	—		4x1.8		5x2.3			6x2.8			8x3.3		10x3.3				
Screw size	—		4x1.8		5x2.3			6x2.8			8x3.3		10x3.3				
Catalog Number	M4	M5	M4			M5			M6		M8						
SUN1-13RJ BORE																	
SUN1-13LJ BORE																	
SUN1-15RJ BORE																	
SUN1-15LJ BORE																	
SUN1.5-10RJ BORE																	
SUN1.5-10LJ BORE																	
SUN1.5-13RJ BORE																	
SUN1.5-13LJ BORE																	
SUN1.5-15RJ BORE																	
SUN1.5-15LJ BORE																	
SUN1.5-20RJ BORE																	
SUN1.5-20LJ BORE																	
SUN2-10RJ BORE																	
SUN2-10LJ BORE																	
SUN2-13RJ BORE																	
SUN2-13LJ BORE																	
SUN2-15RJ BORE																	
SUN2-15LJ BORE																	
SUN2-20RJ BORE																	
SUN2-20LJ BORE																	
SUN2.5-15RJ BORE																	
SUN2.5-15LJ BORE																	
SUN2.5-20RJ BORE																	
SUN2.5-20LJ BORE																	

[Caution on J series] ① Cancellation is not possible for made-to-order products. See page 42 for lead times and allowable order quantities. See page 44 for other precautions.





Specifications	
Precision grade	JIS grade N9 (JIS B1702-1: 1998) *
Reference section of gear	Normal plane
Gear teeth	Standard full depth
Normal pressure angle	20°
Helix angle	45°
Material	CAC702 (old JIS A & BC2)
Heat Treatment	—

\* The precision grade of J Series products is equivalent to the value shown in the table.

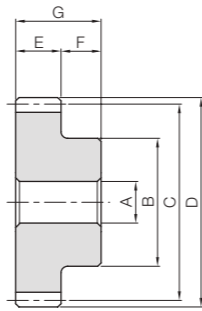

S1

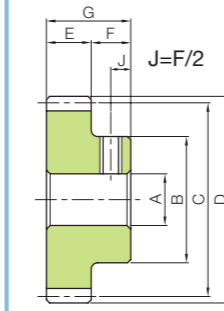

S1T

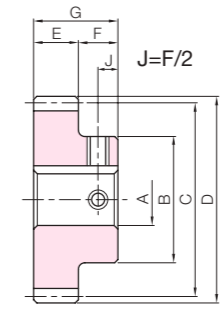

S1K



To order J Series products, please specify: **Catalog No. + J + BORE.**

Catalog Number	Module	No. of teeth	Direction of helix	Shape	Bore		Pitch dia.	Outside dia.	Face width	Hub width	Total length	Allowable torque (N·m)	Allowable torque (kgf·m)	Backlash (mm)	Weight (kg)		
					AH7	B											
AN1-13R AN1-13L	m1	13	R L	S1	6	15	18.38	20.38	10	10	20	0.31	0.032	0.08~0.18	0.029		
AN1-15R AN1-15L		15	R L			18	21.21	23.21								0.48	0.049
AN1.5-10R AN1.5-10L	m1.5	10	R L	S1	8	16	21.21	24.21	15	10	25	0.48	0.049	0.10~0.22	0.046		
AN1.5-13R AN1.5-13L		13	R L			23	27.58	30.58								1.03	0.10
AN1.5-15R AN1.5-15L		15	R L			25	31.82	34.82								1.55	0.16
AN2-10R AN2-10L	m2	10	R L	S1	12	22	28.28	32.28	20	15	35	1.10	0.11	0.12~0.26	0.11		
AN2-13R AN2-13L		13	R L			30	36.77	40.77								2.36	0.24
AN2-15R AN2-15L		15	R L			35	42.43	46.43								3.56	0.36
AN2.5-10R (Made to Order) AN2.5-10L (Made to Order)	m2.5	10	R L	S1	12	26	35.36	40.36	22	16	38	2.11	0.22	0.14~0.28	0.20		
AN2.5-13R (Made to Order) AN2.5-13L (Made to Order)		13	R L			35	45.96	50.96								4.47	0.46
AN2.5-15R (Made to Order) AN2.5-15L (Made to Order)		15	R L			40	53.03	58.03								6.72	0.69
AN3-10R (Made to Order) AN3-10L (Made to Order)	m3	10	R L	S1	15	34	42.43	48.43	25	18	43	3.56	0.36	0.14~0.32	0.34		
AN3-13R (Made to Order) AN3-13L (Made to Order)		13	R L			45	55.15	61.15								7.51	0.77
AN3-15R (Made to Order) AN3-15L (Made to Order)		15	R L			50	63.64	69.64								11.3	1.15

[Precautions for Made to Order Products] ① Prices and lead times for Made to Order products require separate estimates. Contact your dealer.

Bore H7	* The product shapes of J Series items are identified by background color.															
	6	8	10	12	14	15	16	17	18	19	20	22	25	28	30	
Keyway JS9	—		4x1.8		5x2.3			6x2.8			8x3.3					
Screw size	—		4x1.8		5x2.3			6x2.8			8x3.3					
Catalog Number	M4	M5	M4			M5			M6							
AN1-13RJ BORE																
AN1-13LJ BORE																
AN1-15RJ BORE																
AN1-15LJ BORE																
AN1.5-10RJ BORE																
AN1.5-10LJ BORE																
AN1.5-13RJ BORE																
AN1.5-13LJ BORE																
AN1.5-15RJ BORE																
AN1.5-15LJ BORE																
AN2-10RJ BORE																
AN2-10LJ BORE																
AN2-13RJ BORE																
AN2-13LJ BORE																
AN2-15RJ BORE																
AN2-15LJ BORE																

[Caution on J series] ① Cancellation is not possible for made-to-order products. See page 42 for lead times and allowable order quantities. See page 44 for other precautions.



Specifications	
Precision grade	JIS grade N10 (JIS B1702-1:1998)*
Reference section of gear	Normal plane
Gear teeth	Standard full depth
Normal pressure angle	20°
Helix angle	45°
Material	MC901
Heat treatment	—

\* The precision grade is equivalent to the value shown in the table.

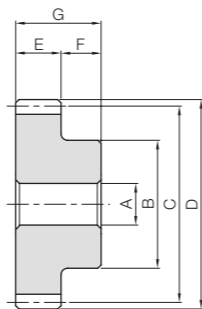

S1

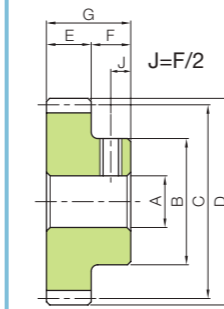

S1T

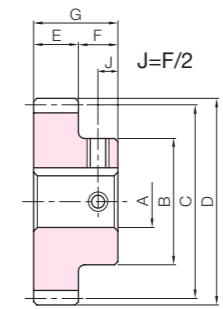

S1K



To order J Series products, please specify: **Catalog No. + J + BORE.**

Catalog Number	Module	No. of teeth	Direction of helix	Shape	Bore		Pitch dia.	Outside dia.	Face width	Hub width	Total length	Allowable torque (N·m)	Allowable torque (kgf·m)	Backlash (mm)	Weight (kg)			
					A <sub>H8</sub>	B												
PN1-13R PN1-13L	m1	13	R L	S1	6	15	18.38	20.38	10	10	20	0.19	0.019	0.18~0.32	0.0045			
PN1-15R PN1-15L		15	R L			18	21.21	23.21								0.29	0.029	0.20~0.34
PN1-20R PN1-20L		20	R L			8	25	28.28										
PN1.5-10R PN1.5-10L	m1.5	10	R L	S1	6	16	21.21	24.21	15	10	25	0.29	0.029	0~0.38	0.0077			
PN1.5-13R PN1.5-13L		13	R L			23	27.58	30.58								0.62	0.063	
PN1.5-15R PN1.5-15L		15	R L			25	31.82	34.82										0.93
PN1.5-20R PN1.5-20L		20	R L			10	30	42.43								45.43	2.14	
PN2-10R PN2-10L	m2	10	R L	S1	10	22	28.28	32.28	20	15	35	0.66	0.068	0~0.42	0.018			
PN2-13R PN2-13L		13	R L			30	36.77	40.77								1.42	0.14	
PN2-15R PN2-15L		15	R L			35	42.43	46.43										2.14
PN2-20R PN2-20L		20	R L			12	45	56.57								60.57	4.84	
PN2.5-13R PN2.5-13L	m2.5	13	R L	S1	12	35	45.96	50.96	22	16	38	2.68	0.27	0~0.44	0.055			
PN2.5-15R PN2.5-15L		15	R L			40	53.03	58.03								4.03	0.41	
PN2.5-20R PN2.5-20L		20	R L			60	70.71	75.71										9.07
PN3-10R PN3-10L	m3	10	R L	S1	12	34	42.43	48.43	25	18	43	2.14	0.22	0~0.52	0.054			
PN3-15R PN3-15L		15	R L			50	63.64	69.64								6.75	0.69	0~0.54

Bore H8	* The product shapes of J Series items are identified by background color.																
	6	8	10	12	14	15	16	17	18	19	20	22	25	28	30	32	35
Keyway J <sub>S9</sub>	—		4x1.8			5x2.3			6x2.8			8x3.3			10x3.3		
Screw size	—		M4			M5			M6			M8			M10		
Catalog Number	M4	M5	M4			M5			M6			M8			M10		
PN1-13RJ BORE																	
PN1-13LJ BORE																	
PN1-15RJ BORE																	
PN1-15LJ BORE																	
PN1-20RJ BORE																	
PN1-20LJ BORE																	
PN1.5-10RJ BORE																	
PN1.5-10LJ BORE																	
PN1.5-13RJ BORE																	
PN1.5-13LJ BORE																	
PN1.5-15RJ BORE																	
PN1.5-15LJ BORE																	
PN1.5-20RJ BORE																	
PN1.5-20LJ BORE																	
PN2-10RJ BORE																	
PN2-10LJ BORE																	
PN2-13RJ BORE																	
PN2-13LJ BORE																	
PN2-15RJ BORE																	
PN2-15LJ BORE																	
PN2-20RJ BORE																	
PN2-20LJ BORE																	
PN2.5-13RJ BORE																	
PN2.5-13LJ BORE																	
PN2.5-15RJ BORE																	
PN2.5-15LJ BORE																	
PN2.5-20RJ BORE																	
PN2.5-20LJ BORE																	
PN3-10RJ BORE																	
PN3-10LJ BORE																	
PN3-15RJ BORE																	
PN3-15LJ BORE																	

- [Caution on J series] ① Cancellation is not possible for made-to-order products. See page 42 for lead times and allowable order quantities. See page 44 for other precautions.  
 ② Since tapped holes of plastic products are easily damaged, avoid overtightening when fastening screws. For products with a short tapped hole, tighten screws to a torque of less than 0.12 N·m for M4 threads, and 0.38 N·m for M5 threads.

\* In regard to MC Nylon gears, other materials are available for plastic gears, including Ultra High Molecular Weight Polyethylene (U-PE), which has excellent abrasion resistance and resin conforming to the Plastic Implementation Measure (PIM). A single piece order is acceptable and will be produced as a custom-made gear. Please see Page 26 for more details on quotations and orders.

# GCU-N Screw Gear Kit



Installation : Nonparallel and nonintersecting gears  
 Gear Type : Screw Gears  
 Gears : SN2.5-10R  
 PN2.5-10R equivalent  
 Gear Ratio : 1  
 Weight : Approx. 1kg

Screw Gears are helical gears used in nonparallel and nonintersecting situations. Applications include devices like conveyers with light loads.

\* This is not a gear box for actual use to transmit power. Please use only as representations of gear systems.

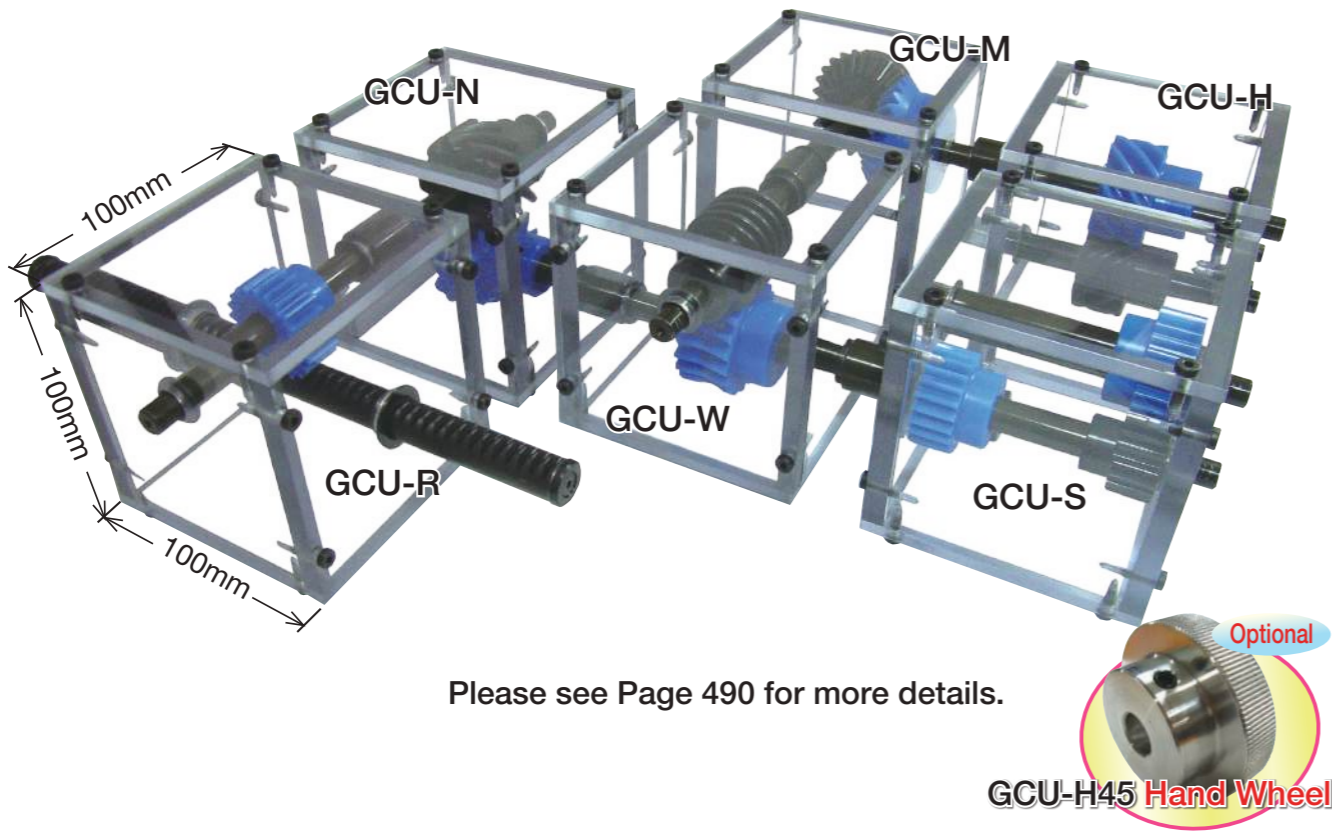

Please see Page 490 for more details.

GCU-H45 Hand Wheel



# Worm Gears

<b>KWGD/LKWDLS</b> Duplex Worms <i>NEW</i>	<b>AGDL</b> Duplex Worm Wheels Reduction Ratio 20-40 <i>NEW</i>	<b>KWG</b> Ground Worm Shafts	<b>AG</b> Worm Wheels Reduction Ratio 10-60	<b>AGF</b> Worm Wheels Reduction Ratio 10-60	<b>SWG</b> Ground Worms	<b>AG</b> Worm Wheels Reduction Ratio 10-60 <i>NEW</i>	<b>SW</b> Worms
Material: SCM440 m1.5-6 Page 406	Material: CAC702(A1BC2) m1.5-6 Page 406	Material: SCM440 m0.5-6 Page 416	Material: CAC702(A1BC2) m0.5-1.5 Page 416	Material: CAC702(A1BC2) m2-6 Page 420	Material: S45C m1-6 Page 426	Material: CAC702(A1BC2) m1-6 Page 426	Material: S45C m0.5-10 Page 434
<b>BG</b> Worm Wheels Reduction Ratio 10-60	<b>CG</b> Worm Wheels Reduction Ratio 15-120 <i>NEW</i>	<b>SUW</b> Stainless Steel Worms	<b>PG</b> Worm Wheels Reduction Ratio 10-60				
Material: CAC502(PBC2) m0.5-6 Page 434	Material: FC200 m1-10 Page 436	Material: SUS303 m0.5-3 Page 454	Material: MC901 m0.5-3 Page 454				

**M** Includes Made to Order

## Catalog Number of KHK Stock Gears

The Catalog Number for KHK stock gears is based on the simple formula listed below. Please order KHK gears by specifying the Catalog Numbers.

(Example) Worm Gear Pair

Worms

**K W G DL 2 - R1**

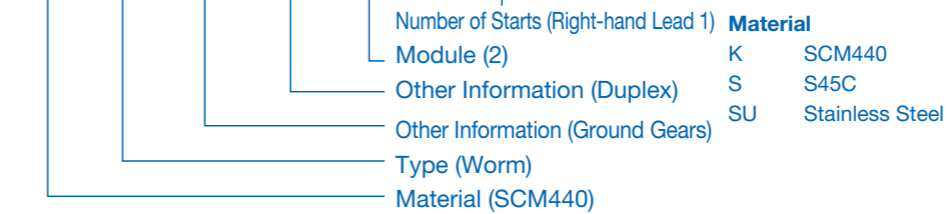

Number of Starts (Right-hand Lead 1) **Material**  
 Module (2) **Type**  
 Other Information (Duplex) **Other Information**  
 Other Information (Ground Gears) **DL** Duplex  
 Type (Worm) **G** Ground Gears  
 Material (SCM440) **S** Pinion Shafts

**Material**  
 K SCM440  
 S S45C  
 SU Stainless Steel

**Type**  
 W Worms

**Other Information**  
 DL Duplex  
 G Ground Gears  
 S Pinion Shafts

**Material**  
 A CAC702  
 B CAC502  
 C FC200  
 P MC901

**Type**  
 G Worm Wheels  
**Other Information**  
 DL Duplex  
 F Double Hubs or Ring Gears

Number of Starts (Right-hand Lead 1) **Material**  
 No. of Teeth (20) **Type**  
 Module (2) **Other Information**  
 Other Information (Duplex) **DL** Duplex  
 Type (Worm Wheel) **F** Double Hubs or Ring Gears  
 Material (CAC702)

**Material**  
 A CAC702  
 B CAC502  
 C FC200  
 P MC901

**Type**  
 G Worm Wheels  
**Other Information**  
 DL Duplex  
 F Double Hubs or Ring Gears

**Material**  
 A CAC702  
 B CAC502  
 C FC200  
 P MC901

**Type**  
 G Worm Wheels  
**Other Information**  
 DL Duplex  
 F Double Hubs or Ring Gears

Number of Starts (Right-hand Lead 1) **Material**  
 No. of Teeth (20) **Type**  
 Module (2) **Other Information**  
 Other Information (Duplex) **DL** Duplex  
 Type (Worm Wheel) **F** Double Hubs or Ring Gears  
 Material (CAC702)

**Material**  
 A CAC702  
 B CAC502  
 C FC200  
 P MC901

**Type**  
 G Worm Wheels  
**Other Information**  
 DL Duplex  
 F Double Hubs or Ring Gears