

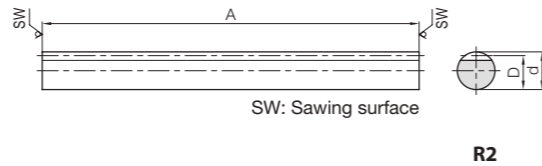

Specifications	
Precision grade	KHK R 001 grade 4
Gear teeth	Standard full depth
Pressure angle	20°
Material	S45C
Heat treatment	—
Tooth hardness	(less than 210HB)
Surface treatment	Black oxide coating



Catalog Number	Pitch mm (Module)	Effective number of teeth	Shape	Total Length			Allowable force (N)		Allowable force (kgf)		Backlash (mm)	Weight (kg)
				A	d <sub>h9</sub>	D	Bending strength	Surface durability	Bending strength	Surface durability		
<b>SROCP2.5-500</b>	<b>CP2.5</b> (0.7958)	200	R2	505	10	9.2	474	91.8	48.3	9.36	0.00~0.14	0.30
<b>SROCP5-500</b>	<b>CP5</b> (1.5915)	99	R2	505	15	13.41	1650	324	169	33.1	0.09~0.25	0.65
<b>SROCP10-1000</b>	<b>CP10</b> (3.1831)	99	R2	1010	30	26.82	6610	1300	674	132	0.14~0.35	5.16

[Caution on Product Characteristics] ① Because this is extruded material, the outer diameter may be out of H9 tolerance in sections.  
 [Caution on Secondary Operations] ① Avoid hardening round racks, due to twisting and deformation occurring and the difficulty of straightening the rack after hardening.

FRCP Circular pitch 5  
CP Metal Flexible Racks



Specifications	
Precision grade	KHK R 001 grade 8
Gear teeth	Standard full depth
Pressure angle	20°
Material	SS400
Heat treatment	—
Tooth hardness	(less than 187HB)
Surface treatment	Black oxide coating

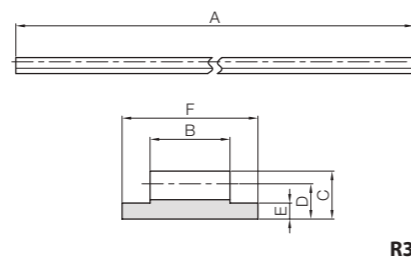

Catalog Number	Pitch mm (Module)	Shape	Total Length			Height to pitch line	Base thickness	Base width	Allowable force (N)		Allowable force (kgf)	Weight (kg)	
			A	B	C				D	E			F
<b>FRCP5-2000*</b>	<b>CP5</b> (1.5915)	R3	2000	10	6	4.41	2	17	801	81.7		0.91	
<b>FRCP5-3000*</b>			3000										1.37
<b>FRCP5-4000*</b>			4000										1.83

[Caution on Product Characteristics] ① When using the metal flexible rack in an arc, the minimum bending radius (R) is 150 mm for both the external and internal teeth. Using a smaller radius increases the pitch errors and tooth profile errors which prevent the teeth from meshing at the normal center distance, so be sure to make adjustments before use.  
 ② The tolerance of height (size C) is 0 to -0.15, and the tolerance of base width (size F) is 0 to -0.1.  
 ③ It cannot be used where positioning accuracy is required.

Installation Example of FRCP Metal Flex Rack

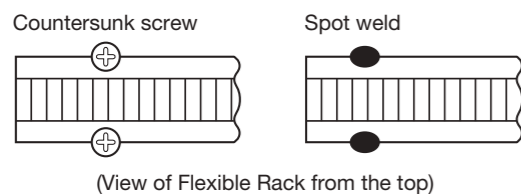

Recommended Mating Pinions



SSCP

Please see Page 294 for more details.

Ⓞ Note that products with an asterisk (\*) after the catalog number will no longer be manufactured after 20 June, 2026.

# Miter Gears

MMSGQ	MMSG	SMSG	MMSA/MMSB	MMS	SMS	SMA/SMB/SMC	MM
Ground Spiral Miter Gears	Ground Spiral Miter Gears	Ground Spiral Miter Gears	Finished Bore Spiral Miter Gears	Spiral Miter Gears	Spiral Miter Gears	Finished Bore Miter Gears	Miter Gears
Material: SCM415 m2-4 Page 314	Material: SCM415 m2-4 Page 316	Material: S45C m1-4 Page 318	Material: SCM415 m1-10 Page 320	Material: SCM415 m2-5 Page 322	Material: S45C m1-8 Page 324	Material: S45C m1-5 Page 326	Material: SCM415 m2-5 Page 328
LM	SM-H	SM	SAM-H	SAM	SUM	SUMA	PM
Sintered Metal Miter Gears	Hardened Miter Gears	Miter Gears	Hardened Angular Miter Gears	Angular Miter Gears	Stainless Steel Miter Gears	Finished Bore Stainless Steel Miter Gears	Plastic Miter Gears
Material: SMF5040 m0.8-1.5 Page 328	Material: S45C m1-8 Page 330	Material: S45C m1-8 Page 330	Material: S45C m1.5-3 Page 332	Material: S45C m1.5-3 Page 332	Material: SUS303 m1-4 Page 334	Material: SUS303 m1-4 Page 334	Material: MC901 m1-4 Page 336
DM	BB	Nissei KSP					
Injection Molded Miter Gears	Sintered Metal Bushings	Ground Spiral Miter					
Material: Duracon (R) (M90-44) m0.5-1.5 Page 336	Material: Oil-free copper alloy φ 5-8 Page 338	Material: SCM415 m1.5-6 Page 374					

Catalog Number of KHK Stock Gears

The Catalog Number for KHK stock gears is based on the simple formula listed below. Please order KHK gears by specifying the Catalog Numbers.

(Example) Miter Gears

M MS G 2 - 20 R



Material	Type
S S45C	M Straight Miter Gears
M SCM415	MS Spiral Miter Gears
SU Stainless Steel	AM Angular Miter Gears
L Sintered Metal Alloy	
P MC901	
D Polyacetal	
	<b>Other Information</b>
	G, GQ Ground Gears

## Features



Miter gears are a special class of bevel gears where the shafts intersect at 90° and the gear ratio is 1:1. KHK stock miter gears are available in two types, straight miter and spiral miter, with high precision grade for demanding torques and speeds, and commercial grade for economical applications. The following table lists the main features for easy selection.

Type	Catalog Number	Module	No. of Teeth ( ) Shaft Angle	Material	Heat Treatment	Tooth Surface Finish	Precision JIS B 1704: 1978	Secondary Operations	Features
Spiral Miter Gears	<b>MMSGQ</b>	2~4	20, 30	SCM415	Carburized Note 1	Ground	0	△	Gears that have been hardened and ground that has grade-0 accuracy, strength, abrasion resistance and quietness. Secondary operations can be given except for the teeth.
	<b>MMSG</b>	2~4	20, 25, 30	SCM415	Carburized Note 1	Ground	1	△	Gears that have been hardened and ground that has excellent accuracy, strength and abrasion resistance. Secondary operations can be given except for the teeth.
	<b>SMSG</b>	1~4	20, 25, 30	S45C	Gear teeth induction hardened	Ground	2	△	Gears that have been hardened and ground that has excellent abrasion resistance. Secondary operations can be given except for the teeth.
	<b>KSP</b>	1.5~6	20~30	SCM415	Carburized Note 1	Ground	0	△	Gears that have been hardened and ground that has grade-0 accuracy, strength, abrasion resistance and quietness. Secondary operations can be given except for the teeth.
	<b>MMSA/MMSB</b>	1~10	20	SCM415	Carburized Note 1	Cut	4	×	Gears that have been fully hardened that have excellent strength and wear resistance. Can be used in the finished shape.
	<b>MMS</b>	2~5	20, 25, 30	SCM415	Carburized Note 1	Cut	4	△	Gears that have been hardened that have excellent strength and wear resistance. Secondary operations are possible except for the teeth.
	<b>SMS</b>	1~5	20, 25, 30	S45C	Gear teeth induction hardened	Cut	4	△	Gears that have been hardened with excellent wear resistance. Secondary operations are possible except for the teeth.
Straight Miter Gears	<b>SMA/SMB/SMC</b>	1~8	20, 25, 30	S45C	Gear teeth induction hardened	Cut	4	△	Gears that have been hardened with excellent wear resistance. Can be used in the finished shape.
	<b>MM</b>	2~5	20, 25, 30	SCM415	Carburized Note 1	Cut	4	△	Gears that have been hardened that have excellent strength and wear resistance. Secondary operations are possible except for the teeth.
	<b>LM</b>	0.8~1.5	20	SMF5040 (S45C equivalent)	—	Sintered	5	○	Small gears made through sintering.
	<b>SM</b>	1~8	16, 20, 25, 30	S45C	—	Cut	3	○	Many lineups are available. The teeth can be additionally hardened.
	<b>SAM</b>	1.5~3	20 (45°, 60°, 120°)	S45C	—	Cut	3	○	3 types of angular miter are available for shafts at 45°, 60° and 120°.
	<b>SUM</b>	1~4	20, 25, 30	SUS303	—	Cut	3	○	Stainless steel gears with rust resistance.
	<b>SUMA</b>	1~4	20, 25	SUS303	—	Cut	3	△	Stainless steel gears with rust resistance. Keyways and tapping provided.
	<b>PM</b>	1~4	20, 25	MC901	—	Cut	4	○	Nylon gears can be used with no lubrication.
<b>DM</b>	0.5~1.5	20	Duracon (R) (M90-44) NOTE 2	—	Injection Molded	6	△	Low-priced gears made through injection molding. Suitable for light loads.	

[NOTE 1] Although these are carburized products, secondary operations can be performed on the areas where are masked during the carburization. However, note that high hardness (HRC40 at maximum) occurs in some cases.   
 [NOTE 2] "Duracon (R)" is a registered trademark of Polyplastics Co., Ltd. in Japan as well as other countries.

○ Possible △ Partly possible × Not possible

## We use the Crowning method for gear cutting

KHK utilizes Gleason Coniflex No.104 and 114 bevel gear generating machinery, and is equipped for mass production of straight miter gears. You can count on a stable supply of straight miter gears from KHK

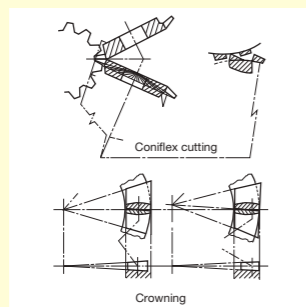

Gleason Coniflex No.104

## Application Examples



Miter gears are used in driving components with intersecting axes in transport devices, industrial machines, etc.

### ■ Masdac Dorayaki Machine



SM miter gears used for reversing fabrics

### ■ Carton former

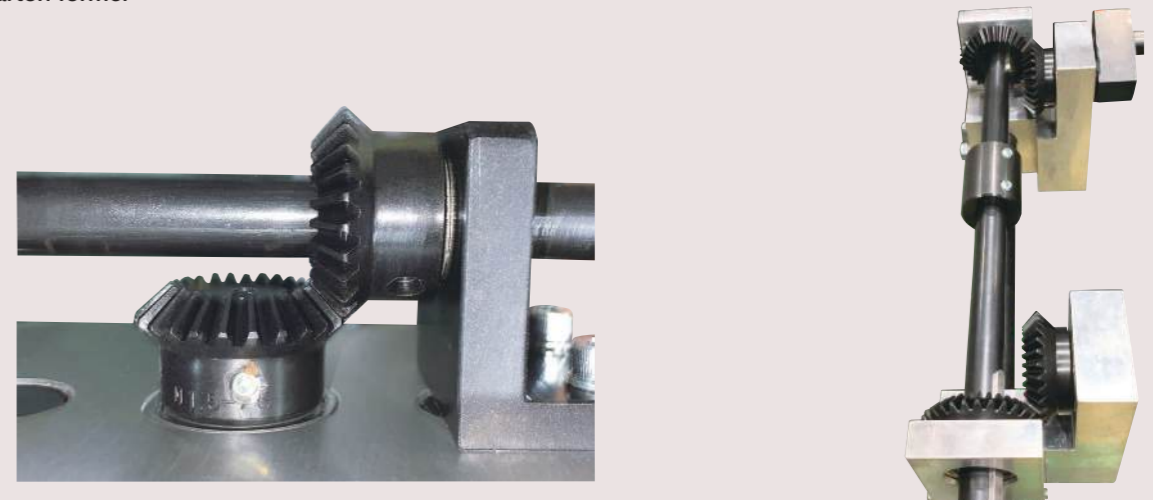

SM and SMB miters used to drive X/Y axes and transmit mechanical power

### ■ Fish processing machine manufactured by TOYO SUISAN KIKAI CO.,LTD. ■ Angular Miter Gear Box



SMB miter used for filleting fish



Selection Hints

Please select the most suitable products by carefully considering the characteristics of items and contents of the product tables. It is also important to read all applicable "CAUTION" notes shown below before the final selection.

1. Caution in Selecting the Mating Gears

Among KHK stock miter gears, there are products which are not interchangeable even when the module and the number of teeth are the same. Also, spiral miters require additional consideration since the right-hand mates with the left-hand spiral as shown in the table below.



■ Straight Miter (○ Allowable × Not allowable)

Catalog Number	SMA SMB SMC	MM	SM	SUM	SUMA	PM	DM	LM	SAM
SMA/SMB/SMC	○	○	○	○	○	○	×	×	×
MM	○	○	○	○	○	○	×	×	×
SM	○	○	○	○	○	○	×	×	×
SUM	○	○	○	○	○	○	×	×	×
SUMA	○	○	○	○	○	○	×	×	×
PM	○	○	○	○	○	○	×	×	×
DM	×	×	×	×	×	×	○	×	×
LM	×	×	×	×	×	×	×	○	×
SAM	×	×	×	×	×	×	×	×	○

■ Spiral Miter (○ Allowable × Not allowable)

Catalog Number	Series	MMSGQ	MMSG	SMSG	MMSA MMSB	MMS	SMS
Series	Direction of spiral	R	R	R	R	R	R
MMSGQ	L	○	×	×	×	×	×
MMSG	L	×	○	×	×	×	×
SMSG	L	×	×	○	×	×	×
MMSA/MMSB	L	×	×	×	○	×	×
MMS	L	×	×	×	×	○	×
SMS	L	×	×	×	×	×	○

2. Caution in Selecting Gears Based on Gear Strength

The gear strength values shown in the product pages were computed by assuming the application environment in the table below. Therefore, they should be used as reference only. We recommend that each user computes their own values by applying the actual usage conditions.

■ Calculation of Bending Strength of Gears

Item	Catalog Number	MMSGQ,MMSG MMSA,MMSB MMS,MM	SMSG/SMS SMA/SMB/ SMC	SM SAM	SM-H SAM-H	SUM SUMA LM NOTE 2	PM	DM
Formula NOTE 1	Formula of bevel gears on bending strength (JGMA403-01)						The Lewis formula	
No. of teeth of mating gears	Same no. of teeth						—	
Rotational Speed	100rpm (600rpm for MMSGQ, MMSG and SMSG)						100rpm	
Design Life (Durability)	Over 10 <sup>7</sup> cycles						—	
Impact from motor	Uniform load						Allowable bending stress (kgf/mm <sup>2</sup> )	
Impact from load	Uniform load							
Direction of load	Bidirectional load (calculated with allowable bending stress of 2/3)							
Allowable bending stress at root $\sigma_{rim}$ (kgf/mm <sup>2</sup> )	47	21	19	19	10.5	1.15 (40°C with No Lubrication) m 0.5 4.0 m 0.8 4.0 m 1.0 3.5 m 1.5 1.8 NOTE 2 (40°C with Grease Lubrication)		
Safety factor $K_R$	1.2							

■ Calculation of Surface Durability (Except where it is common with bending strength)

Item	Catalog Number	MMSGQ,MMSG MMSA,MMSB MMS,MM	SMSG/SMS SMA/SMB/ SMC	SM SAM	SM-H SAM-H	SUM SUMA LM NOTE 2	PM	DM
Formula NOTE 1	Formula of bevel gears on surface durability (JGMA404-01)							
Kinematic viscosity of lubricant	100cSt (50°C)							
Gear support	Shafts & gear box have normal stiffness, and gears are supported on one end							
Allowable Hertz stress $\sigma_{Hlim}$ (kgf/mm <sup>2</sup> )	166	90	49	90	41.3			
Safety factor $C_R$	1.15							

[NOTE 1] The gear strength formula is based on JGMA (Japanese Gear Manufacturers Association) specifications, "MC Nylon Technical Data" by Mitsubishi Chemical Advanced Materials and "Duracon (R) Gear" by Polyplastics Co. The units for the rotational speed (rpm) and the stress (kgf/mm<sup>2</sup>) are adjusted to the units needed in the formula.

[NOTE 2] The values of the allowable bending stresses for DM m1.5 gears and the allowable root bending stress for LM gears are our own estimates.

Selecting the Gears

Step 1

Determine the calculated load torque applied to the gear and the gear type suitable for the purpose.

Step 2

Select provisionally from the allowable torque table in this catalog based on the load torque.

■ For provisional selection from this catalog

Catalog Number	No. of teeth	Series	A	B	C	D	E	F	G	H	I	J	K	Allowable torque (kgf-m)	Allowable torque (kgf-m)	Backlash (mm)
MMSG2-20R	12	35	40	42.7	35	21.98	16.35	12.5	20	9	24.54	17.0	23.5	1.73	2.40	0.04-0
MMSG2-20L	14	42	50	53.2	45	28.63	21.6	16	26	11	30.89	32.7	46.1	3.33	4.70	0.05-0
MMSG3-20R	16	52	60	63.99	50	30.78	21.99	16	27	14	34.4	58.5	83.7	5.97	8.54	0.06-0
MMSG3-20L	20	50	70	74.53	55	32.45	22.26	14	29	16	42.75	91.8	133	9.36	13.6	0.07-0
MMSG4-20R	20	55	80	84.99	65	39.13	27.5	17	35	18	49.08	136	199	13.8	20.3	0.09-0
MMSG4-20L	12	38	50	52.5	40	23.43	16.25	11	21	11	30.89	27.5	47.0	2.80	4.79	0.04-0
MMSG2-25R	16	45	62.5	65.54	50	29.57	20.27	14	26	14	37.4	54.3	94.5	5.54	9.64	0.05-0
MMSG2-25L	20	55	75	78.78	60	35.6	24.39	17	31	17	43.92	94.5	167	9.64	17.0	0.06-0
MMSG3-25R	25	65	87.5	91.81	70	41.65	28.41	19	37	20	52.43	151	270	15.4	27.5	0.07-0
MMSG3-25L	28	75	100	104.7	80	47.8	32.35	22	42	23	58.95	216	392	22.1	40.0	0.09-0

Step 3

Calculate the strength under the actual usage conditions.

Calculate the strength formally using the various gear strength formulas. Please see our separate technical reference book for more details. We recommend using the Website that allows the strength to be easily calculated.

■ Use the strength calculation function on our website.

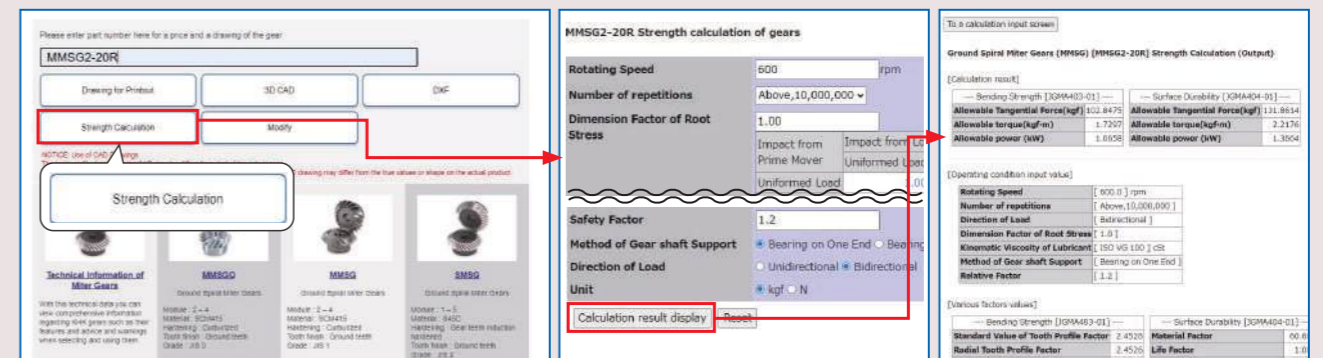

■ Bending strength

Calculated values of the strength at which the gear teeth do not break due to fatigue.

■ Surface durability;

Calculated values of the strength at which the gear teeth do not wear due to surface fatigue damage.

When selecting KHK standard gears, glance over the Product Precautions on page 310 and Cautions on Performing Secondary Operations on each page.

- Products not listed in this catalog or materials, modules, number of teeth and the like not listed in the dimensional tables can be manufactured as custom items. Please see Page 26 for more details about custom-made orders.
- The color and shape of the product images listed on the dimension table page of each product may differ from the actual product. Be sure to confirm the shape in the dimension table before selection.
- The details (specifications, dimensions, etc.) listed in the catalog may be changed without prior notice. Changes are announced on the KHK website.

Website URL: <https://khkgears.net/new/>  
 Overseas Sales Department: Phone: +81-48-254-1744 Fax: +81-48-254-1765 E-mail: [info@khkgears.net](mailto:info@khkgears.net)

**Product Precautions**

**Common Notes**
**[Caution on Product Characteristics]**

- (1) The allowable torque shown in the table are calculated values according to the assumed usage conditions. Please see page 308 for more details.
- (2) The backlash values shown in the table are the theoretical values for the backlash in the normal direction of a pair of identical gears in mesh.
- (3) A set of spiral miter gears must be identical in module and number of teeth, but opposite in spiral hands.
- (4) Dimensions of the outside diameter, the total length and crown to back length are all theoretical values, and some differences will occur due to the corner chamfering of the gear tips.
- (5) These bevel gears produce axial thrust forces. Please see page 312 for more details.
- (6) Variations in temperature or humidity can cause dimensional changes in plastic gears, including tooth diameter, bore, and backlash. The accuracy and tolerances shown in the catalog are values obtained when machining is performed.
- (7) Keyways are made according to JIS B1301 standards, Js9 tolerance. Also note that keyway tooth position alignment is not performed.
- (8) For products having a tapped hole, a set screw is included. (excludes B7)
- (9) See page 22 for more details on Hardened Plus (H Series and HJ Series).
  - KHK's Specifications for Heat Treatment
    - Hardened location: Tooth surface, or Tooth surface and Tooth root
    - Hardness: 50 to 60 HRC
  - \* Hardness and Depth of Gear-teeth Induction Hardening
    - The hardening method and the state of the hardened teeth area vary depending on the size of gears.
    - Since different hardening treatment is applied in accordance with the module and number of teeth, the hardness level is referred to as the hardness of the reference diameter.
    - For some of our products, the hardness at tooth tip / root may not be equal to the hardness you designated.
    - As to the effective case depth, it is specified by JIS, as "The distance from the surface of the case to the area with hardness HV450." The case depth differs from area to area of a tooth, so the depth cannot be specified.
    - Due to the gear teeth being induction hardened, no secondary operations can be performed on tooth areas including the bottom land (approx. 2 to 3 mm).

**[J Series]**

- (1) Certain products which would otherwise have a very long tapped hole are counterbored. For details, please see the KHK website.
- (2) Black oxide is not re-applied to parts undergoing secondary operations.
- (3) For bores over  $\phi$  50, the bore tolerance is H8.

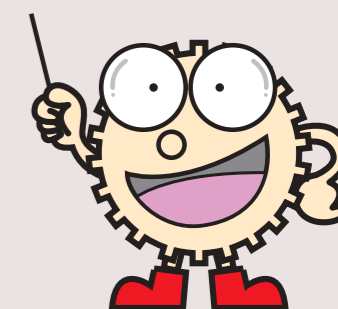
**MEMO**

## Application Hints



In order to use KHK stock miters safely, carefully read the Application Hints before proceeding. If there are questions or you require clarifications, please contact our technical department or your nearest distributor. E-mail: info@khkgears.net  
Please read "Cautions on Performing Secondary Operations" below when performing modifications and/or secondary operations for safety concerns.

### 1. Cautions on Handling

- ① KHK products are packaged one by one to prevent scratches and dents, but if you find issues such as rust, scratches, or dents when the product is removed from the box after purchase, please contact the supplier.
- ② Depending on the handling method, the product may become deformed or damaged. Resin gears and ring gears deform particularly easily, so please handle with care.

### 2. Caution on Performing Secondary Operations

- ① If re-boring, it is important to pay special attention to locating the center in order to avoid runout.
- ② The reference datum for gear machining is the bore. Therefore, use the bore for locating the center. If it is too difficult to do for small bores, the alternative is to use one spot on the bore and the runout of the side surface.
- ③ If reworking using scroll chucks, we recommend the use of new or rebored jaws for improved precision. Please exercise caution not to crush the teeth.

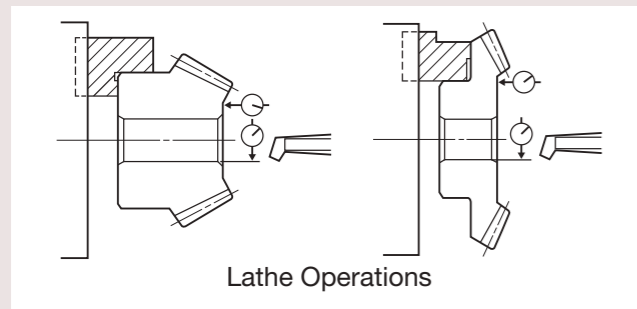

- ④ For items with induction hardened teeth, the hardness is high near the tooth root. When machining the front face, the machined area should be 4 to 6mm smaller than the holding surface diameter dimensions.

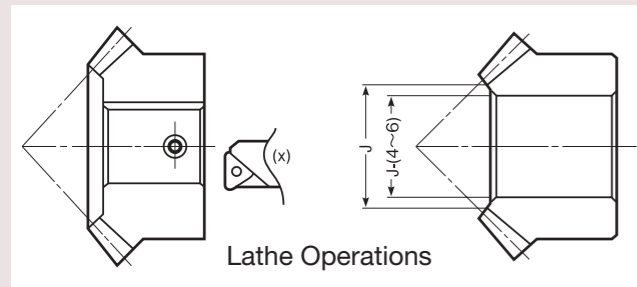

- ⑤ For tapping and keyway operations, see the examples given in "Caution on Performing Secondary Operations" in KHK Stock Spur Gear section. When providing keyway operations, to avoid stress concentration, always round the corners. Make sure that the diameter (O) of the keyway is smaller than the diameter of the holding surface.

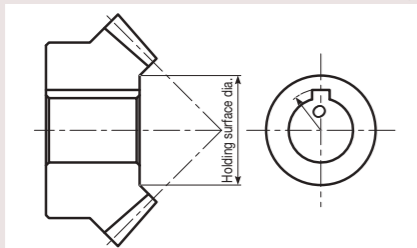

- ⑥ PM plastic miter gears are susceptible to changes due to temperature and humidity. Dimensions may change between, during, and after re-machining operations.
- ⑦ When induction-hardening S45C products, thermal stress cracks may appear. Also, note that the precision grade of the product declines by 1 or 2 grades, as deformation on material may occur. If you require tolerance for bore or other parts, machining is necessary after heat treatment.

### 3. Points of Caution during Assembly

- ① Since miter gears are cone shaped, they produce axial thrust forces. Specifically with regard to spiral miter gears, the directions of thrust change with the hand of helix and the direction of rotation. This is illustrated below. The bearings must be selected properly to be able to handle these thrust forces. For details, use gear calculation software GCSW.

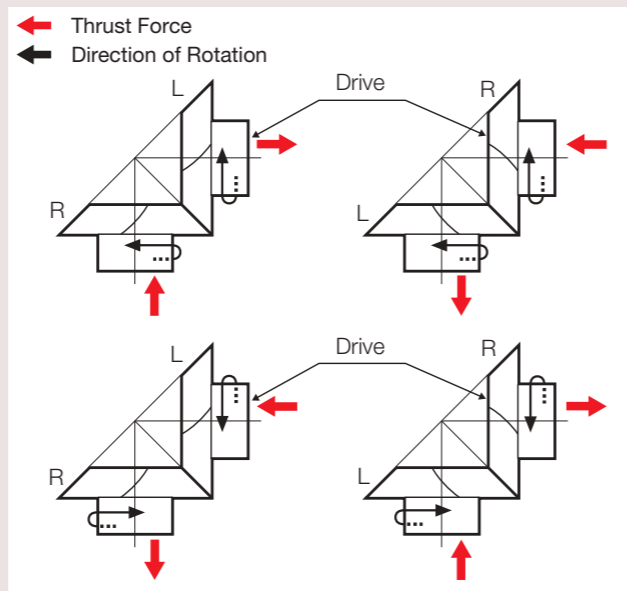

- ② If a gear is mounted on a shaft far from the bearings, the shaft may bend. We recommend designing bevel gears to be as close to the bearings as possible. Design the gear box, shaft and bearing with high rigidity.

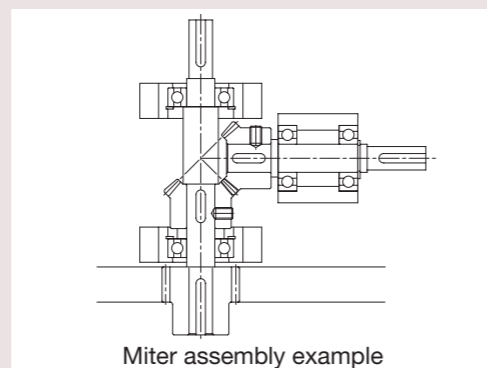

- ③ Be sure to fasten the miter to prevent the gears from moving, as thrust acts on it while rotating.
- ④ When installing MMSA or MMSB finished bore spiral miter gears produced as B7 style (ring gear), always secure the gears onto the mounting base with taper pins to absorb the rotational loads. It is dangerous to secure with bolts only. (See the top of the right page for reference figure)

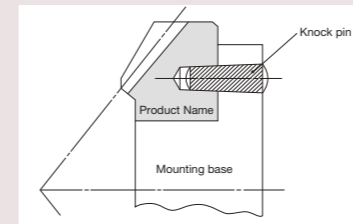

- ⑤ The recommended assemble distance tolerance of KHK stock miters is H7 for ground gears and H8 for cut gears. Mounting distance error, offset error and shaft angle error must be minimized to avoid excessive noise and wear. Inaccurate assembly will lead to irregular noises and uneven wear. Various conditions of tooth contact are shown below. Also, when changing the normal direction backlash, adjust the mounting distance according to the amount of axial movement shown in the table on the right so as not to change the tooth contact.

Shaft angle (°)	Normal direction Backlash	Travel in axial direction	
		Drive gear	Driven gear
90	$j_n$	$1.03 \times j_n$	$1.03 \times j_n$
60		$1.46 \times j_n$	$1.46 \times j_n$
120		$0.84 \times j_n$	$0.84 \times j_n$

### Correct Tooth Contact

- When assembled correctly, the contact will occur on both gears in the middle of the flank and center of face width but somewhat closer to the toe.

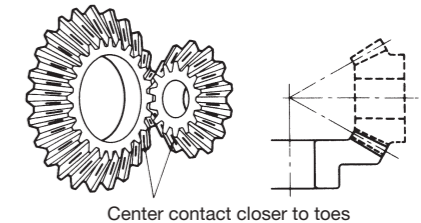

### Incorrect Tooth Contact

#### Mounting Distance Error

- When the mounting distance of the pinion is incorrect, the contact will occur too high on the flank on one gear and too low on the other.

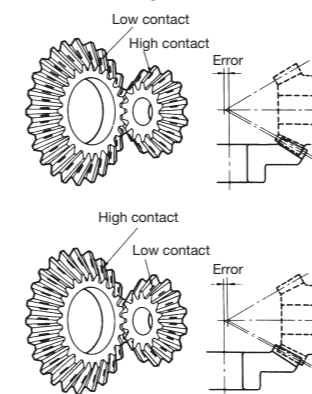

#### Offset Error

- When the pinion shaft is offset, the contact surface is near the toe of one gear and near the heel of the other.

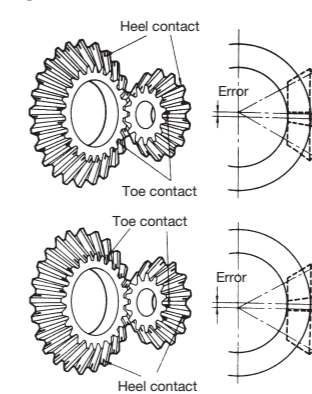

#### Shaft Angle Error

- When there is an angular error of shafts, the gears will contact at the toes or heels depending on whether the angle is greater or less than 90°.

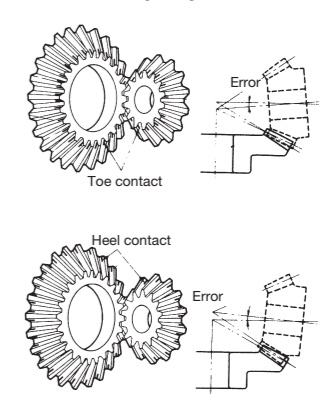

### 4. Cautions on Starting

- ① Check the following items before starting.
  - Are the gears fastened securely?
  - Is there uneven tooth contact?
  - Is there adequate backlash? (Be sure to avoid zero-backlash.)
  - Has proper lubrication been supplied?
- ② If gears are exposed, be sure to attach a safety cover to ensure safety. Also, be careful not to touch rotating gears.
- ③ If there is any abnormality such as noise or vibration during startup, stop the operation immediately and check the assembly condition such as tooth contact, eccentricity and looseness.

KHK considers safety a priority in the use of our products. When handling, adding secondary operations, assembling, and operating KHK products, please be aware of the following issues in order to prevent accidents.

#### Warning: Precautions for preventing physical and property damage

1. When using KHK products, follow relevant safety regulations (Occupational Safety and Health Regulations, etc.).
2. Pay attention to the following items when installing, removing, or performing maintenance and inspection of the product.
  - ① Turn off the power switch.
  - ② Do not reach or crawl under the product.
  - ③ Wear appropriate clothing and protective equipment for the work.

#### Caution: Cautions in Preventing Accidents

1. Before using a KHK product, read the precautions in the catalog carefully in order to use it correctly.
2. Avoid use in environments that may adversely affect the product.
3. Our products are manufactured under a superior quality control system based on the ISO9001 quality management system; if you notice any malfunctions upon purchasing a product, please contact the supplier.



Specifications	
Precision grade	JIS B 1704: 1978 grade 0*
Gear teeth	Gleason
Pressure angle	20°
Helix angle	35°
Material	SCM415
Heat treatment	Carburized **
Tooth hardness	55 to 60HRC

\* The precision grade of J Series products is equivalent to the value shown in the table.  
 \*\* In the illustration, the area surrounded with --- line is masked during the carburization process (max. HRC40 or so) and can be modified.

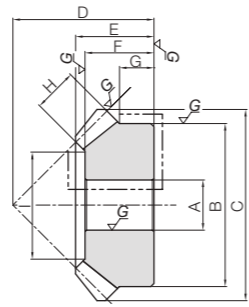

B3

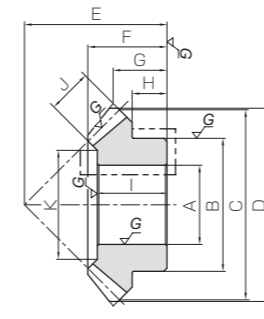

B4

J Series

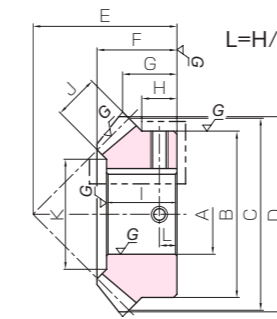

B3K

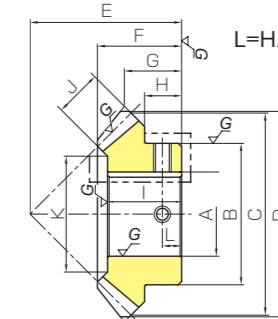

B4K



To order J Series products, please specify: **Catalog No. + J + BORE.**

Catalog Number	Gear Ratio	No. of teeth	Shape	Direction of spiral	Bore		Pitch dia.	Outside dia.	Mounting distance	Total length	Crown to back	Hub width	Hole length	Face width	Holding surface dia.	Allowable torque (N·m)		Allowable torque (kgf·m)		Backlash (mm)	Weight (kg)	
					A-H7	B										Bending strength	Surface durability	Bending strength	Surface durability			
MMSGQ2-20R	1	20	B3	R	12	35	40	40	35	21	16.35	12.5	20	9	24.54	17.0	23.5	1.73	2.40	0~0.05	0.14	
MMSGQ2-20L				L	14	42	50	51	45	28	21.6	16	26	11	30.89	32.7	46.1	3.33	4.70	0.05~0.10	0.27	
MMSGQ2.5-20R				R	16	52	60	61	50	30	21.99	16	27	14	34.4	58.5	83.7	5.97	8.54			
MMSGQ2.5-20L				L	20	50	70	71	55	31.5	22.26	14	29	16	42.75	91.8	133	9.36	13.6			
MMSGQ3-20R				R	20	55	80	81	65	38	27.5	17	35	18	49.08	136	199	13.8	20.3			
MMSGQ3-20L				L	14	45	60	60	50	28.5	21.21	15	26	12	38.06	38.5	78.6	3.93	8.02			0~0.05
MMSGQ3.5-20R			R	16	55	75	76	60	33	24.02	16	30	15	47.57	75.3	156	7.68	16.0	0.05~0.10			0.66
MMSGQ3.5-20L			L	20	65	90	91	70	39.5	26.8	18	36	20	55.43	139	294	14.2	30.0				
MMSGQ4-20R			R	25	80	105	106	80	43.5	29.6	20	40	22	67.77	204	436	20.8	44.5				
MMSGQ4-20L			L	28	90	120	121	90	48	32.35	22	44	25	77.29	303	657	30.9	67.0				
MMSGQ2-30R			R	14	45	60	60	50	28.5	21.21	15	26	12	38.06	38.5	78.6	3.93	8.02		0~0.05	0.36	
MMSGQ2-30L			L	16	55	75	76	60	33	24.02	16	30	15	47.57	75.3	156	7.68	16.0		0.05~0.10	1.11	
MMSGQ2.5-30R	R	20	65	90	91	70	39.5	26.8	18	36	20	55.43	139	294	14.2	30.0						
MMSGQ2.5-30L	L	25	80	105	106	80	43.5	29.6	20	40	22	67.77	204	436	20.8	44.5						
MMSGQ3-30R	R	28	90	120	121	90	48	32.35	22	44	25	77.29	303	657	30.9	67.0						
MMSGQ3-30L	L	14	45	60	60	50	28.5	21.21	15	26	12	38.06	38.5	78.6	3.93	8.02	0~0.05	0.36				
MMSGQ3.5-30R	R	16	55	75	76	60	33	24.02	16	30	15	47.57	75.3	156	7.68	16.0	0.05~0.10	1.75				
MMSGQ3.5-30L	L	20	65	90	91	70	39.5	26.8	18	36	20	55.43	139	294	14.2	30.0						
MMSGQ4-30R	R	25	80	105	106	80	43.5	29.6	20	40	22	67.77	204	436	20.8	44.5						
MMSGQ4-30L	L	28	90	120	121	90	48	32.35	22	44	25	77.29	303	657	30.9	67.0						

Bore H7	* The product shapes of J Series items are identified by background color.																		
	12	14	15	16	17	18	19	20	22	25	28	30	32	35	40	45	50		
Keyway Js9	4x1.8																		
Screw size	4x1.8			5x2.3				6x2.8				8x3.3			10x3.3		12x3.3		14x3.8
Catalog Number	M4			M5				M6			M8			M10					
MMSGQ2-20R J BORE	[Background color grid for J Series products]																		
MMSGQ2-20L J BORE																			
MMSGQ2.5-20R J BORE																			
MMSGQ2.5-20L J BORE																			
MMSGQ3-20R J BORE																			
MMSGQ3-20L J BORE																			
MMSGQ3.5-20R J BORE																			
MMSGQ3.5-20L J BORE																			
MMSGQ4-20R J BORE																			
MMSGQ4-20L J BORE																			
MMSGQ2-30R J BORE																			
MMSGQ2-30L J BORE																			
MMSGQ2.5-30R J BORE																			
MMSGQ2.5-30L J BORE																			
MMSGQ3-30R J BORE																			
MMSGQ3-30L J BORE																			
MMSGQ3.5-30R J BORE																			
MMSGQ3.5-30L J BORE																			
MMSGQ4-30R J BORE																			
MMSGQ4-30L J BORE																			

[Caution on J series] ① Cancellation is not possible for made-to-order products. See page 42 for lead times and allowable order quantities. See page 44 for other precautions.

Product Precautions → Page 310

Precautions for Standard Machined Products → Pages 42~44

**JIS grade 0 Ground bevel gears**  
Custom Gears are also available.

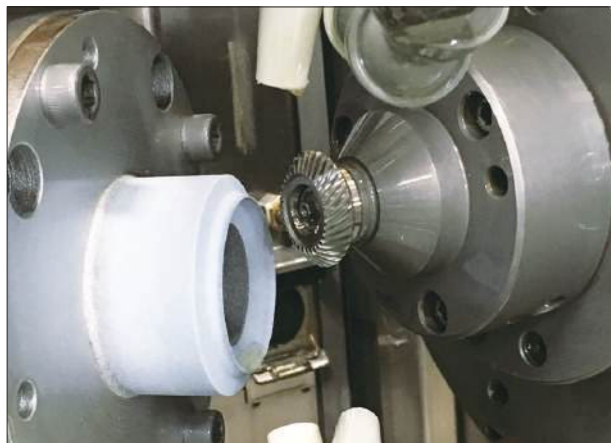

CNC Bevel Gear Grinding Machine (PH-280HG)



Gear Measuring System (350GMS)

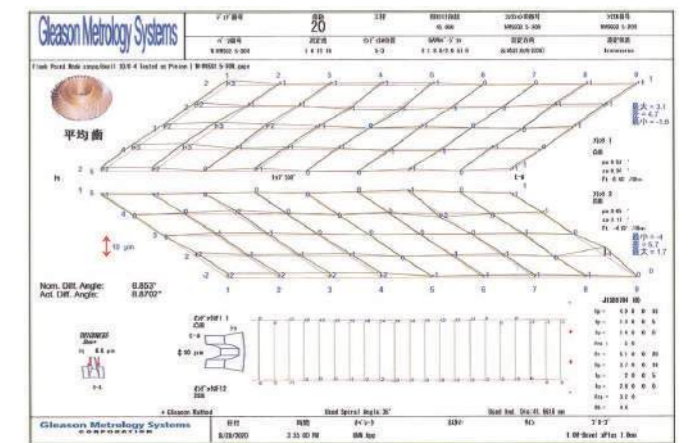

Gear Measurement Data

All machining datum planes are cut and locating the center is made easy to maintain accuracy KHK's highest-grade spiral miter with excellent quietness



Specifications	
Precision grade	JIS B 1704: 1978 grade 1*
Gear teeth	Gleason
Pressure angle	20°
Helix angle	35°
Material	SCM415
Heat treatment	Carburized **
Tooth hardness	55 to 60HRC

\* The precision grade of J Series products is equivalent to the value shown in the table.  
 \*\* In the illustration, the area surrounded with ---- line is masked during the carburization process (max. HRC40 or so) and can be modified.

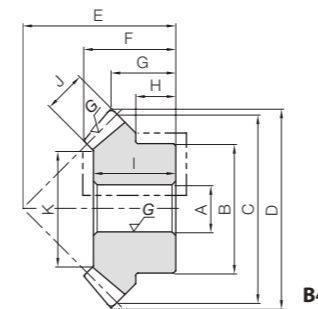
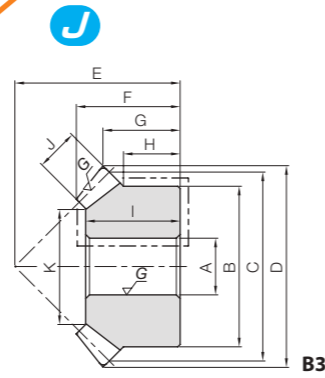

J Series

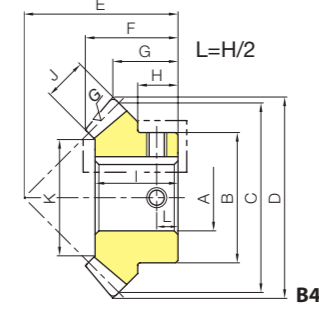
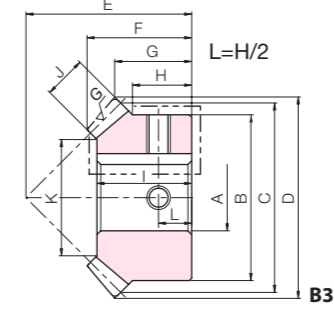

To order J Series products, please specify: **Catalog No. + J + BORE.**

Catalog Number	Gear Ratio	No. of teeth	Shape	Direction of spiral	Bore		Pitch dia.	Outside dia.	Mounting distance	Total length	Crown to back	Hub width	Hole length	Face width	Holding surface dia.	Allowable torque (N·m)		Backlash (mm)	Weight (kg)		
					A-H7	B										Bending strength	Surface durability				
MMSG2-20R MMSG2-20L	1	20	B3	R	12	35	40	42.7	35	21.98	16.35	12.5	20	9	24.54	17.0	23.5	1.73	2.40	0.04~0.10	0.14
MMSG2.5-20R MMSG2.5-20L				L	14	42	50	53.2	45	28.63	21.6	16	26	11	30.89	32.7	46.1	3.33	4.70	0.05~0.11	0.27
MMSG3-20R MMSG3-20L				R	16	52	60	63.99	50	30.78	21.99	16	27	14	34.4	58.5	83.7	5.97	8.54	0.06~0.12	0.43
MMSG3.5-20R MMSG3.5-20L				L	20	50	70	74.53	55	32.45	22.26	14	29	16	42.75	91.8	133	9.36	13.6	0.07~0.13	0.51
MMSG4-20R MMSG4-20L				R	20	55	80	84.99	65	39.13	27.5	17	35	18	49.08	136	199	13.8	20.3	0.09~0.15	0.80
				L																	
MMSG2-25R MMSG2-25L	1	25	B4	R	12	38	50	52.5	40	23.43	16.25	11	21	11	30.89	27.5	47.0	2.80	4.79	0.04~0.10	0.21
MMSG2.5-25R MMSG2.5-25L				L	16	45	62.5	65.54	50	29.57	20.27	14	26	14	37.4	54.3	94.5	5.54	9.64	0.05~0.11	0.37
MMSG3-25R MMSG3-25L				R	20	55	75	78.78	60	35.6	24.39	17	31	17	43.92	94.5	167	9.64	17.0	0.06~0.12	0.65
MMSG3.5-25R MMSG3.5-25L				L	25	65	87.5	91.81	70	41.65	28.41	19	37	20	52.43	151	270	15.4	27.5	0.07~0.13	1.04
MMSG4-25R MMSG4-25L				R	28	75	100	104.7	80	47.8	32.35	22	42	23	58.95	216	392	22.1	40.0	0.09~0.15	1.57
				L																	
MMSG2-30R MMSG2-30L	1	30	B4	R	14	45	60	62.42	50	29.27	21.21	15	26	12	38.06	38.5	78.6	3.93	8.02	0.04~0.10	0.36
MMSG2.5-30R MMSG2.5-30L				L	16	55	75	78.04	60	34.08	24.02	16	30	15	47.57	75.3	156	7.68	16.0	0.05~0.11	0.66
MMSG3-30R MMSG3-30L				R	20	65	90	93.61	70	40.25	26.8	18	36	20	55.43	139	294	14.2	30.0	0.06~0.12	1.11
MMSG3.5-30R MMSG3.5-30L				L	25	80	105	109.21	80	44.4	29.6	20	40	22	67.77	204	436	20.8	44.5	0.07~0.13	1.75
MMSG4-30R MMSG4-30L				R	28	90	120	124.7	90	49.27	32.35	22	44	25	77.29	303	657	30.9	67.0	0.09~0.15	2.49
				L																	

Catalog Number	* The product shapes of J Series items are identified by background color.																
	12	14	15	16	17	18	19	20	22	25	28	30	32	35	40	45	50
MMSG2-20R J BORE																	
MMSG2-20L J BORE																	
MMSG2.5-20R J BORE																	
MMSG2.5-20L J BORE																	
MMSG3-20R J BORE																	
MMSG3-20L J BORE																	
MMSG3.5-20R J BORE																	
MMSG3.5-20L J BORE																	
MMSG4-20R J BORE																	
MMSG4-20L J BORE																	
MMSG2-25R J BORE																	
MMSG2-25L J BORE																	
MMSG2.5-25R J BORE																	
MMSG2.5-25L J BORE																	
MMSG3-25R J BORE																	
MMSG3-25L J BORE																	
MMSG3.5-25R J BORE																	
MMSG3.5-25L J BORE																	
MMSG4-25R J BORE																	
MMSG4-25L J BORE																	
MMSG2-30R J BORE																	
MMSG2-30L J BORE																	
MMSG2.5-30R J BORE																	
MMSG2.5-30L J BORE																	
MMSG3-30R J BORE																	
MMSG3-30L J BORE																	
MMSG3.5-30R J BORE																	
MMSG3.5-30L J BORE																	
MMSG4-30R J BORE																	
MMSG4-30L J BORE																	

[Caution on J series] ① Cancellation is not possible for made-to-order products. See page 42 for lead times and allowable order quantities. See page 44 for other precautions.

Spur Gears  
Helical Gears  
Internal Gears  
Racks  
CP Racks & Pinions  
Miter Gears  
Bevel Gears  
Screw Gears  
Worm Gears  
Gearboxes  
Other Products

Spur Gears  
Helical Gears  
Internal Gears  
Racks  
CP Racks & Pinions  
Miter Gears  
Bevel Gears  
Screw Gears  
Worm Gears  
Gearboxes  
Other Products



Specifications	
Precision grade	JIS B 1704: 1978 grade 2*
Gear teeth	Gleason
Pressure angle	20°
Helix angle	35°
Material	S45C
Heat treatment	Gear teeth induction hardened **
Tooth hardness	50 to 60HRC
Surface treatment	Black oxide coated except for teeth

\* The precision grade of J Series products is equivalent to the value shown in the table.  
 \*\* Due to the gear teeth being induction hardened, no secondary operations can be performed on tooth areas including the bottom land (approx. 2 to 3 mm).

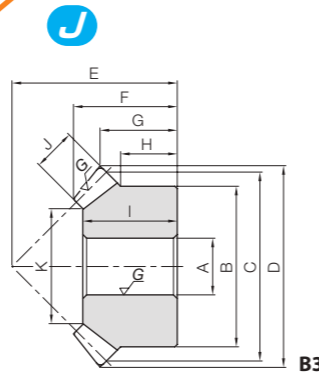

J Series

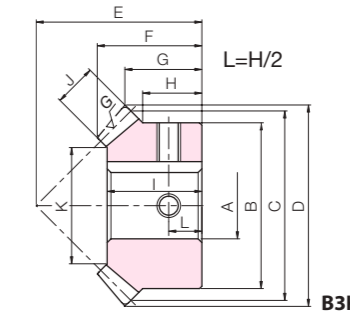
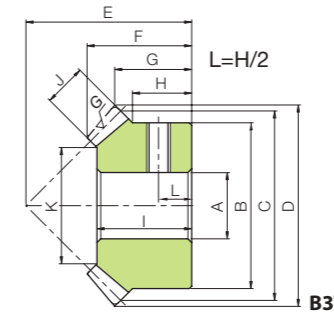

To order J Series products, please specify: **Catalog No. + J + BORE.**

Catalog Number	Gear Ratio	No. of teeth	Shape	Direction of spiral	Bore		Pitch dia.	Outside dia.	Mounting distance	Total length	Crown to back	Hub width	Hole length	Face width	Holding surface dia.	Allowable torque (N·m)		Allowable torque (kgf·m)		Backlash (mm)	Weight (kg)				
					A-H7	B										Bending strength	Surface durability	Bending strength	Surface durability						
SMSG1-20R SMSG1-20L	1	20	B3	R L	6	16	20	21.30	20	13.84	10.65	8	12	5	9.86	1.17	0.97	0.12	0.099	0.02~0.08	0.019				
SMSG1.5-20R SMSG1.5-20L					8	26	30	31.74	30	21.18	15.87	13	19	8	15.37	4.10	3.47	0.42	0.35	0.04~0.10	0.074				
SMSG2-20R SMSG2-20L					12	34	40	42.4	37	24.75	18.2	14	22	10	21.72	7.83	6.79	0.80	0.69	0.05~0.11	0.15				
SMSG2.5-20R SMSG2.5-20L					14	42	50	52.94	48	32.42	24.47	19	29	12	28.06	14.9	13.2	1.52	1.35	0.06~0.12	0.30				
SMSG3-20R SMSG3-20L					16	50	60	63.72	58	39.6	29.86	23	35	15	31.57	26.4	23.7	2.69	2.42	0.07~0.13	0.52				
SMSG3.5-20R SMSG3.5-20L					20	60	70	74.47	65	43.81	32.23	25	40	18	39.09	42.6	38.8	4.35	3.96	0.08~0.14	0.82				
SMSG4-20R SMSG4-20L					20	64	80	84.88	75	50.51	37.44	27	45	20	43.43	62.6	57.8	6.39	5.90	0.10~0.16	1.15				
SMSG1-25R SMSG1-25L					1	25	B3	R L	6	20	25	26.22	23	15.08	11.11	8	14	6	15.03	1.88	1.91	0.19	0.19	0.02~0.08	0.035
SMSG1.5-25R SMSG1.5-25L									10	30	37.5	39.31	34	22.14	16.16	11.5	19	9	19.54	5.29	5.52	0.54	0.56	0.04~0.10	0.11
SMSG2-25R SMSG2-25L									12	40	50	52.4	40	24.19	16.2	10	20	12	26.06	12.6	13.5	1.28	1.37	0.05~0.11	0.21
SMSG2.5-25R SMSG2.5-25L									16	50	62.5	65.54	50	30.24	20.27	12.5	26	15	34.57	24.5	26.8	2.50	2.74	0.06~0.12	0.42
SMSG3-30R SMSG3-30L									20	70	90	93.61	75	45.25	31.8	20	40	20	53.43	60.3	80.4	6.15	8.20	0.07~0.13	1.32
SMSG3.5-30R SMSG3.5-30L									25	90	105	109.21	85	49.4	34.6	25	45	22	67.77	85.1	115	8.68	11.8	0.08~0.14	2.19
SMSG4-30R SMSG4-30L					28	100	120	124.71	95	54.28	37.35	25	50	25	79.29	127	174	12.9	17.8	0.10~0.16	3.07				

Bore H7	* The product shapes of J Series items are identified by background color.																				
	6	8	10	12	14	15	16	17	18	19	20	22	25	28	30	32	35	40	45	50	
Keyway JS9	-																				
Screw size	4 × 1.8			5 × 2.3			6 × 2.8			8 × 3.3			10 × 3.3			12 × 3.3			14 × 3.8		
Catalog Number	M4	M5	M4			M5			M6			M8			M10						
SMSG1-20R J BORE	Green																				
SMSG1-20L J BORE	Green																				
SMSG1.5-20R J BORE		Green	Pink																		
SMSG1.5-20L J BORE		Green	Pink																		
SMSG2-20R J BORE				Pink	Pink	Pink	Pink	Pink													
SMSG2-20L J BORE				Pink	Pink	Pink	Pink	Pink													
SMSG2.5-20R J BORE					Pink	Pink	Pink	Pink	Pink	Pink											
SMSG2.5-20L J BORE					Pink	Pink	Pink	Pink	Pink	Pink											
SMSG3-20R J BORE						Pink	Pink	Pink	Pink	Pink	Pink										
SMSG3-20L J BORE						Pink	Pink	Pink	Pink	Pink	Pink										
SMSG3.5-20R J BORE							Pink	Pink	Pink	Pink	Pink	Pink									
SMSG3.5-20L J BORE							Pink	Pink	Pink	Pink	Pink	Pink									
SMSG4-20R J BORE								Pink	Pink	Pink	Pink	Pink	Pink								
SMSG4-20L J BORE								Pink	Pink	Pink	Pink	Pink	Pink								
SMSG1-25R J BORE	Green	Green																			
SMSG1-25L J BORE	Green	Green																			
SMSG1.5-25R J BORE			Pink	Pink	Pink	Pink	Pink														
SMSG1.5-25L J BORE			Pink	Pink	Pink	Pink	Pink														
SMSG2-25R J BORE				Pink	Pink	Pink	Pink	Pink	Pink												
SMSG2-25L J BORE				Pink	Pink	Pink	Pink	Pink	Pink												
SMSG2.5-25R J BORE					Pink	Pink	Pink	Pink	Pink	Pink											
SMSG2.5-25L J BORE					Pink	Pink	Pink	Pink	Pink	Pink											
SMSG3-30R J BORE								Pink	Pink	Pink	Pink	Pink	Pink								
SMSG3-30L J BORE								Pink	Pink	Pink	Pink	Pink	Pink								
SMSG3.5-30R J BORE									Pink	Pink	Pink	Pink	Pink	Pink	Pink						
SMSG3.5-30L J BORE									Pink	Pink	Pink	Pink	Pink	Pink	Pink						
SMSG4-30R J BORE										Pink	Pink	Pink	Pink	Pink	Pink	Pink					
SMSG4-30L J BORE										Pink	Pink	Pink	Pink	Pink	Pink	Pink					

[Caution on J series] ① Cancellation is not possible for made-to-order products. See page 42 for lead times and allowable order quantities. See page 44 for other precautions.

Spur Gears  
Helical Gears  
Internal Gears  
Racks  
CP Racks & Pinions  
Miter Gears  
Bevel Gears  
Screw Gears  
Worm Gears  
Gearboxes  
Other Products

Spur Gears  
Helical Gears  
Internal Gears  
Racks  
CP Racks & Pinions  
Miter Gears  
Bevel Gears  
Screw Gears  
Worm Gears  
Gearboxes  
Other Products



Specifications	
Precision grade	JIS B 1704: 1978 grade 4
Gear teeth	Gleason
Pressure angle	20°
Helix angle	35°
Material	SCM415
Heat treatment	Carburized *
Tooth hardness	55 to 60HRC

\* No secondary operations can be performed on these finished gears due to the applied carburizing process.

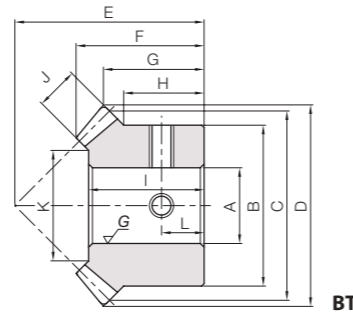

BT

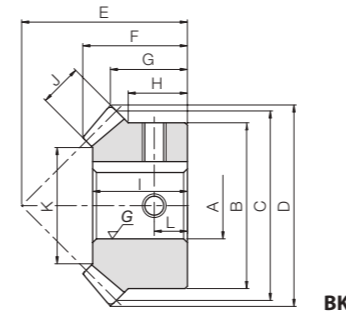

BK

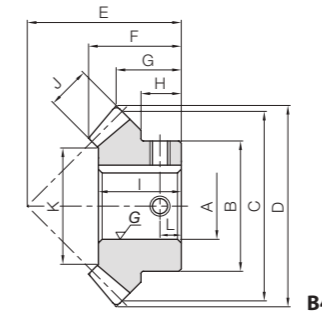

B4

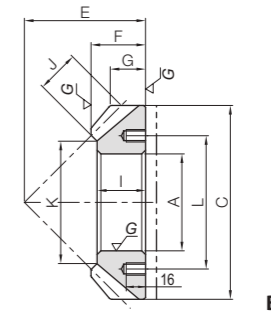

B7

Catalog Number	Gear Ratio	Module	No. of teeth	Direction of spiral	Shape	Bore	Hub dia.	Pitch dia.	Outside dia.	Mounting distance	Total length	Crown to back	Hub width	Hole length
						A <sub>H7</sub>	B	C	D	E	F	G	H	I
MMSA1-20R MMSB1-20R MMSA1-20L MMSB1-20L	1	m1	20	R	BT	8 10	17	20	21.29	20	13.53	10.64	8.5	12.2
L				BT	8 10									
MMSA1.5-20R MMSB1.5-20R MMSA1.5-20L MMSB1.5-20L		m1.5	R	BT BK	10 12	25	30	31.9	28	18.48	13.95	10.5	16.5	
L			BT BK	10 12										
MMSA2-20R MMSB2-20R MMSA2-20L MMSB2-20L		m2	R	BT BK	14 16	35	40	42.52	35	22.09	16.26	12.5	20	
L			14 16											
MMSA2.5-20R MMSB2.5-20R MMSA2.5-20L MMSB2.5-20L		m2.5	R	BK	18 20	42	50	53.2	45	28.63	21.6	16	26	
L			18 20											
MMSA3-20R MMSB3-20R MMSA3-20L MMSB3-20L		m3	R	BK	20 22	52	60	63.99	50	30.78	21.99	16	27	
L			20 22											
MMSA3.5-20R MMSB3.5-20R MMSA3.5-20L MMSB3.5-20L		m3.5	R	BK	25 28	50	70	74.53	55	32.45	22.26	14	29	
L			25 28											
MMSA4-20R MMSB4-20R MMSA4-20L MMSB4-20L		m4	R	B4	28 30	55	80	84.99	65	39.13	27.5	17	35	
L			28 30											
MMSA5-20R MMSB5-20R MMSA5-20L MMSB5-20L		m5	R	B4	30 35	70	100	106.25	75	42.99	28.13	17	38	
L			30 35											
MMSA6-20R MMSB6-20R MMSA6-20L MMSB6-20L		m6	R	B4	40 45	80	120	127.59	90	51.13	33.8	20	45	
L			40 45											
MMSA8-20R MMSA8-20L		m8	R	B7	80	—	160	—	100	45	29.16	—	40	
L			80											
MMSA10-20R MMSA10-20L	m10	R	B7	100	—	200	—	125	58	36.48	—	50		
L		100												

[Caution on Product Characteristics] ① The keyway tolerance is the value before hardening.

Face width	Holding surface dia.	Keyway Width × Depth	Socket head screw Size	Allowable torque (N·m)		Allowable torque (kgf·m)		Backlash (mm)	Weight (kg)	Catalog Number
				Bending strength	Surface durability	Bending strength	Surface durability			
J	K		L							
4.5	11.67	—	4.5	2.24	2.09	0.23	0.21	0.03~0.13	0.018 0.015	MMSA1-20R MMSB1-20R MMSA1-20L MMSB1-20L
7	17.2	4 x 1.8 — 4 x 1.8	2-M4	6	7.74	7.34	0.79	0.75	0.057 0.052	MMSA1.5-20R MMSB1.5-20R MMSA1.5-20L MMSB1.5-20L
9	24.54	5 x 2.3	—	7	18.0	17.3	1.83	1.76	0.13 0.12	MMSA2-20R MMSB2-20R MMSA2-20L MMSB2-20L
11	30.89	—	—	—	34.6	33.7	3.52	3.44	0.24 0.23	MMSA2.5-20R MMSB2.5-20R MMSA2.5-20L MMSB2.5-20L
14	34.4	6 x 2.8	2-M5	8	61.9	61.1	6.32	6.23	0.40 0.39	MMSA3-20R MMSB3-20R MMSA3-20L MMSB3-20L
16	42.75	—	—	—	97.1	96.7	9.90	9.86	0.46 0.43	MMSA3.5-20R MMSB3.5-20R MMSA3.5-20L MMSB3.5-20L
18	49.08	8 x 3.3	2-M6	9	144	144	14.6	14.7	0.70 0.68	MMSA4-20R MMSB4-20R MMSA4-20L MMSB4-20L
23	60.95	8 x 3.3 10 x 3.3	2-M6 2-M8	—	284	288	29.0	29.4	1.32 1.25	MMSA5-20R MMSB5-20R MMSA5-20L MMSB5-20L
27	73.63	12 x 3.3 14 x 3.8	2-M8 2-M10	10	475	496	48.4	50.6	2.11 1.99	MMSA6-20R MMSB6-20R MMSA6-20L MMSB6-20L
35	101	—	—	—	110	1170	111	119	3.98 3.98	MMSA8-20R MMSA8-20L
45	122.72	—	6-M10	—	130	1660	169	188	7.88 7.88	MMSA10-20R MMSA10-20L

When installing products produced in B7 style (ring type), always secure the gears onto the mounting base with taper pins to absorb the rotational loads. It is dangerous to secure with bolts only.

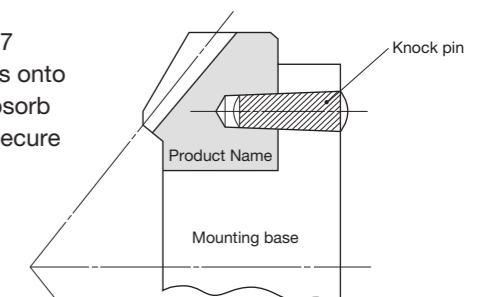



Specifications	
Precision grade	JIS B 1704: 1978 grade 4
Gear teeth	Gleason
Pressure angle	20°
Helix angle	35°
Material	SCM415
Heat treatment	Carburized *
Tooth hardness	55 to 60HRC
Surface treatment	Black oxide coating

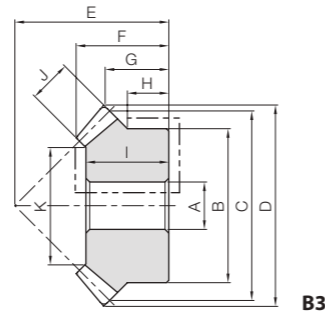

\* In the illustration, the area surrounded with ---- line is masked during the carburization process (max. HRC40 or so) and can be modified.

Catalog Number	Gear Ratio	Module	No. of teeth	Direction of spiral	Shape	Bore		Hub dia.	Pitch dia.	Outside dia.	Mounting distance	Total length	Crown to back
						A <sub>H7</sub>	B	C	D	E	F	G	
MMS2-20R MMS2-20L	1	m2	20	R L	B3	12	34	40	42.31	35	22.14	16.15	
MMS2.5-20R MMS2.5-20L		m2.5		R L		15	42	50	53.2	45	28.63	21.6	
MMS3-20R MMS3-20L		m3		R L		16	52	60	63.99	50	30.78	21.99	
MMS4-20R MMS4-20L		m4		R L		20	65	80	84.99	65	39.13	27.5	
MMS5-20R MMS5-20L		m5		R L		25	85	100	106.25	75	42.99	28.13	
MMS2-25R MMS2-25L	1	m2	25	R L	B3	12	45	50	52.4	40	24.19	16.2	
MMS2.5-25R MMS2.5-25L		m2.5		R L		16	55	62.5	65.54	50	30.24	20.27	
MMS3-25R MMS3-25L		m3		R L		20	65	75	78.77	60	37.57	24.39	
MMS4-25R MMS4-25L		m4		R L		25	85	100	104.7	80	49.14	32.35	
MMS5-25R MMS5-25L		m5		R L		28	100	125	130.86	100	60.59	40.43	
MMS4-30R MMS4-30L	1	m4	30	R L	B3	28	100	120	124.71	95	54.28	37.35	
MMS5-30R MMS5-30L		m5		R L		28	130	150	155.9	120	68.2	47.95	

Hub width	Hole length	Face width	Holding surface dia.	Allowable torque (N·m)		Allowable torque (kgf·m)		Backlash (mm)	Weight (kg)	Catalog Number
				Bending strength	Surface durability	Bending strength	Surface durability			
H	I	J	K							
12	20	9	24.54	17.0	17.3	1.73	1.76	0.06~0.16	0.13	MMS2-20R MMS2-20L
16	26	11	30.89	32.7	33.7	3.34	3.44	0.07~0.17	0.26	MMS2.5-20R MMS2.5-20L
16	27	14	34.4	58.7	61.1	5.98	6.23	0.08~0.18	0.43	MMS3-20R MMS3-20L
17.5	35	18	49.08	136	144	13.9	14.7	0.12~0.27	0.92	MMS4-20R MMS4-20L
17.5	38	23	60.95	269	288	27.5	29.4	0.14~0.34	1.65	MMS5-20R MMS5-20L
12.5	21	12	28.06	29.1	36.3	2.96	3.70	0.06~0.16	0.25	MMS2-25R MMS2-25L
15	27	15	36.57	56.7	71.8	5.79	7.32	0.07~0.17	0.47	MMS2.5-25R MMS2.5-25L
17.5	33	20	39.43	104	133	10.6	13.6	0.08~0.18	0.81	MMS3-25R MMS3-25L
22.5	44	25	57.29	238	309	24.3	31.5	0.12~0.27	1.88	MMS4-25R MMS4-25L
25	50	30	65.15	454	595	46.3	60.7	0.14~0.34	3.39	MMS5-25R MMS5-25L
25	50	25	79.29	348	488	35.5	49.8	0.12~0.27	3.07	MMS4-30R MMS4-30L
35	62	30	99.15	662	941	67.5	96.0	0.14~0.34	6.44	MMS5-30R MMS5-30L

Spur Gears  
 Helical Gears  
 Internal Gears  
 Racks  
 CP Racks & Pinions  
 Miter Gears  
 Bevel Gears  
 Screw Gears  
 Worm Gears  
 Gearboxes  
 Other Products

Spur Gears  
 Helical Gears  
 Internal Gears  
 Racks  
 CP Racks & Pinions  
 Miter Gears  
 Bevel Gears  
 Screw Gears  
 Worm Gears  
 Gearboxes  
 Other Products



Specifications	
Precision grade	JIS B 1704: 1978 grade 4
Gear teeth	Gleason
Pressure angle	20°
Helix angle	35°
Material	S45C
Heat treatment	Gear teeth induction hardened
Tooth hardness	50 to 60HRC
Surface treatment	Black oxide coating

\* The precision grade of J Series products is equivalent to the value shown in the table.

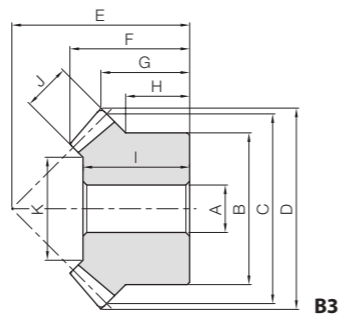

J Series

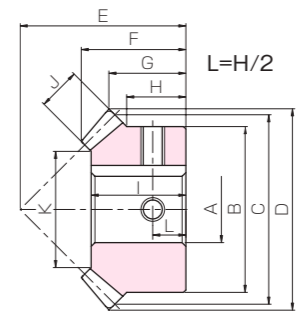
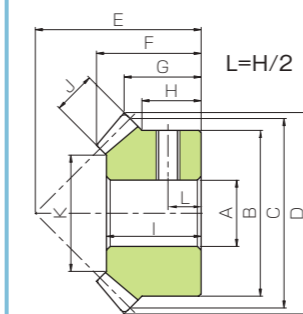

To order J Series products, please specify: **Catalog No. + J + BORE.**

Catalog Number	Gear Ratio	No. of teeth	Shape	Direction of spiral	Bore											Allowable torque (N·m)				Backlash (mm)	Weight (kg)
					A-H7	B	C	D	E	F	G	H	I	J	K	Bending strength	Surface durability	Bending strength	Surface durability		
SMS1-20R SMS1-20L	1	20	B3	R	6	16	20	21.3	20	13.84	10.65	8	12	5	9.86	1.07	0.65	0.11	0.067	0.03~0.13	0.019
SMS1.5-20R SMS1.5-20L				R	8	26	30	31.74	30	21.18	15.87	13	19	8	15.37	3.73	2.33	0.38	0.24	0.05~0.15	0.074
SMS2-20R SMS2-20L				R	12	34	40	42.4	37	24.75	18.2	14	22	10	21.72	8.54	5.40	0.87	0.55	0.06~0.16	0.15
SMS2.5-20R SMS2.5-20L				R	14	42	50	52.94	48	32.42	24.47	19	29	12	28.06	16.3	10.5	1.66	1.07	0.07~0.17	0.30
SMS3-20R SMS3-20L				R	16	50	60	63.72	58	39.6	29.86	23	35	15	31.57	28.8	18.7	2.94	1.91	0.08~0.18	0.52
SMS3.5-20R SMS3.5-20L				R	20	60	70	74.47	65	43.81	32.23	25	40	18	39.09	46.5	30.4	4.74	3.10	0.10~0.25	0.82
SMS4-20R SMS4-20L				R	20	64	80	84.88	75	50.51	37.44	27	45	20	43.43	68.3	45.0	6.97	4.59	0.12~0.27	1.15
SMS5-20R SMS5-20L				R	25	80	100	105.9	90	60.16	42.95	30	54	26	54.46	136	90.9	13.9	9.27	0.14~0.34	2.13
SMS6-20R SMS6-20L				R	28	100	120	127.16	104	67.35	47.58	34	60	30	67.15	226	155	23.0	15.8	0.16~0.36	3.65
SMS8-20R SMS8-20L				R	30	130	160	169.94	125	72.6	49.97	30	62	35	95	484	344	49.4	35.1	0.20~0.45	7.00
SMS1-25R SMS1-25L				R	6	20	25	26.22	23	15.08	11.11	8	14	6	15.03	1.71	1.28	0.17	0.13	0.03~0.13	0.035
SMS1.5-25R SMS1.5-25L				R	10	30	37.5	39.31	34	22.14	16.16	11.5	19	9	19.54	5.78	4.42	0.59	0.45	0.05~0.15	0.11
SMS2-25R SMS2-25L				R	12	40	50	52.38	40	24.2	16.19	10	20	12	26.06	13.7	10.7	1.40	1.09	0.06~0.16	0.21
SMS2.5-25R SMS2.5-25L				R	16	50	62.5	65.54	50	30.24	20.27	12.5	26	15	34.57	26.8	21.1	2.73	2.15	0.07~0.17	0.42
SMS3-25R SMS3-25L				R	20	60	75	78.77	60	37.57	24.39	15	32	20	37.43	49.1	39.1	5.00	3.98	0.08~0.18	0.74
SMS3.5-25R SMS3.5-25L				R	25	70	87.5	91.81	70	42.98	28.41	17.5	37	22	46.77	75.4	60.6	7.69	6.18	0.10~0.25	1.14
SMS4-25R SMS4-25L	R	28	80	100	104.7	80	49.14	32.35	20	43	25	55.29	112	90.7	11.5	9.25	0.12~0.27	1.71			
SMS5-25R SMS5-25L	R	28	100	125	130.86	100	60.59	40.43	25	50	30	65.15	214	175	21.8	17.8	0.14~0.34	3.39			
SMS6-25R SMS6-25L	R	28	120	150	157.17	120	71.97	48.58	30	61	35	83	357	300	36.4	30.6	0.16~0.36	5.99			
SMS2-30R SMS2-30L	R	12	45	60	62.42	50	29.27	21.21	12.5	25	12	36.06	18.2	16.9	1.86	1.72	0.06~0.16	0.37			
SMS2.5-30R SMS2.5-30L	R	16	60	75	78.04	62	36.08	26.02	17	32	15	47.57	35.6	33.4	3.63	3.40	0.07~0.17	0.76			
SMS3-30R SMS3-30L	R	20	70	90	93.61	75	45.25	31.8	20	40	20	53.43	65.8	62.3	6.71	6.35	0.08~0.18	1.32			
SMS3.5-30R SMS3.5-30L	R	25	90	105	109.21	85	49.4	34.6	25	45	22	67.77	101	96.0	10.3	9.79	0.10~0.25	2.19			
SMS4-30R SMS4-30L	R	28	100	120	124.71	95	54.28	37.35	25	50	25	79.29	150	144	15.3	14.7	0.12~0.27	3.07			
SMS5-30R SMS5-30L	R	28	130	150	155.90	120	68.2	47.95	35	62	30	99.15	284	276	29.0	28.1	0.14~0.34	6.44			

[Caution on Product Characteristics] ① The bore may slightly vary due to the effect of heat treatment. When using with the listed bore diameter, you may need to ream the bore prior to use.

Keyway J <sub>S9</sub>	* The product shapes of J Series items are identified by background color.																								
	8	10	12	14	15	16	17	18	19	20	22	25	28	30	32	35	40	45	50	55	60	65	70	75	80
SMS1-20R J BORE SMS1-20L J BORE																									
SMS1.5-20R J BORE SMS1.5-20L J BORE																									
SMS2-20R J BORE SMS2-20L J BORE																									
SMS2.5-20R J BORE SMS2.5-20L J BORE																									
SMS3-20R J BORE SMS3-20L J BORE																									
SMS3.5-20R J BORE SMS3.5-20L J BORE																									
SMS4-20R J BORE SMS4-20L J BORE																									
SMS5-20R J BORE SMS5-20L J BORE																									
SMS6-20R J BORE SMS6-20L J BORE																									
SMS8-20R J BORE SMS8-20L J BORE																									
SMS1-25R J BORE SMS1-25L J BORE																									
SMS1.5-25R J BORE SMS1.5-25L J BORE																									
SMS2-25R J BORE SMS2-25L J BORE																									
SMS2.5-25R J BORE SMS2.5-25L J BORE																									
SMS3-25R J BORE SMS3-25L J BORE																									
SMS3.5-25R J BORE SMS3.5-25L J BORE																									
SMS4-25R J BORE SMS4-25L J BORE																									
SMS5-25R J BORE SMS5-25L J BORE																									
SMS6-25R J BORE SMS6-25L J BORE																									
SMS2-30R J BORE SMS2-30L J BORE																									
SMS2.5-30R J BORE SMS2.5-30L J BORE																									
SMS3-30R J BORE SMS3-30L J BORE																									
SMS3.5-30R J BORE SMS3.5-30L J BORE																									
SMS4-30R J BORE SMS4-30L J BORE																									
SMS5-30R J BORE SMS5-30L J BORE																									

[Caution on J series] ① Cancellation is not possible for made-to-order products. See page 42 for lead times and allowable order quantities. See page 44 for other precautions.



Specifications	
Precision grade	JIS B 1704: 1978 grade 4
Gear teeth	Gleason
Pressure angle	20°
Helix angle	—
Material	S45C
Heat treatment	Gear teeth induction hardened *
Tooth hardness	50 to 60HRC
Surface treatment	Black oxide coating

\* Due to the gear teeth being induction hardened, no secondary operations can be performed on tooth areas including the bottom land (approx. 2 to 3 mm).

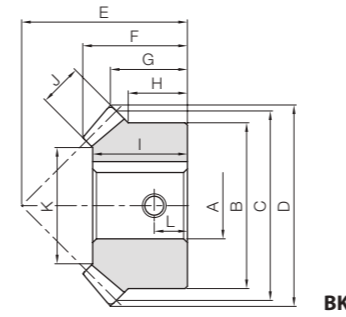
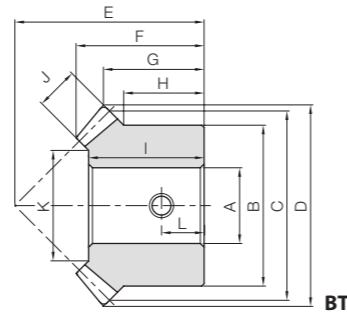

Catalog Number	Gear Ratio	Module	No. of teeth	Shape	Bore	Hub dia.	Pitch dia.	Outside dia.	Mounting distance	Total length	Crown to back	Hub width	Hole length	
					A <sub>H7</sub>	B	C	D	E	F	G	H	I	
SMA1-20 SMB1-20	1	m1	20	BT	8	16	20	21.41	20	13.95	10.71	8	12	
10					26	30	32.12	30	21.24	16.06	13	19		
SMA1.5-20 SMB1.5-20		m1.5		BK	14	34	40	42.83	37	24.89	18.41	14	22	
15					42	50	53.54	48	32.54	24.77	19	29		
SMA2-20 SMB2-20		m2		BK	20	22	50	60	64.24	58	39.84	30.12	23	35
25						60	70	74.24	68	47.84	38.12	26	42	
SMA2.5-20 SMB2.5-20		m2.5		BK	20	30	64	80	85.65	75	50.78	37.83	27	45
32						80	100	107.07	90	60.38	43.54	30	54	
SMA3-20 SMB3-20 SMC3-20		m3		BK	20	40	80	100	107.07	90	60.38	43.54	30	54
30						80	100	107.07	90	60.38	43.54	30	54	
SMA4-20 SMB4-20 SMC4-20	m4	BK	20	30	64	80	85.65	75	50.78	37.83	27	45		
32				80	100	107.07	90	60.38	43.54	30	54			
SMA5-20 SMB5-20 SMC5-20	m5	BK	20	40	80	100	107.07	90	60.38	43.54	30	54		
30				80	100	107.07	90	60.38	43.54	30	54			
SMA1-25	1	m1	25	BT	10	20	25	26.41	23	15.16	11.21	8	14	
SMA1.5-25					m1.5	12	30	37.5	39.62	34	22.25	16.31	11.5	19
SMA2-25 SMB2-25		m2		18		40	50	52.83	40	24.33	16.41	10	20	
15				50	62.5	66.04	50	30.41	20.52	12.5	26			
SMA2.5-25 SMB2.5-25		m2.5		BK	20	50	62.5	66.04	50	30.41	20.52	12.5	26	
18					60	75	79.24	60	37.81	24.62	15	32		
SMA3-25 SMB3-25		m3		BK	25	30	60	75	79.24	60	37.81	24.62	15	32
25						75	90	96.24	75	44.81	27.62	18	39	
SMA4-25 SMB4-25		m4		BK	25	35	80	100	105.66	80	49.32	32.83	20	43
30						100	125	132.07	100	60.82	41.04	25	50	
SMA5-25	m5	BK	25	50	100	125	132.07	100	60.82	41.04	25	50		
30				125	150	158.07	125	71.82	47.04	30	60			
SMA1-30	1	m1	30	BK	12	24	30	31.41	28	17.71	13.71	10	16	
SMA1.5-30					m1.5	15	36	45	47.12	43	28.24	21.56	16	25
SMA2-30 SMB2-30		m2		20		45	60	62.83	50	29.42	21.41	12.5	25	
15				60	75	78.54	62	36.28	26.27	17	32			
SMA2.5-30 SMB2.5-30		m2.5		BK	25	60	75	78.54	62	36.28	26.27	17	32	
20					75	90	94.24	75	45.47	32.12	20	40		
SMA3-30 SMB3-30		m3		BK	30	32	70	90	94.24	75	45.47	32.12	20	40
25						90	120	125.66	95	54.52	37.83	25	50	
SMA4-30 SMB4-30		m4		BK	30	40	100	120	125.66	95	54.52	37.83	25	50
30						120	150	157.07	120	68.56	48.54	35	62	
SMA5-30	m5	BK	30	55	130	150	157.07	120	68.56	48.54	35	62		
40				150	200	207.07	150	88.56	64.54	45	72			

[Caution on Product Characteristics] ① The dimensions of the keyway marked with \* (depth) are made to old JIS Standards.  
The dimensions of the keyway marked with \*\* are different from the JIS Standards for the bore.

Face width	Holding surface dia.	Keyway	Socket head screw	Allowable torque (N·m)		Allowable torque (kgf·m)		Backlash (mm)	Weight (kg)	Catalog Number
				Bending strength	Surface durability	Bending strength	Surface durability			
J	K	Width × Depth	Size	L						
5	9.86 10	—	M4	4	0.90	0.37	0.091	0.038	0.016 0.014	SMA1-20 SMB1-20
8	15.37	—	M4 M5	6.5	3.13	1.31	0.32	0.13	0.069 0.06	SMA1.5-20 SMB1.5-20
10	21.72	5 × 2.3 5 × 2.3	M5	7	7.17	3.05	0.73	0.31	0.14 0.13	SMA2-20 SMB2-20
12	28.06	5 × 2.3** 6 × 2.8	M6	9.5	13.7	5.90	1.39	0.60	0.27 0.26	SMA2.5-20 SMB2.5-20
15	31.57	7 × 3* 7 × 3* 6 × 2.8	M6 M8 M6	11.5	24.2	10.5	2.47	1.08	0.47 0.44 0.49	SMA3-20 SMB3-20 SMC3-20
20	43.43	7 × 3* 10 × 3.3 8 × 3.3	M8	13.5	57.3	25.4	5.85	2.59	1.00 0.96 1.07	SMA4-20 SMB4-20 SMC4-20
26	54.46	10 × 3.3** 8 × 3.3 10 × 3.3	M8	15	114	51.3	11.7	5.23	1.80 2.04 1.93	SMA5-20 SMB5-20 SMC5-20
6	15.03	—	M4	4	1.48	0.71	0.15	0.072	0.03~0.13	SMA1-25
9	19.54	4 × 1.8	M5	5.75	4.98	2.44	0.51	0.25	0.10	SMA1.5-25
12	26.06	6 × 2.8 5 × 2.3	M6 M5	5	11.8	5.90	1.20	0.60	0.19 0.20	SMA2-25 SMB2-25
15	34.57	5 × 2.3** 6 × 2.8	M6	6	23.1	11.7	2.35	1.19	0.39 0.40	SMA2.5-25 SMB2.5-25
20	37.43	7 × 3* 8 × 3.3	M8	7.5	42.3	21.6	4.31	2.20	0.63 0.69	SMA3-25 SMB3-25
25	55.29	10 × 3.3 8 × 3.3	M8	10	96.8	50.2	9.87	5.12	1.59 1.68	SMA4-25 SMB4-25
30	65.15	12 × 3.3**	M8	12.5	185	96.8	18.8	9.87	2.86	SMA5-25
6	19.03	4 × 1.8	M5	5	2.00	1.11	0.20	0.11	0.03~0.13	SMA1-30
10	25.71	5 × 2.3	M5	8	7.22	4.08	0.74	0.42	0.19	SMA1.5-30
12	36.06	6 × 2.8 5 × 2.3	M6 M5	6.25	16.0	9.20	1.63	0.94	0.32 0.35	SMA2-30 SMB2-30
15	47.57	8 × 3.3 6 × 2.8	M8 M6	8.5	31.2	18.2	3.19	1.86	0.68 0.73	SMA2.5-30 SMB2.5-30
20	53.43	10 × 3.3 8 × 3.3	M8	10	57.8	34.0	5.89	3.46	1.15 1.25	SMA3-30 SMB3-30
25	79.29	12 × 3.3 8 × 3.3	M8	12.5	131	78.3	13.4	7.99	2.81 3.03	SMA4-30 SMB4-30
30	99.15	16 × 4.3	M10	17.5	250	150	25.5	15.3	5.56	SMA5-30



Specifications	
Precision grade	JIS B 1704: 1978 grade 4
Gear teeth	Gleason
Pressure angle	20°
Material	SCM415
Heat treatment	Carburized **
Tooth hardness	55 to 60HRC
Surface treatment	Black oxide coating

\* The precision grade of J Series products is equivalent to the value shown in the table.  
\*\* In the illustration, the area surrounded with --- line is masked during the carburization process (max. HRC40 or so) and can be modified.

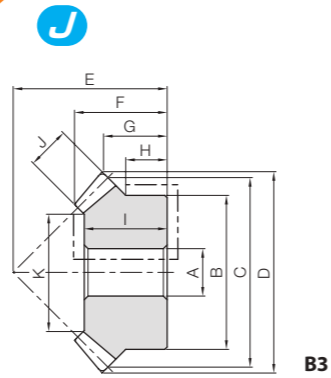

B3

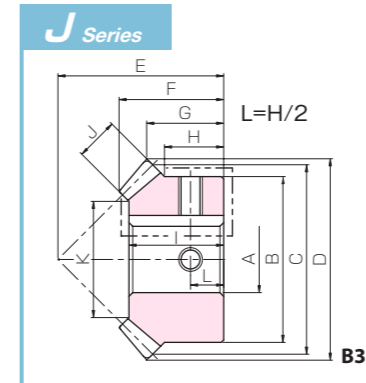

B3K



To order J Series products, please specify: **Catalog No. + J + BORE.**

Catalog Number	Gear Ratio	No. of teeth	Shape	Bore		Pitch dia.	Outside dia.	Mounting distance	Total length	Crown to back	Hub width	Hole length	Face width	Holding surface dia.	Allowable torque (N·m)		Allowable torque (kgf·m)		Backlash (mm)	Weight (kg)
				A <sub>H7</sub>	B										Bending strength	Surface durability	Bending strength	Surface durability		
MM2-20	1	20	B3	12	34	40	42.83	35	22.24	16.41	12	20	9	24.54	15.1	9.74	1.54	0.99	0.06~0.16	0.13
MM2.5-20				15	42	50	53.54	45	28.89	21.77	16	26	11	30.89	29.0	19.0	2.96	1.94	0.07~0.17	0.27
MM3-20				16	52	60	64.24	50	31.19	22.12	16	27	14	34.4	52.0	34.5	5.30	3.52	0.08~0.18	0.43
MM4-20				20	65	80	85.66	65	39.49	27.83	17.5	35	18	49.09	121	81.2	12.3	8.28	0.12~0.27	0.93
MM5-20				25	80	100	107.07	90	60.38	43.54	30	54	26	54.46	256	175	26.1	17.8	0.14~0.34	2.15
MM2-25	1	25	B3	12	45	50	52.83	40	24.33	16.41	12.5	21	12	28.06	26.4	20.1	2.70	2.05	0.06~0.16	0.25
MM2.5-25				16	55	62.5	66.03	50	30.41	20.52	15	27	15	36.57	51.6	39.7	5.27	4.05	0.07~0.17	0.47
MM3-25				20	65	75	79.24	60	37.81	24.62	17.5	33	20	39.43	94.7	73.5	9.66	7.49	0.08~0.18	0.81
MM4-25				25	85	100	105.66	80	49.32	32.83	22.5	44	25	57.29	217	171	22.1	17.4	0.12~0.27	1.89
MM5-25				28	100	125	132.07	100	60.82	41.04	25	50	30	65.15	413	329	42.1	33.6	0.14~0.34	3.41
MM2-30	1	30	B3	12	45	60	62.83	50	29.43	21.41	12.5	25	12	36.06	35.7	31.1	3.64	3.17	0.06~0.16	0.37
MM2.5-30				16	60	75	78.54	62	36.28	26.27	17	32	15	47.57	69.7	61.5	7.11	6.27	0.07~0.17	0.76
MM3-30				20	70	90	94.24	75	45.47	32.12	20	40	20	53.43	129	115	13.2	11.7	0.08~0.18	1.32
MM4-30				28	100	120	125.66	95	54.52	37.83	25	50	25	79.29	293	266	29.9	27.1	0.12~0.27	3.09
MM5-30				28	130	150	157.07	120	68.56	48.54	35	62	30	99.15	558	513	56.9	52.3	0.14~0.34	6.47

Bore H7	* The product shapes of J Series items are identified by background color.																																											
	12	14	15	16	17	18	19	20	22	25	28	30	32	35	40	45	50	55	60	65	70	75	80	85																				
Keyway J <sub>S9</sub>																																												
Screw size	4x1.8				5x2.3				6x2.8				8x3.3				10x3.3				12x3.3				14x3.8				16x4.3				18x4.4				20x4.9				22x5.4			
Catalog Number	M4				M5				M6				M8				M10				M12				M16																			
MM2-20 J BORE																																												
MM2.5-20 J BORE																																												
MM3-20 J BORE																																												
MM4-20 J BORE																																												
MM5-20 J BORE																																												
MM2-25 J BORE																																												
MM2.5-25 J BORE																																												
MM3-25 J BORE																																												
MM4-25 J BORE																																												
MM5-25 J BORE																																												
MM2-30 J BORE																																												
MM2.5-30 J BORE																																												
MM3-30 J BORE																																												
MM4-30 J BORE																																												
MM5-30 J BORE																																												

[Caution on J series] ① Cancellation is not possible for made-to-order products. See page 42 for lead times and allowable order quantities. See page 44 for other precautions.

LM Module 0.8~1.5  
Sintered Metal Miter Gears

Sintered Metal Miter Gears



Specifications	
Precision grade	JIS B 1704: 1978 grade 5
Gear teeth	Gleason
Pressure angle	20°
Material	SMF5040
Heat treatment	—
Tooth hardness	(70 to 95HRB)

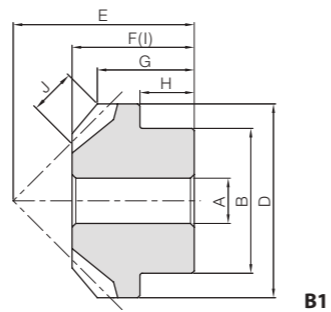

B1

Catalog Number	Gear Ratio	Module	No. of teeth	Shape	Bore		Pitch dia.	Outside dia.	Mounting distance	Total length	Crown to back	Hub width
					A <sub>H8</sub>	B						
LM0.8-20	1	m0.8	20	B1	4	12	16	17.13	16	11	8.57	5.5
LM1-20		m1			5	16	20	21.41	20	13.5	10.71	6
LM1.25-20		m1.25			6	22	25	26.77	23	15	11.38	6
LM1.5-20		m1.5			6	26	30	32.12	30	21	16.06	9

[Caution on Product Characteristics] ① Steam treatment (where the surface is rusted using steam) is provided.  
② The product is not impregnated with lubricating oil.

Hole length	Face width	Holding surface dia.	Allowable torque (N·m)		Allowable torque (kgf·m)		Backlash (mm)	Weight (g)	Catalog Number
			Bending strength	Surface durability	Bending strength	Surface durability			
11	4.24	—	0.22	0.027	0.022	0.0027	0~0.16	9.67	LM0.8-20
13.5	4.95		0.41	0.050	0.042	0.0051	0~0.18	20.7	LM1-20
15	6.36		0.81	0.099	0.083	0.010	0~0.20	38.8	LM1.25-20
21	8.48		1.48	0.19	0.15	0.019	0~0.22	78.6	LM1.5-20





Shaft angle 45°

Specifications	
Precision grade	JIS B 1704: 1978 grade 3
Gear teeth	Gleason
Pressure angle	20°
Material	S45C
Heat treatment	—
Tooth hardness	(less than 194HB)
Surface treatment	Black oxide coating

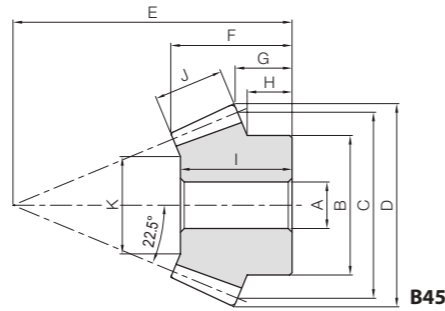

B45

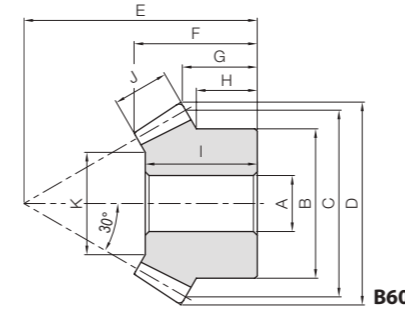

B60

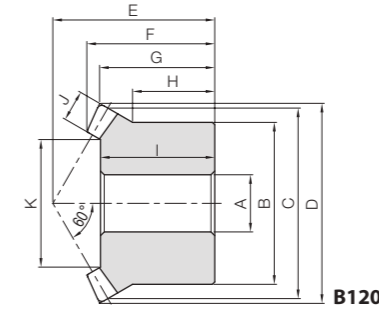

B120

**H** To order Hardened Plus, please specify **Catalog No. + H**. Example: **SAM1.5-20045H**

Catalog Number	Gear Ratio	Module	No. of teeth	Shaft angle	Shape	Bore		Hub dia.	Pitch dia.	Outside dia.	Mounting distance	Total length	Hub width	Hole length					
						A <sub>H7</sub>	B												
<b>SAM1.5-20045</b>	1	<b>m1.5</b>	20	45°	B45	8	25	30	32.77	45	19.33	7.75	18						
<b>SAM2-20045</b>		<b>m2</b>				10	30							40	43.69	60	26.08	9.65	24
<b>SAM2.5-20045</b>		<b>m2.5</b>				12	40							50	54.62	75	31.92	12.58	30
<b>SAM3-20045</b>		<b>m3</b>				14	50							60	65.54	90	38.66	15.51	36
<b>SAM1.5-20060</b>	1	<b>m1.5</b>	20	60°	B60	8	25	30	32.59	40	22.3	12.58	21						
<b>SAM2-20060</b>		<b>m2</b>				12	32							40	43.46	50	26.39	13.05	24
<b>SAM2.5-20060</b>		<b>m2.5</b>				14	40							50	54.33	60	30.49	13.82	28
<b>SAM3-20060</b>		<b>m3</b>				16	50							60	65.19	70	34.59	15.16	32
<b>SAM1.5-20120</b>	1	<b>m1.5</b>	20	120°	B120	8	26	30	31.5	26	20.69	13.88	18						
<b>SAM2-20120</b>		<b>m2</b>				12	34							40	42	34	26.86	17.26	24
<b>SAM2.5-20120</b>		<b>m2.5</b>				14	42							50	52.5	42	33.22	20.64	29
<b>SAM3-20120</b>		<b>m3</b>				16	50							60	63	50	39.39	24.02	35

(Caution on Product Characteristics) ① The shaft angle is where the same products are set together. The shaft angle cannot be changed by using it with a different product.

(Caution on Secondary Operations) ① See Page 22 for more details on Hardened Plus (H Series and HJ Series).

Face width	Holding surface dia.	Allowable torque						Backlash (mm)	Weight (kg)	Catalog Number
		Bending strength		Surface durability		Surface durability <b>H</b>				
J	K	N·m	kgf·m	N·m	kgf·m	N·m	kgf·m			
11	17	4.30	0.44	0.38	0.039	1.60	0.16	0.05~0.15	0.067	<b>SAM1.5-20045</b>
15	20.92	10.3	1.05	0.95	0.097	3.92	0.40	0.06~0.16	0.15	<b>SAM2-20045</b>
18	30.07	19.6	2.00	1.85	0.19	7.54	0.77	0.07~0.17	0.31	<b>SAM2.5-20045</b>
22	34	34.4	3.51	3.30	0.34	13.3	1.36	0.08~0.18	0.55	<b>SAM3-20045</b>
9	18.18	3.54	0.36	0.32	0.033	1.35	0.14	0.05~0.15	0.077	<b>SAM1.5-20060</b>
12	21.93	8.39	0.86	0.78	0.080	3.25	0.33	0.06~0.16	0.15	<b>SAM2-20060</b>
15	29.15	16.4	1.67	1.56	0.16	6.43	0.66	0.07~0.17	0.27	<b>SAM2.5-20060</b>
18	36.36	28.3	2.89	2.74	0.28	11.2	1.14	0.08~0.18	0.47	<b>SAM3-20060</b>
5	19.22	2.43	0.25	0.29	0.030	1.28	0.13	0.05~0.15	0.073	<b>SAM1.5-20120</b>
6.5	26.78	5.66	0.58	0.70	0.072	3.02	0.31	0.06~0.16	0.16	<b>SAM2-20120</b>
8.5	32.03	11.4	1.16	1.45	0.15	6.14	0.63	0.07~0.17	0.31	<b>SAM2.5-20120</b>
10	39.59	19.4	1.98	2.53	0.26	10.6	1.08	0.08~0.18	0.53	<b>SAM3-20120</b>

Product Precautions → Page 310

Precautions for Standard Machined Products → Pages 42~44



Shaft angle 60°



Shaft angle 120°

### Angular Miter Gear Box Example



### Angular miter

The axis angle of a normal miter is set to 90°, but the angle is set arbitrarily for the angular miter. The SAM Angular Miters are products with standardized axial angles of 45°, 60° and 120°. Be sure to pair products with the same model number. Custom items of other shaft angles are available, but may not be manufacturable due to the capabilities of the machine.

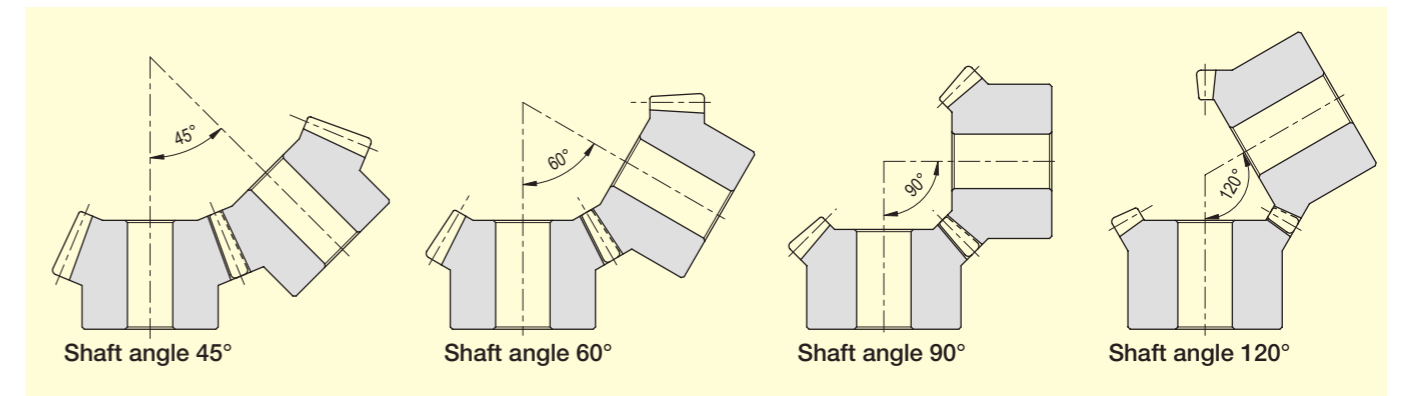



## Stainless Steel Miter Gears



Specifications	
Precision grade	JIS B 1704: 1978 grade 3
Gear teeth	Gleason
Pressure angle	20°
Material	SUS303
Heat treatment	—
Tooth hardness	(less than 187HB)

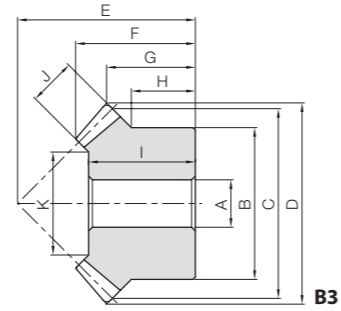

Catalog Number	Gear Ratio	Module	No. of teeth	Shape	Bore	Hub dia.	Pitch dia.	Outside dia.	Mounting distance	Total length	Crown to back	Hub width
					A <sub>H7</sub>	B	C	D	E	F	G	H
SUM1-20	1	m1	20	B3	6	16	20	21.41	20	13.95	10.71	8
SUM1.5-20		8			26	30	32.12	30	21.24	16.06	13	
SUM2-20		12			34	40	42.83	37	24.89	18.41	14	
SUM2.5-20		14			42	50	53.54	48	32.54	24.77	19	
SUM3-20		16			50	60	64.24	58	39.84	30.12	23	
SUM4-20	20	64	80	85.65	75	50.78	37.83	27				
SUM1-25	1	m1	25	B3	6	20	25	26.41	23	15.16	11.21	8
SUM1.5-25		10			30	37.5	39.62	34	22.25	16.31	11.5	
SUM2-25		12			45	50	52.83	40	24.33	16.41	12.5	
SUM2.5-25		16			55	62.5	66.04	50	30.41	20.52	15	
SUM3-25		20			65	75	79.24	60	37.81	24.62	17.5	
SUM4-25	28	80	100	105.66	80	49.32	32.83	20				
SUM2-30	1	m2	30	B3	12	45	60	62.83	50	29.43	21.41	12.5
SUM2.5-30		16			60	75	78.54	62	36.28	26.27	17	
SUM3-30		20			70	90	94.24	75	45.47	32.12	20	

Hole length	Face width	Holding surface dia.	Allowable torque (N·m)		Allowable torque (kgf·m)		Backlash (mm)	Weight (kg)	Catalog Number
			Bending strength	Surface durability	Bending strength	Surface durability			
I	J	K							
12	5	9.86	0.49	0.060	0.050	0.0061	0.03~0.13	0.019	SUM1-20
19	8	15.37	1.72	0.22	0.18	0.022	0.05~0.15	0.075	SUM1.5-20
22	10	21.72	3.94	0.51	0.40	0.052	0.06~0.16	0.15	SUM2-20
29	12	28.06	7.52	1.00	0.77	0.10	0.07~0.17	0.30	SUM2.5-20
35	15	31.57	13.3	1.80	1.36	0.18	0.08~0.18	0.53	SUM3-20
45	20	43.43	31.5	4.39	3.22	0.45	0.12~0.27	1.17	SUM4-20
14	6	15.03	0.81	0.12	0.083	0.012	0.03~0.13	0.035	SUM1-25
19	9	19.54	2.74	0.41	0.28	0.042	0.05~0.15	0.11	SUM1.5-25
20	12	26.06	6.50	1.00	0.66	0.10	0.06~0.16	0.25	SUM2-25
26	15	34.57	12.7	2.00	1.29	0.20	0.07~0.17	0.47	SUM2.5-25
32	20	37.43	23.3	3.73	2.37	0.38	0.08~0.18	0.81	SUM3-25
43	25	55.29	53.2	8.79	5.43	0.90	0.12~0.27	1.75	SUM4-25
25	12	36.06	8.77	1.55	0.89	0.16	0.06~0.16	0.37	SUM2-30
32	15	47.57	17.1	3.10	1.75	0.32	0.07~0.17	0.77	SUM2.5-30
40	20	53.43	31.7	5.86	3.23	0.60	0.08~0.18	1.34	SUM3-30



## Finished Bore Stainless Steel Miter Gears



Specifications	
Precision grade	JIS B 1704: 1978 grade 3
Gear teeth	Gleason
Pressure angle	20°
Material	SUS303
Heat treatment	—
Tooth hardness	(less than 187HB)

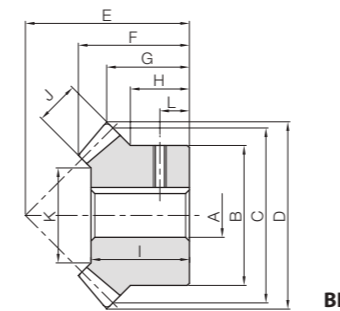
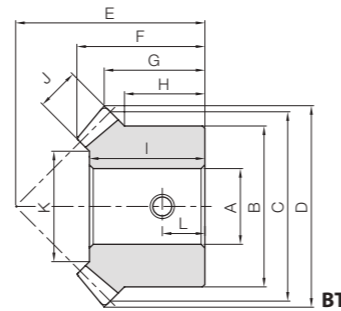

Catalog Number	Gear Ratio	Module	No. of teeth	Shape	Bore	Hub dia.	Pitch dia.	Outside dia.	Mounting distance	Total length	Crown to back	Hub width	Hole length
					A <sub>H7</sub>	B	C	D	E	F	G	H	I
SUMA1-20	1	m1	20	BT	6	16	20	21.41	20	13.95	10.71	8	12
SUMA1.5-20		BT		8	26	30	32.12	30	21.24	16.06	13	19	
SUMA2-20		BK		12	34	40	42.83	37	24.89	18.41	14	22	
SUMA2.5-20		BK		14	42	50	53.54	48	32.54	24.77	19	29	
SUMA3-20		BK		16	50	60	64.24	58	39.84	30.12	23	35	
SUMA4-20	BK	20	64	80	85.65	75	50.78	37.83	27	45			
SUMA1-25	1	m1	25	BT	6	20	25	26.41	23	15.16	11.21	8	14
SUMA1.5-25		BT		10	30	37.5	39.62	34	22.25	16.31	11.5	19	
SUMA2-25		BK		12	45	50	52.83	40	24.33	16.41	12.5	20	
SUMA2.5-25		BK		16	55	62.5	66.04	50	30.41	20.52	15	26	
SUMA3-25		BK		20	65	75	79.24	60	37.81	24.62	17.5	32	
SUMA4-25	BK	30	80	100	105.66	80	49.32	32.83	20	43			

Face width	Holding surface dia.	Keyway	Socket head screw	Allowable torque (N·m)		Allowable torque (kgf·m)		Backlash (mm)	Weight (kg)	Catalog Number
				Bending strength	Surface durability	Bending strength	Surface durability			
J	K	Width × Depth	Size	L						
5	9.86	—	M4	4	0.49	0.060	0.050	0.0061	0.03~0.13	0.018
8	15.37	—	M4	6.5	1.72	0.22	0.18	0.022	0.05~0.15	0.074
10	21.72	4 x 1.8	M4	7	3.94	0.51	0.40	0.052	0.06~0.16	0.15
12	28.06	5 x 2.3	M5	9.5	7.52	1.00	0.77	0.10	0.07~0.17	0.30
15	31.57	5 x 2.3	M5	11.5	13.3	1.80	1.36	0.18	0.08~0.18	0.53
20	43.43	6 x 2.8	M5	13.5	31.5	4.39	3.22	0.45	0.12~0.27	1.16
6	15.03	—	M4	4	0.81	0.12	0.083	0.012	0.03~0.13	0.034
9	19.54	—	M4	6	2.74	0.41	0.28	0.042	0.05~0.15	0.11
12	26.06	4 x 1.8	M4	6.5	6.50	1.00	0.66	0.10	0.06~0.16	0.25
15	34.57	5 x 2.3	M5	7.5	12.7	2.00	1.29	0.20	0.07~0.17	0.47
20	37.43	6 x 2.8	M5	9	23.3	3.73	2.37	0.38	0.08~0.18	0.81
25	55.29	8 x 3.3	M6	10	53.2	8.79	5.43	0.90	0.12~0.27	1.70



Specifications	
Precision grade	JIS B 1704: 1978 grade 4*
Gear teeth	Gleason
Pressure angle	20°
Material	MC901
Heat treatment	—
Tooth hardness	(115 to 120HRR)

\* The precision grade is equivalent to the value shown in the table.

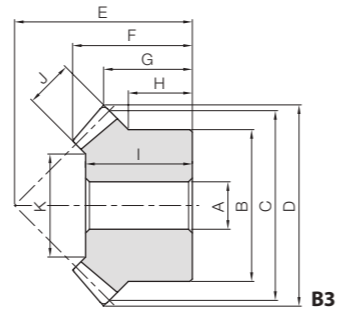

B3

\* In regard to MC Nylon gears, other materials are available for plastic gears, including Ultra High Molecular Weight Polyethylene (U-PE), which has excellent abrasion resistance and resin conforming to the Plastic Implementation Measure (PIM). A single piece order is acceptable and will be produced as a custom-made gear. Please see Page 26 for more details on quotations and orders.

Catalog Number	Gear Ratio	Module	No. of teeth	Shape	Bore	Hub dia.	Pitch dia.	Outside dia.	Mounting distance	Total length	Crown to back	Hub width
					A <sub>H8</sub>	B	C	D	E	F	G	H
PM1-20	1	m1	20	B3	6	16	20	21.41	20	13.95	10.71	8
PM1.25-20		m1.25			8	22	25	26.77	23	15.27	11.38	9
PM1.5-20		m1.5			8	26	30	32.12	30	21.24	16.06	13
PM2-20		m2			10	34	40	42.83	37	24.89	18.41	14
PM2.5-20		m2.5			12	42	50	53.54	48	32.54	24.77	19
PM3-20		m3			14	50	60	64.24	58	39.84	30.12	23
PM3.5-20		m3.5			20	60	70	74.95	65	44.13	32.47	25
PM4-20		m4			20	64	80	85.66	75	50.78	37.83	27
PM1-25	1	m1	25	B3	6	20	25	26.41	23	15.16	11.21	8
PM1.5-25		m1.5			8	30	37.5	39.62	34	22.25	16.31	11.5
PM2-25		m2			10	40	50	52.83	40	24.33	16.41	10
PM2.5-25		m2.5			14	50	62.5	66.04	50	30.41	20.52	12.5
PM3-25		m3			15	60	75	79.24	60	37.81	24.62	15

[Caution on Product Characteristics] ① To reduce heat generation, it is recommended to mate plastic gears with steel gears.

Hole length	Face width	Holding surface dia.	Allowable torque (N·m)		Allowable torque (kgf·m)		Backlash (mm)	Weight (g)	Catalog Number
			Bending strength	Surface durability	Bending strength	Surface durability			
12	5	9.86	0.22	—	0.022	—	0~0.23	2.77	PM1-20
13	6	13.03	0.42	—	0.043	—	0~0.24	5.31	PM1.25-20
19	8	15.37	0.76	—	0.077	—	0~0.25	11.0	PM1.5-20
22	10	21.72	1.74	—	0.18	—	0~0.26	22.5	PM2-20
29	12	28.06	3.34	—	0.34	—	0~0.27	45.9	PM2.5-20
35	15	31.57	5.89	—	0.60	—	0~0.28	79.8	PM3-20
40	18	39.09	9.47	—	0.97	—	0~0.30	121	PM3.5-20
45	20	43.43	14.0	—	1.42	—	0~0.32	170	PM4-20
14	6	15.03	0.36	—	0.036	—	0~0.23	5.13	PM1-25
19	9	19.54	1.20	—	0.12	—	0~0.25	17.0	PM1.5-25
20	12	26.06	2.84	—	0.29	—	0~0.26	32.7	PM2-25
26	15	34.57	5.55	—	0.57	—	0~0.27	63.9	PM2.5-25
32	20	37.43	10.0	—	1.02	—	0~0.28	115	PM3-25



Specifications	
Precision grade	JIS B 1704: 1978 grade 6*
Gear teeth	Gleason
Pressure angle	20°
Material	Duracon (R) (M90-44) **
Heat treatment	—
Tooth hardness	(110 to 120HRR)

\* The precision grade is equivalent to the value shown in the table.

\*\* "Duracon (R)" is a registered trademark of Polyplastics Co., Ltd. in Japan as well as other countries.

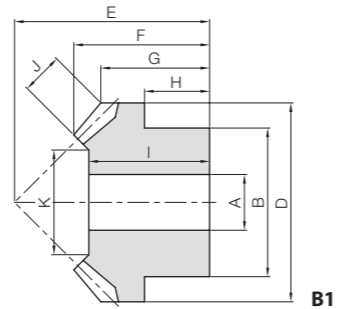

B1



When using the injection molded bevel gear as an idler gear and a shaft diameter smaller than the inside diameter of the molded gear, please press fit one of the standard bushings. For details on bushings, please see Page 338.

■ Dimensional tolerance of molded item (unit: mm)

Dimensional classification	Grade	Rough grade
	3 or less	±0.20
4 to 6	±0.25	±0.30
7 to 10	±0.30	±0.35
11 to 18	±0.35	±0.40
19 to 30	±0.40	±0.50
Over 30	±0.50	±0.50

Catalog Number	Gear Ratio	Module	No. of teeth	Shape	Bore	Hub dia.	Pitch dia.	Outside dia.	Mounting distance	Total length	Crown to back
					A	B	D	E	F	G	
DM0.5-20	1	m0.5	20	B1	3	8	10	10.71	11	7.97	6.35
DM0.8-20		m0.8			5	12	16	17.13	16	10.83	8.56
DM1-20		m1			6	16	20	21.41	21	14.62	11.71
DM1.5-20		m1.5			8	20	30	32.12	30	20.59	16.06

[Caution on Product Characteristics] ① The bore tolerance is -0.05 to -0.30, but it may be slightly higher at the center of the hole.

② For the dimensional accuracy of each part, see the dimensional tolerance of molded items in the table at right.

[Caution on Secondary Operations] ① As it is a molded item, bubbles may form inside the material. Avoid performing secondary operations.

Hub width	Hole length	Face width	Holding surface dia.	Allowable torque (N·m)		Backlash (mm)	Weight (g)	Catalog Number
				Bending strength	Bending strength			
4	7	2.5	4.93	0.082	0.0083	0~0.30	0.57	DM0.5-20
5	10	3.5	10.1	0.31	0.032	0~0.48	1.93	DM0.8-20
7	13	4.5	11.27	0.54	0.055	0~0.60	4.28	DM1-20
10	19	7	18.2	0.96	0.098	0~0.60	11.8	DM1.5-20



# BB Sintered Metal Bushings



When using the injection molded bevel gear as an idler gear and a shaft diameter smaller than the inside diameter of the molded gear, please press fit one of the following standard bushings.

Catalog Number	Inner dia.	Outside dia.	Length	Gear example
	$d \begin{smallmatrix} +0.02 \\ 0 \end{smallmatrix}$	$D \begin{smallmatrix} +0.02 \\ -0.01 \end{smallmatrix}$	$L \begin{smallmatrix} 0 \\ -0.3 \end{smallmatrix}$	
<b>BB30507</b>	3	5	7	DM0.8
<b>BB30608</b>	3	6	8	DM1
<b>BB40609</b>	4	6	9	DM1
<b>BB50814</b>	5	8	14	DM1.5

Material: Oil-free copper alloy

## Sintered Metal Bushings

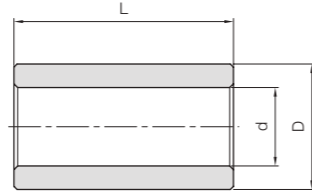

T8



# Bevel Gears

MHP High-Ratio Hypoid Gears	MBSG Ground Spiral Bevel Gears	SBSG Ground Spiral Bevel Gears	MBSA/MBSB Finished Bore Spiral Bevel Gears	SBS Spiral Bevel Gears	SB-H Hardened Bevel Gears	SB Bevel Gears	SBY-H Hardened Bevel Gears
Gear Ratio 15-60	Gear Ratio 2	Gear Ratio 1.5-3	Gear Ratio 1.5-3	Gear Ratio 1.5-4	Gear Ratio 1.5-4 <b>NEW</b>	Gear Ratio 1.5-4	Gear Ratio 2-4 <b>NEW</b>
Material: SCM415	Material: SCM415	Material: S45C	Material: SCM415	Material: S45C	Material: S45C	Material: S45C	Material: S45C
m1, 1.5 Page 346	m2-4 Page 350	m2-4 Page 352	m2-6 Page 354	m1-5 Page 358	m1-6 Page 362	m1-6 Page 362	m5-8 Page 362
SBY Bevel Gears	SB-H Hardened Steel Bevel Gears & Pinion Shafts	SB Steel Bevel Gears & Pinion Shafts	SUB Stainless Steel Bevel Gears	PB Plastic Bevel Gears	DB Injection Molded Bevel Gears	BB Sintered Metal Bushings	Nissei KSP Ground Spiral Bevel Gears
Gear Ratio 2-4	Gear Ratio 5 <b>NEW</b>	Gear Ratio 5	Gear Ratio 1.5-3	Gear Ratio 1.5-3	Gear Ratio 2		Gear Ratio 1-2
Material: S45C	Material: S45C	Material: S45C	Material: SUS303	Material: MC901	Material: Duracon (R) (M90-44)	Material: Oil-free copper alloy	Material: SCM415
m5-8 Page 362	m1.5-3 Page 366	m1.5-3 Page 366	m1.5-3 Page 368	m1-2 Page 370	m0.5-1 Page 372	φ 5-6 Page 372	m1.5-6 Page 374

## Catalog Number of KHK Stock Gears

The Catalog Number for KHK stock gears is based on the simple formula listed below. Please order KHK gears by specifying the Catalog Numbers.

(Example) Bevel Gears

**MBSG 2-40 20 R**



Spur Gears  
Helical Gears  
Internal Gears  
Racks  
CP Racks & Pinions  
Miter Gears  
Bevel Gears  
Screw Gears  
Worm Gears  
Gearboxes  
Other Products

Spur Gears  
Helical Gears  
Internal Gears  
Racks  
CP Racks & Pinions  
Miter Gears  
Bevel Gears  
Screw Gears  
Worm Gears  
Gearboxes  
Other Products