

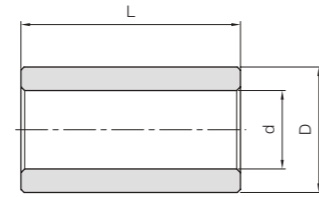

# BB Sintered Metal Bushings



When using the injection molded bevel gear as an idler gear and a shaft diameter smaller than the inside diameter of the molded gear, please press fit one of the following standard bushings.



T8



Catalog Number	Inner dia.	Outside dia.	Length	Gear example
	$d \begin{smallmatrix} +0.02 \\ 0 \end{smallmatrix}$	$D \begin{smallmatrix} +0.02 \\ -0.01 \end{smallmatrix}$	$L \begin{smallmatrix} 0 \\ -0.3 \end{smallmatrix}$	
<b>BB30507</b>	3	5	7	DM0.8
<b>BB30608</b>	3	6	8	DM1
<b>BB40609</b>	4	6	9	DM1
<b>BB50814</b>	5	8	14	DM1.5

Material: Oil-free copper alloy

## Sintered Metal Bushings



# Bevel Gears

MHP High-Ratio Hypoid Gears	MBSG Ground Spiral Bevel Gears	SBSG Ground Spiral Bevel Gears	MBSA/MBSB Finished Bore Spiral Bevel Gears	SBS Spiral Bevel Gears	SB-H Hardened Bevel Gears	SB Bevel Gears	SBY-H Hardened Bevel Gears
Gear Ratio 15~60	Gear Ratio 2	Gear Ratio 1.5~3	Gear Ratio 1.5~3	Gear Ratio 1.5~4	Gear Ratio 1.5~4 <b>NEW</b>	Gear Ratio 1.5~4	Gear Ratio 2~4 <b>NEW</b>
Material: SCM415 m1, 1.5 Page 346	Material: SCM415 m2~4 Page 350	Material: S45C m2~4 Page 352	Material: SCM415 m2~6 Page 354	Material: S45C m1~5 Page 358	Material: S45C m1~6 Page 362	Material: S45C m1~6 Page 362	Material: S45C m5~8 Page 362
SBY Bevel Gears	SB-H Hardened Steel Bevel Gears & Pinion Shafts	SB Steel Bevel Gears & Pinion Shafts	SUB Stainless Steel Bevel Gears	PB Plastic Bevel Gears	DB Injection Molded Bevel Gears	BB Sintered Metal Bushings	Nissei KSP Ground Spiral Bevel Gears
Gear Ratio 2~4	Gear Ratio 5 <b>NEW</b>	Gear Ratio 5	Gear Ratio 1.5~3	Gear Ratio 1.5~3	Gear Ratio 2		Gear Ratio 1~2
Material: S45C m5~8 Page 362	Material: S45C m1.5~3 Page 366	Material: S45C m1.5~3 Page 366	Material: SUS303 m1.5~3 Page 368	Material: MC901 m1~2 Page 370	Material: Duracon (R) (M90-44) m0.5~1 Page 372	Material: Oil-free copper alloy φ 5~6 Page 372	Material: SCM415 m1.5~6 Page 374

## Catalog Number of KHK Stock Gears

The Catalog Number for KHK stock gears is based on the simple formula listed below. Please order KHK gears by specifying the Catalog Numbers.

(Example) Bevel Gears

### MBSG 2-40 20 R



Spur Gears  
Helical Gears  
Internal Gears  
Racks  
CP Racks & Pinions  
Miter Gears  
Bevel Gears  
Screw Gears  
Worm Gears  
Gearboxes  
Other Products

Spur Gears  
Helical Gears  
Internal Gears  
Racks  
CP Racks & Pinions  
Miter Gears  
Bevel Gears  
Screw Gears  
Worm Gears  
Gearboxes  
Other Products

Features



KHK stock bevel gears are available in two types, spiral bevel gears and straight bevel gears, in gear ratios of 1.5 through 5, and are offered in a large variety of modules, numbers of teeth, materials and styles. The following table lists the main features for easy selection.

Type	Catalog Number	Module	Gear Ratio	Material	Heat Treatment	Tooth Surface Finish	Precision JIS B 1704: 1978	Secondary Operations	Features
Hypoid Gear	MHP	1, 1.5	15~60	SCM415	Carburized Note 1	Cut	3	△	Hypoid gears that have been tempered and hardened that are capable of rapid deceleration.
Spiral Bevel Gears	MBSG	2~4	2	SCM415	Carburized Note 1	Ground	1	△	Gears that have been hardened and ground that has excellent accuracy, strength and abrasion resistance. Secondary operations are possible except for the teeth.
	SBSG	2~4	1.5~3	S45C	Gear teeth induction hardened	Ground	2	△	Gears that has been hardened and ground with a good balance of accuracy, wear resistance and cost. Secondary operations are possible except for the teeth.
	KSP	1.5~6	1~2	SCM415	Carburized Note 1	Ground	0	△	Gears that have been hardened and ground that has grade-0 accuracy, strength, abrasion resistance and quietness. Secondary operations can be given except for the teeth.
	MBSA/MBSB	2~6	1.5~3	SCM415	Carburized Note 1	Cut	4	×	Gears that have been fully hardened that have excellent strength and wear resistance. Can be used in the finished shape.
	SBS	1~5	1.5~4	S45C	Gear teeth induction hardened	Cut	4	△	Gears that have been hardened with excellent wear resistance. Secondary operations are possible except for the teeth.
Straight Bevel Gears	SB/SBY	1~8	1.5~5	S45C	—	Cut	3	○	Many lineups are available at a low price. The teeth can be additionally hardened.
	SUB	1.5~3	1.5~3	SUS303	—	Cut	3	○	Stainless steel gears with rust resistance.
	PB	1~2	1.5~3	MC901	—	Cut	4	○	Nylon gears can be used with no lubrication.
	DB	0.5~1	2	Duracon (R) (M90-44) NOTE 2	—	Injection Molded	6	△	Low-priced gears made through injection molding. Suitable for light loads.

[NOTE 1] Although these are carburized products, secondary operations can be performed on the areas that are masked during the carburization. However, note that high hardness (HRC40 at maximum) occurs in some cases.  
 [NOTE 2] "Duracon (R)" is a registered trademark of Polyplastics Co., Ltd. in Japan as well as other countries.

Application Examples



Bevel gears are used as power transmission components of intersecting axes.

Differential Gear Mechanism Example



Image provided by: PK Design

SHESCO 2WD Bike



SB Bevel Gears are used in the driving components in both the front and rear wheels

Selection Hints



Please select the most suitable products by carefully considering the characteristics of items and contents of the product tables. It is also important to read all applicable "CAUTION" notes shown below before the final selection.

1. Caution in Selecting the Mating Gears

Basically, KHK stock bevel gears should be selected as shown in the catalog in pairs (e.g. MBSG2-4020R should mate with MBSG2-2040L). But, for straight tooth bevel gears, there is some interchangeability with different series. For plastic bevel gears, we recommend metal mating gears for good heat conductivity.

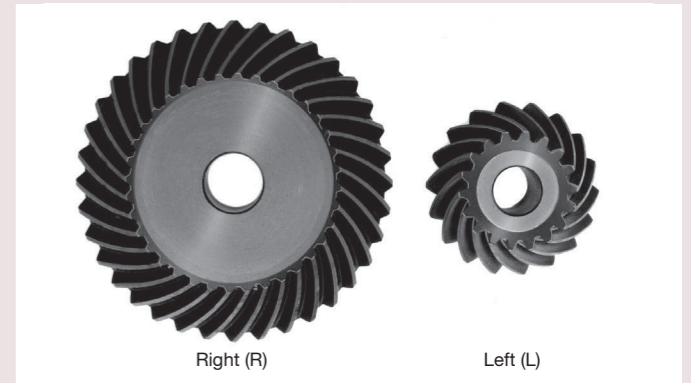

Selection Chart for Straight Bevel Gears (○ Allowable × Not allowable)

Pinion \ Gears	SB SBY	SUB	PB	DB
SB-SBY	○	○	○	×
SUB	○	○	○	×
PB	○	○	○	×
DB	×	×	×	○

Selection Chart for Spiral Bevel Gears (○ Allowable × Not allowable)

Pinion \ Gears	MBSG	SBSG	MBSA MBSB	SBS
MBSG	○	×	×	×
SBSG	×	○	×	×
MBSA/MBSB	×	×	○	×
SBS	×	×	×	○

2. Caution in Selecting Gears Based on Gear Strength

The gear strength values shown in the product pages were computed by assuming the application environment in the table below. Therefore, they should be used as reference only. We recommend that each user computes their own values by applying the actual usage conditions.

Calculation of Bending Strength of Gears

Item	Catalog Number	MBSG MBSA MBSB	SBSG/SBS	SB NOTE 2 SBY	SB-H SBY-H	SUB	PB	DB
Formula NOTE 1	Formula of bevel gears on bending strength (JGMA403-01)						The Lewis formula	
No. of teeth of mating gears	No. of teeth of the mating gear of the set						—	
Rotational Speed of Pinion	100rpm (600rpm for MBSG and SBSG)						100rpm	
Design Life (Durability)	Over 10 <sup>7</sup> cycles						—	
Impact from motor	Uniform load						Allowable bending stress (kgf/mm <sup>2</sup> )	
Impact from load	Uniform load						1.15 (40°C with No Lubrication)	m 0.5 4.0 m 0.8 4.0 m 1.0 3.5 (40°C with Grease Lubrication)
Direction of load	Bidirectional load (calculated with allowable bending stress of 2/3)							
Allowable bending stress at root $\sigma_{Hlim}$ (kgf/mm <sup>2</sup> )	47	21	19 (24.5)	19	10.5			
Safety factor $K_R$	1.2							

Calculation of Surface Durability (Except where it is common with bending strength)

Item	Catalog Number	MBSG MBSA MBSB	SBSG/SBS	SB NOTE 2 SBY	SB-H SBY-H	SUB	PB	DB
Formula NOTE 1	Formula of bevel gears on surface durability (JGMA404-01)							
Kinematic viscosity of lubricant	100cSt (50°C)							
Gear support	Shafts & gear box have normal stiffness, and gears are supported on one end							
Allowable Hertz stress $\sigma_{Hlim}$ (kgf/mm <sup>2</sup> )	166	90	49 (62.5)	90	41.3			
Safety factor $C_R$	1.15							

[NOTE 1] The gear strength formula is based on JGMA (Japanese Gear Manufacturers Association) specifications, "MC Nylon Technical Data" by Mitsubishi Chemical Advanced Materials and "Duracon (R) Gear" by Polyplastics Co. The units for the rotational speed (rpm) and the stress (kgf/mm<sup>2</sup>) are adjusted to the units needed in the formula.

[NOTE 2] Since SB Bevel Pinion Shafts are thermally refined, the allowable tooth-root bending stress and allowable hertz stress are the value shown in parentheses.

**Product Precautions**

**Common Notes**
**[Caution on Product Characteristics]**

- (1) The allowable torque shown in the table are calculated values according to the assumed usage conditions. Please see Page 341 for more details.
- (2) Dimensions of the outside diameter, the total length and crown to back length are all theoretical values, and some differences will occur due to the corner chamfering of the gear tips.
- (3) These bevel gears produce axial thrust forces. Please see Page 344 for more details.
- (4) Variations in temperature or humidity can cause dimensional changes in plastic gears, including tooth diameter, bore, and backlash. The accuracy and tolerances shown in the catalog are values obtained when machining is performed.
- (5) Keyways are made according to JIS B1301 standards, Js9 tolerance. Also note that keyway tooth position alignment is not performed.
- (6) For products having a tapped hole, a set screw is included. (excludes B7)
- (7) See Page 22 for more details on Hardened Plus (H Series and HJ Series).
  - KHK's Specifications for Heat Treatment
    - Hardened location: Tooth surface, or Tooth surface and Tooth root
    - Hardness: 50 to 60 HRC
  - \* Hardness and Depth of Gear-teeth Induction Hardening
    - The hardening method and the state of the hardened teeth area vary depending on the size of gears.
    - Since different hardening treatment is applied in accordance with the module and number of teeth, the hardness level is referred to as the hardness of the reference diameter.
    - For some of our products, the hardness at tooth tip / root may not be equal to the hardness you designated.
    - As to the effective case depth, it is specified by JIS, as "The distance from the surface of the case to the area with hardness HV450." The case depth differs from area to area of a tooth, so the depth cannot be specified.
    - Due to the gear teeth being induction hardened, no secondary operations can be performed on tooth areas including the bottom land (approx. 2 to 3 mm).

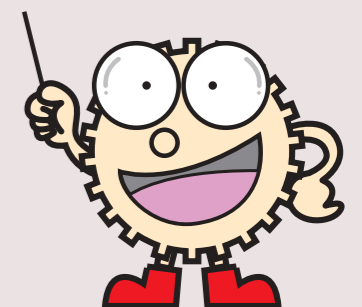
**MEMO**

## Application Hints



In order to use KHK stock bevel gears safely, carefully read the Application Hints before proceeding. If there are questions or you require clarifications, please contact our technical department or your nearest distributor.  
E-mail: info@khkgears.net

Please read "Cautions on Performing Secondary Operations" below when performing modifications and/or secondary operations for safety concerns.

### 1. Cautions on Handling

- ① KHK products are packaged one by one to prevent scratches and dents, but if you find issues such as rust, scratches, or dents when the product is removed from the box after purchase, please contact the supplier.
- ② Depending on the handling method, the product may become deformed or damaged. Plastic gears and ring gears deform particularly easily, so please handle with care.

### 2. Caution on Performing Secondary Operations

- ① If re boring, it is important to pay special attention to locating the center in order to avoid runout.
- ② The reference datum for gear machining is the bore. Therefore, use the bore for locating the center. If it is too difficult to do for small bores, the alternative is to use one spot on the bore and the runout of the side surface.
- ③ If reworking using scroll chucks, we recommend the use of new or rebored jaws for improved precision. Please exercise caution not to crush the teeth.

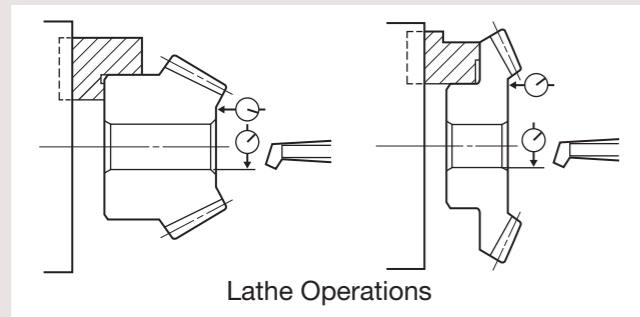

- ④ For items with induction hardened teeth, the hardness is high near the tooth root. When machining the front face, the machined area should be 4 to 6mm smaller than the holding surface diameter dimensions.

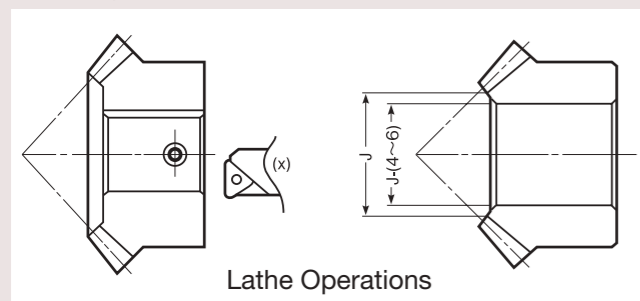

- ⑤ For tapping and keyway operations, see the examples given in "Caution on Performing Secondary Operations" in KHK Stock Spur Gear section. When cutting keyways, to avoid stress concentration, always round the corners.
- ⑥ PB plastic bevel gears are susceptible to changes due to temperature and humidity. Dimensions may change between, during, and after re-machining operations.

- ⑦ When induction-hardening S45C products, thermal stress cracks may appear. Also, note that the precision grade of the product declines by 1 or 2 grades, as deformation on material may occur. If you require tolerance for bore or other parts, machining is necessary after heat treatment.
- ⑧ For the handling conveniences, the SB and SBY series listed below have the tapped holes (180° apart, 2 places) on the holding surface. We appreciate your understanding. Please pay attention to the machining position.

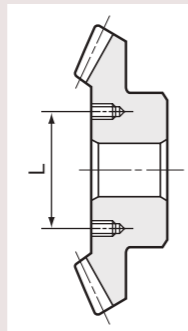

Catalog Number	L(mm)	Tap Size
SB6-4515	130	M10 deep 20
SBY8-4020	160	M10 deep 20
SBY8-4515	210	M10 deep 20
SBY5-6015	160	M10 deep 20
SBY6-6015	220	M10 deep 20

### 3. Points of Caution during Assembly

- ① Since bevel gears are cone shaped, they produce axial thrust forces. Especially for spiral bevel gears, the directions of thrust change with the hand of helix and the direction of rotation. This is illustrated below. The bearings must be selected properly to be able to handle these thrust forces. For details, use gear calculation software GCSW.

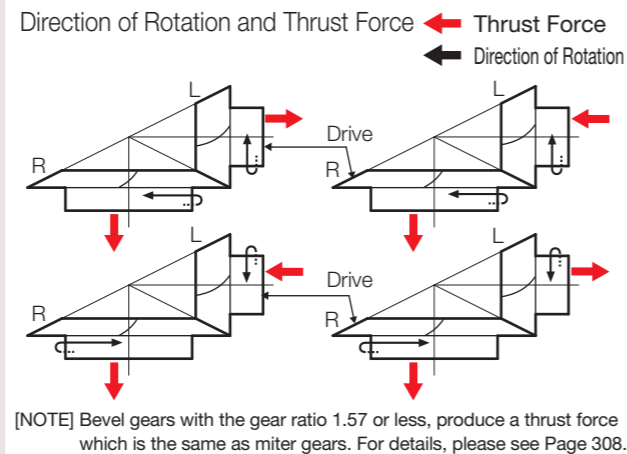

- ② If a gear is mounted on a shaft far from the bearings, the shaft may bend. We recommend designing bevel gears to be as close to the bearings as possible. Design the gear box, shaft and bearing with high rigidity.
- ③ Be sure to fasten the bevel gear to prevent the gears from moving, as thrust acts on it while rotating.

- ④ When installing MBSA or MBSB spiral bevel gears produced in B7 style (ring gear), always secure the gears onto the mounting base with taper pins to absorb the rotational loads. It is dangerous to secure with bolts only.

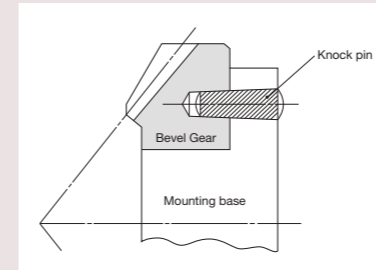

- ⑤ The recommended assemble distance tolerance of KHK stock bevel gears is H7 for ground gears and H8 for cut gears. Mounting distance error, offset error and shaft angle error must be minimized to avoid excessive noise and wear. Inaccurate assembly will lead to irregular noises and uneven wear. Various conditions of tooth contact are shown below. Also, when changing the normal direction backlash, adjust the mounting distance according to the amount of axial movement shown in the table below so as not to change the tooth contact.

Gear Ratio (Reduction Ratio)	Normal direction backlash	Travel in axial direction	
		Pinion	Gears
1.5	$J_n$	$0.81 \times J_n$	$1.22 \times J_n$
2		$0.65 \times J_n$	$1.31 \times J_n$
2.5		$0.54 \times J_n$	$1.36 \times J_n$
3		$0.46 \times J_n$	$1.39 \times J_n$
4		$0.35 \times J_n$	$1.42 \times J_n$
5		$0.29 \times J_n$	$1.43 \times J_n$
15 or more		$1.4 \times J_n \div \text{Gear Ratio}$	$1.4 \times J_n$

### Correct Tooth Contact

- When assembled correctly, the contact will occur on both gears in the middle of the flank and center of face width but somewhat closer to the toe.

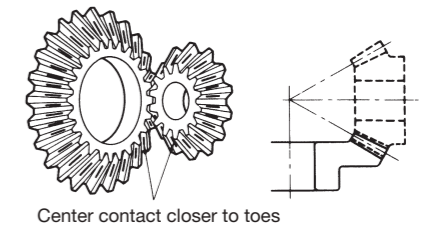

### Incorrect Tooth Contact

#### Mounting Distance Error

- When the mounting distance of the pinion is incorrect, the contact will occur too high on the flank on one gear and too low on the other.

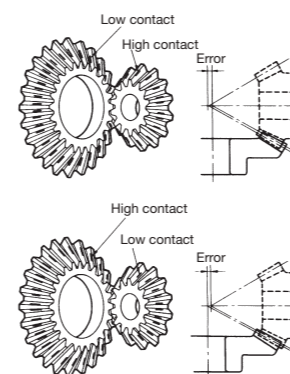

#### Offset Error

- When the pinion shaft is offset, the contact surface is near the toe of one gear and near the heel of the other.

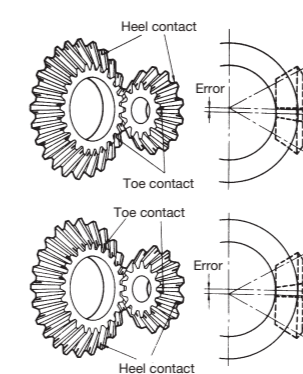

#### Shaft Angle Error

- When there is an angular error of shafts, the gears will contact at the toes or heels depending on whether the angle is greater or less than 90°.

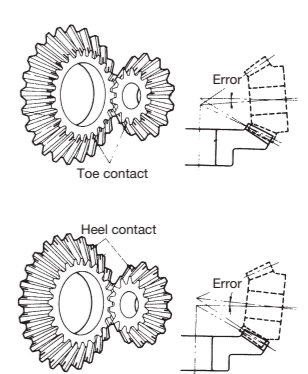

Features of MHP High Ratio Hypoid Gears

A pair of MHP high-ratio hypoid gears are able to produce an amazing reduction of speed of 60:1 in one stage.

- Total-cost reduction**  
The MHP provides a compact gearing body replacing several stages of reduction gears. This reduces the cost sharply.
- High efficiency**  
Compared to worm gear drives, the MHP has less sliding contact. The resulting higher efficiency allows the use of smaller motors. (See graph on the right)
- High rigidity**  
The carburized hypoid gears lead to smaller size than comparable worms gears.
- Compact gear assembly**  
The size of the gear housing is nearly the same as outer diameter of the large gear. (See the diagrams below)

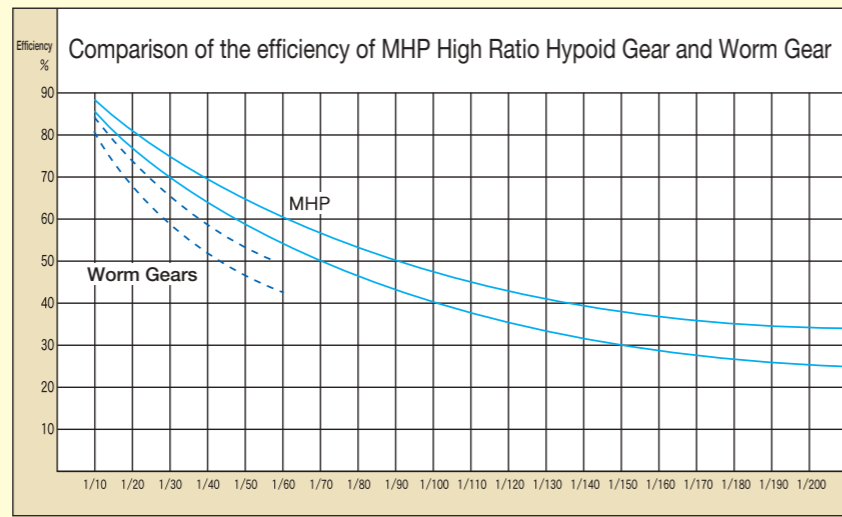

How to determine the radial and thrust loads

Before using the MHP high-ratio hypoid gears, be sure to confirm the direction of radial and thrust loads. Following equations are used to compute these loads. The radial and thrust load coefficients are given on the product pages.

Comparison of MHP and Worm Gear

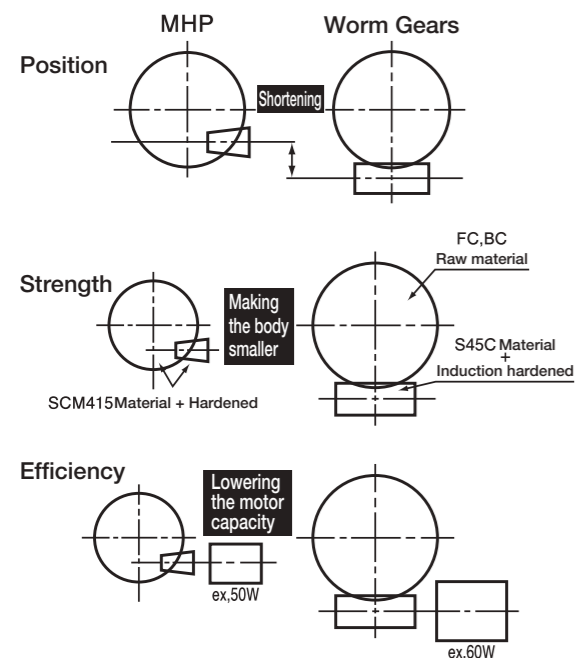

Radial load calculation

$W_{RP}$  : Radial load on the pinion or L(N)

$$W_{RP} = W_{KP} \times T_G \times \frac{n}{z}$$

$W_{KP}$  : Radial load coefficient of pinion or L (given on the product pages)

$T_G$  : Torque of gear or R(N-m)

$n$  : Number of teeth of pinion or L

$z$  : Number of teeth of gear or R

$W_{RG}$  : Radial load on the gear or R(N)

$$W_{RG} = W_{KG} \times T_G$$

$W_{KG}$  : Radial load coefficient of gear or R (given on the product pages)

$T_G$  : Torque of gear or R(N-m)

Thrust load

$W_{XP}$  : Thrust load on the pinion or L(N)

$$W_{XP} = W_{NP} \times T_G \times \frac{n}{z}$$

$W_{NP}$  : Thrust load coefficient of pinion or L (given on the product page)

$T_G$  : Torque of gear or R(N-m)

$n$  : Number of teeth of pinion or L

$z$  : Number of teeth of gear or R

$W_{XG}$  : Thrust load of gear or R(N)

$$W_{XG} = W_{NG} \times T_G$$

$W_{NG}$  : Thrust load coefficient of gear or R (given on the product pages)

$T_G$  : Torque of gear or R(N-m)

Variations in tooth contact due to poor alignment of gears

If the gear engagement position is out of the normal position, variations in tooth contact, as illustrated below, may appear.

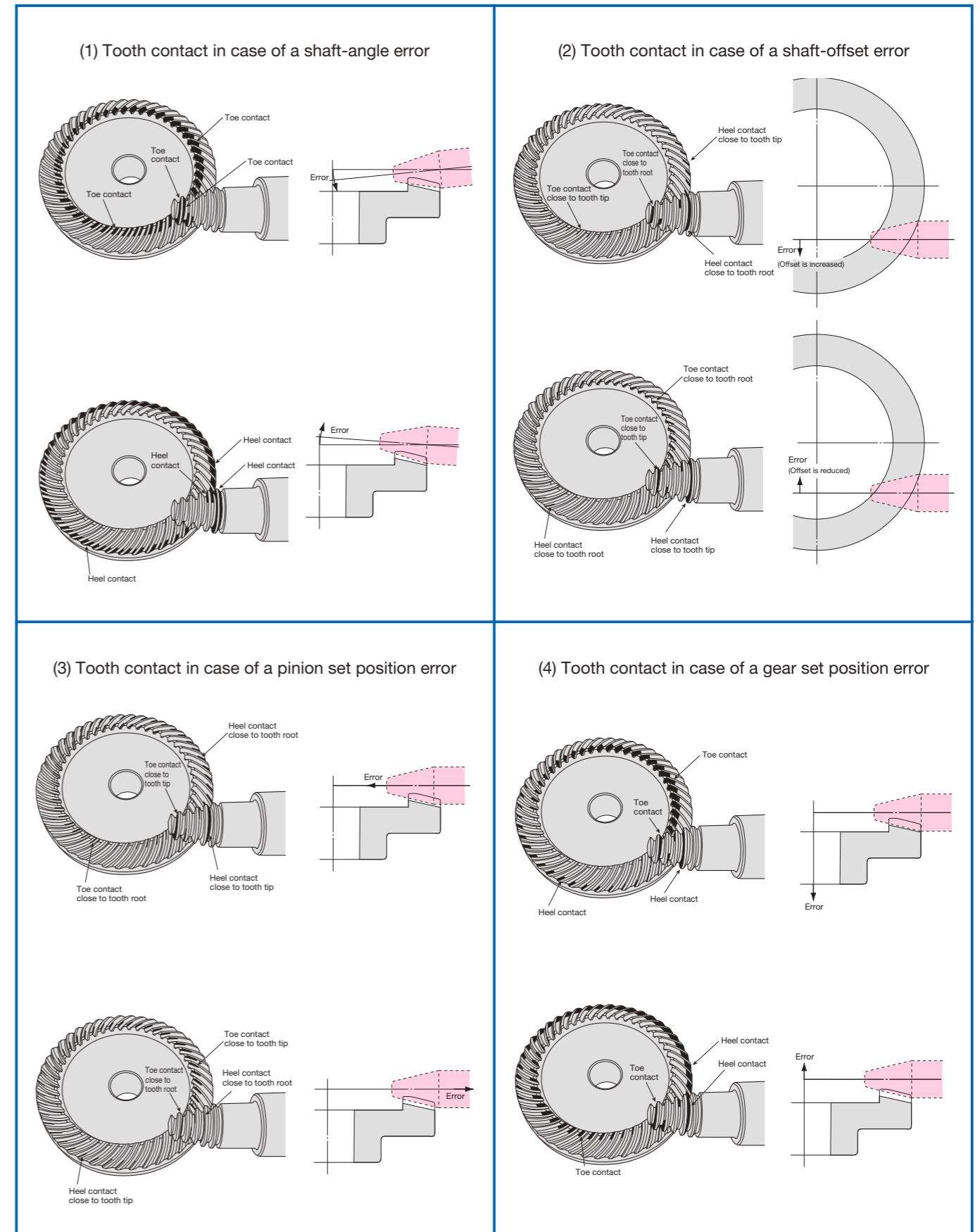





Specifications	
Precision grade	JIS B 1704: 1978 grade 1
Gear teeth	Gleason
Pressure angle	20°
Helix angle	35°
Material	SCM415
Heat treatment	Carburized *
Tooth hardness	55 to 60HRC

\* In the illustration, the area surrounded with ---- line is masked during the carburization process (max. HRC40 or so) and can be modified.

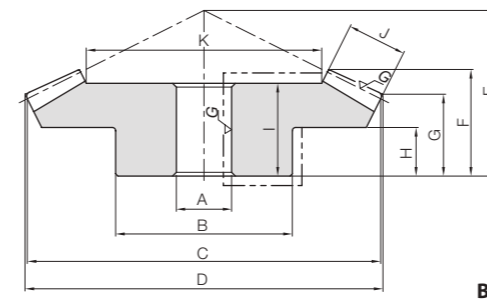
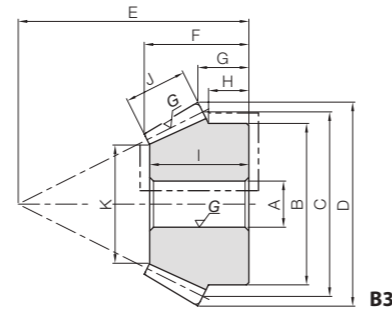

Catalog Number	Gear Ratio	Module	No. of teeth	Direction of spiral	Shape	Bore		Hub dia.	Pitch dia.	Outside dia.	Mounting distance		Total length	Crown to back											
						A <sub>H7</sub>	B				C	D		E	F	G									
MBSG2-4020R MBSG2-2040L	2	m2	40	R	B4	15	45	80	81.1	45	31.78	26.1	13.75	27	14	52.7 25.39	56.5 28.2	94.2 47.1	5.76 2.88	9.61 4.80	0.04~0.10	0.57 0.18	MBSG2-4020R MBSG2-2040L		
			20	L	B3	12	35	40	44.1	55	28.16	16.02													
MBSG2.5-4020R MBSG2.5-2040L	2	m2.5	40	R	B4	16	55	100	101.29	50	33.35	26.29	16	13.25	30	29	17	66.99 29.97	108 54.1	184 91.8	11.0 5.52	18.7 9.37	0.05~0.11	1.01 0.31	MBSG2.5-4020R MBSG2.5-2040L
			20	L	B3	12	43	50	55.12	65	31.01	16.28													
MBSG3-4020R MBSG3-2040L	2	m3	40	R	B4	20	65	120	121.57	60	39.81	31.57	20	18	35	36.5	20	80.28 36.56	185 92.4	318 159	18.8 9.42	32.4 16.2	0.06~0.12	1.64 0.56	MBSG3-4020R MBSG3-2040L
			20	L	B3	16	52	60	66.03	80	38.9	21.51													
MBSG4-4020R MBSG4-2040L	2	m4	40	R	B4	25	80	160	162.06	75	48.27	37.06	22	17.5	42	43	27	106.63 51.25	441 221	778 389	45.0 22.5	79.3 39.7	0.09~0.15	3.55 1.20	MBSG4-4020R MBSG4-2040L
			20	L	B3	20	70	80	88.46	100	45.38	22.12													

Hub width	Hole length	Face width	Holding surface dia.	Allowable torque (N·m)		Allowable torque (kgf·m)		Backlash (mm)	Weight (kg)	Catalog Number
				Bending strength	Surface durability	Bending strength	Surface durability			
18	29	14	52.7	56.5	94.2	5.76	9.61	0.04~0.10	0.57	MBSG2-4020R MBSG2-2040L
13.75	27	14	25.39	28.2	47.1	2.88	4.80			
16	30	17	66.99	108	184	11.0	18.7	0.05~0.11	1.01	MBSG2.5-4020R MBSG2.5-2040L
13.25	29	17	29.97	54.1	91.8	5.52	9.37			
20	35	20	80.28	185	318	18.8	32.4	0.06~0.12	1.64	MBSG3-4020R MBSG3-2040L
18	36.5	20	36.56	92.4	159	9.42	16.2			
22	42	27	106.63	441	778	45.0	79.3	0.09~0.15	3.55	MBSG4-4020R MBSG4-2040L
17.5	43	27	51.25	221	389	22.5	39.7			

Product Precautions → Page 342

### Mating surface of spiral bevel gears

Spiral bevel gears have convex and concave tooth surfaces. If the direction of rotation of the drive gear differs, the meshing tooth surface will also change. The table on the right shows how to view the convex and concave tooth surfaces and the meshing tooth surface with respect to the direction of rotation of the drive gear.

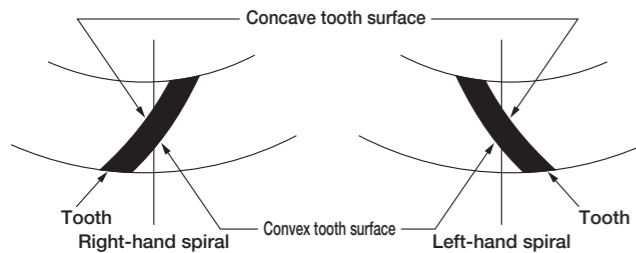

#### For right-hand drive gear

Direction of rotation of drive gear <small>NOTE 1</small>	Meshing tooth surface	
	Right-hand drive gear	Left-hand driven gear
Clockwise	Convex tooth surface	Concave tooth surface
Counterclockwise	Concave tooth surface	Convex tooth surface

#### For left-hand drive gear

Direction of rotation of drive gear <small>NOTE 1</small>	Meshing tooth surface	
	Left-hand drive gear	Right-hand driven gear
Clockwise	Concave tooth surface	Convex tooth surface
Counterclockwise	Convex tooth surface	Concave tooth surface

[NOTE 1] The direction of rotation in the table is as seen from the hub of the gear.

### The force applied to the teeth of the spiral bevel gear

The table below shows, for spiral bevel gears with an axis angle of  $\Sigma = 90^\circ$ , pressure angle of  $\alpha_n = 20^\circ$  and spiral angle of  $\beta_m = 35^\circ$ , the magnitudes of the axial force  $F_x$  and radial force  $F_r$  where the tangential force  $F_t$  at the center of the tooth width is 100.

Thrust force  $F_x$   
Radial force  $F_r$  value

#### (1) Force applied to pinion

Meshing tooth surface	Gear Ratio $z_2/z_1$						
	1.0	1.5	2.0	2.5	3.0	4.0	5.0
Concave tooth surface	80.9	82.9	82.5	81.5	80.5	78.7	77.4
Convex tooth surface	-18.1	-1.9	8.4	15.2	20.0	26.1	29.8
Concave tooth surface	80.9	82.9	82.5	81.5	80.5	78.7	77.4
Convex tooth surface	-18.1	-33.6	-42.8	-48.5	-52.4	-57.2	-59.9
Convex tooth surface	80.9	75.8	71.1	67.3	64.3	60.1	57.3

#### (2) Force applied to gear

Meshing tooth surface	Gear Ratio $z_2/z_1$						
	1.0	1.5	2.0	2.5	3.0	4.0	5.0
Concave tooth surface	80.9	75.8	71.1	67.3	64.3	60.1	57.3
Convex tooth surface	-18.1	-33.6	-42.8	-48.5	-52.4	-57.2	-59.9
Concave tooth surface	80.9	82.9	82.5	81.5	80.5	78.7	77.4
Convex tooth surface	-18.1	-1.9	8.4	15.2	20.0	26.1	29.8
Convex tooth surface	80.9	75.8	71.1	67.3	64.3	60.1	57.3



Specifications	
Precision grade	JIS B 1704: 1978 grade 2
Gear teeth	Gleason
Pressure angle	20°
Helix angle	35°
Material	S45C
Heat treatment	Gear teeth induction hardened *
Tooth hardness	50 to 60HRC
Surface treatment	Black oxide coated except for ground part

\* Due to the gear teeth being induction hardened, no secondary operations can be performed on tooth areas including the bottom land (approx. 2 to 3 mm).

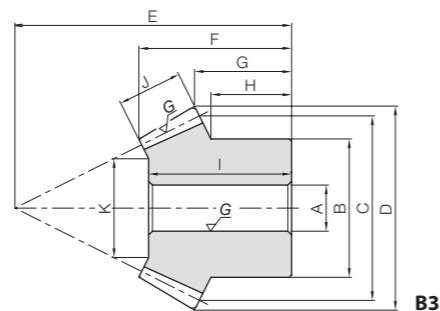

B3

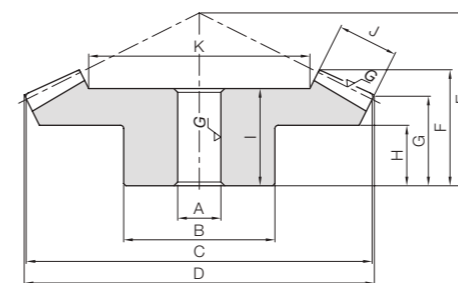

B4

Catalog Number	Gear Ratio	Module	No. of teeth	Direction of spiral	Shape	Bore		Hub dia.		Pitch dia.		Outside dia.		Mounting distance		Total length		Crown to back		
						A <sub>H7</sub>	B	C	D	E	F	G	H	I	J	K	L	M	N	O
SBSG2-3020R SBSG2-2030L	1.5	m2	30	R	B4	12	35	60	61.6	40	26.6	21.2								
			20	L	B3	10	30	40	43.55	45	24.91	16.18								
SBSG2.5-3020R SBSG2.5-2030L	1.5	m2.5	30	R	B4	15	45	75	77.09	50	33.86	26.56								
			20	L	B3	12	40	50	54.43	55	30.88	18.98								
SBSG3-3020R SBSG3-2030L	1.5	m3	30	R	B4	16	50	90	92.21	55	35.34	26.66								
			20	L	B3	16	45	60	65.58	70	40.17	26.86								
SBSG4-3020R SBSG4-2030L	1.5	m4	30	R	B4	20	70	120	122.85	75	47.49	37.14								
			20	L	B3	20	60	80	87.34	90	48.17	32.45								
SBSG2-4020R SBSG2-2040L	2	m2	40	R	B4	12	40	80	80.99	45	32.26	25.99								
			20	L	B3	12	32	40	44.1	60	34.04	21.02								
SBSG2.5-4020R SBSG2.5-2040L	2	m2.5	40	R	B4	15	50	100	101.27	55	39.65	31.27								
			20	L	B3	12	40	50	55.21	75	43.61	26.3								
SBSG3-4020R SBSG3-2040L	2	m3	40	R	B4	20	60	120	121.48	65	45.76	36.48								
			20	L	B3	16	50	60	66.06	90	50.63	31.52								
SBSG4-4020R SBSG4-2040L	2	m4	40	R	B4	20	70	160	162.07	80	53.69	42.07								
			20	L	B3	20	60	80	88.5	120	66.24	42.12								
SBSG2-4515R SBSG2-1545L	3	m2	45	R	B4	12	40	90	90.67	40	30.29	26.01								
			15	L	B3	10	24	30	34.78	60	29.66	15.8								
SBSG2.5-4515R SBSG2.5-1545L	3	m2.5	45	R	B4	15	50	112.5	113.32	50	38.25	32.47								
			15	L	B3	12	30	37.5	43.36	75	38.27	19.73								
SBSG3-4515R SBSG3-1545L	3	m3	45	R	B4	20	60	135	135.99	55	40.59	33.98								
			15	L	B3	15	38	45	52.08	90	44.98	23.68								

Hub width	Hole length	Face width	Holding surface dia.	Allowable torque (N·m)		Allowable torque (kgf·m)		Backlash (mm)	Weight (kg)	Catalog Number
				Bending strength	Surface durability	Bending strength	Surface durability			
H	I	J	K							
15	23	11	37.56	14.1	14.2	1.44	1.44	0.05~0.11	0.26	SBSG2-3020R
11.67	22		21.34	9.61	9.44	0.98	0.96		0.13	SBSG2-2030L
18	30	15	45.61	29.0	29.7	2.96	3.03	0.06~0.12	0.55	SBSG2.5-3020R
14.17	28		27.42	19.8	19.8	2.02	2.02		0.28	SBSG2.5-2030L
17	31	17	57.14	48.4	50.4	4.94	5.14	0.07~0.13	0.82	SBSG3-3020R
20	37		34.71	33.1	33.6	3.37	3.42		0.49	SBSG3-2030L
25	40	20	78.59	106	113	10.8	11.5	0.10~0.16	1.90	SBSG4-3020R
23.33	43		46.89	72.2	75.3	7.36	7.68		1.05	SBSG4-2030L
18	27	15	48.46	25.5	26.7	2.60	2.73	0.05~0.11	0.51	SBSG2-4020R
18	32		20.92	12.8	13.4	1.30	1.36		0.19	SBSG2-2040L
20	34	20	59.28	51.7	55.1	5.27	5.62	0.06~0.12	1.06	SBSG2.5-4020R
22.5	40		20.56	25.9	27.6	2.64	2.81		0.42	SBSG2.5-2040L
24	38	22	73.81	84.8	91.9	8.65	9.38	0.07~0.13	1.67	SBSG3-4020R
27.5	47		29.61	42.5	46.0	4.33	4.69		0.69	SBSG3-2040L
28	45	28	102.39	195	217	19.9	22.2	0.10~0.16	3.33	SBSG4-4020R
35	62		42.78	97.9	109	9.98	11.1		1.53	SBSG4-2040L
17	26	15	59.04	34.8	28.1	3.55	2.87	0.05~0.11	0.60	SBSG2-4515R
14	29		19.13	11.2	9.38	1.14	0.96		0.095	SBSG2-1545L
22	35	20	72.84	59.0	48.3	6.01	4.93	0.06~0.12	1.21	SBSG2.5-4515R
17.5	37		20.51	18.9	16.1	1.93	1.64		0.19	SBSG2.5-1545L
20	35	23	88.18	99.3	82.5	10.1	8.41	0.07~0.13	1.99	SBSG3-4515R
21.33	44		28.54	31.8	27.5	3.24	2.80		0.34	SBSG3-1545L

Product Precautions



Page 342

### ■ Mating surface of spiral bevel gears

Spiral bevel gears have convex and concave tooth surfaces. If the direction of rotation of the drive gear differs, the meshing tooth surface will also change. The table on the right shows how to view the convex and concave tooth surfaces and the meshing tooth surface with respect to the direction of rotation of the drive gear.

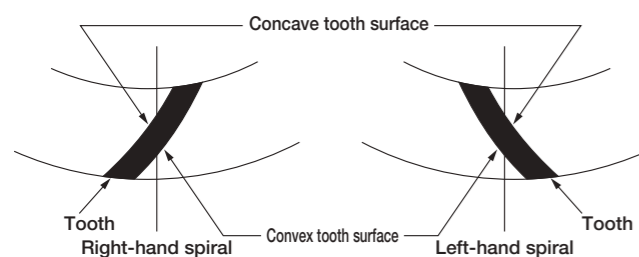

#### For right-hand drive gear

Direction of rotation of drive gear NOTE 1	Meshing tooth surface	
	Right-hand drive gear	Left-hand driven gear
Clockwise	Convex tooth surface	Concave tooth surface
Counterclockwise	Concave tooth surface	Convex tooth surface

#### For left-hand drive gear

Direction of rotation of drive gear NOTE 1	Meshing tooth surface	
	Left-hand drive gear	Right-hand driven gear
Clockwise	Concave tooth surface	Convex tooth surface
Counterclockwise	Convex tooth surface	Concave tooth surface

[NOTE 1] The direction of rotation in the table is as seen from the hub of the gear.

### ■ The force applied to the teeth of the spiral bevel gear

The table below shows, for spiral bevel gears with an axis angle of  $\Sigma = 90^\circ$ , pressure angle of  $\alpha_n = 20^\circ$  and spiral angle of  $\beta_m = 35^\circ$ , the magnitudes of the axial force  $F_x$  and radial force  $F_r$  where the tangential force  $F_t$  at the center of the tooth width is 100.

Thrust force  $F_x$   
Radial force  $F_r$  value

#### (1) Force applied to pinion

Meshing tooth surface	Gear Ratio $z_2/z_1$						
	1.0	1.5	2.0	2.5	3.0	4.0	5.0
Concave tooth surface	80.9	82.9	82.5	81.5	80.5	78.7	77.4
	-18.1	-1.9	8.4	15.2	20.0	26.1	29.8
Convex tooth surface	-18.1	-33.6	-42.8	-48.5	-52.4	-57.2	-59.9
	80.9	75.8	71.1	67.3	64.3	60.1	57.3

#### (2) Force applied to gear

Meshing tooth surface	Gear Ratio $z_2/z_1$						
	1.0	1.5	2.0	2.5	3.0	4.0	5.0
Concave tooth surface	80.9	75.8	71.1	67.3	64.3	60.1	57.3
	-18.1	-33.6	-42.8	-48.5	-52.4	-57.2	-59.9
Convex tooth surface	-18.1	-1.9	8.4	15.2	20.0	26.1	29.8
	80.9	82.9	82.5	81.5	80.5	78.7	77.4



Specifications	
Precision grade	JIS B 1704: 1978 grade 4
Gear teeth	Gleason
Pressure angle	20°
Helix angle	35°
Material	SCM415
Heat treatment	Carburized *
Tooth hardness	55 to 60HRC

\* No secondary operations can be performed on these finished gears due to the applied carburizing process.

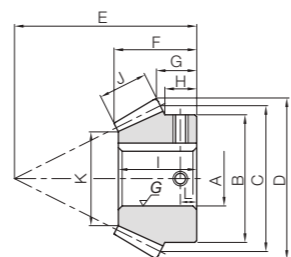

BK

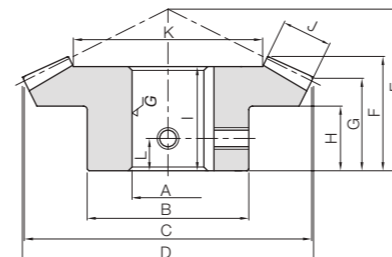

B4

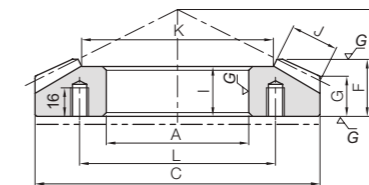

B7

Catalog Number	Gear Ratio	Module	No. of teeth	Direction of spiral	Shape	Bore	Hub dia.	Pitch dia.	Outside dia.	Mounting distance	Total length	Crown to back	Hub width	Hole length	
						A <sub>H7</sub>	B	C	D	E	F	G	H	I	
MBSA2-3020R MBSB2-3020R	1.5	m2	30	R	B4	20	40	60	61.36	40	26.8	21.02	14	23	
22															
MBSA2-2030L MBSB2-2030L		m2	20	L	BK	15	35	40	43.49	45	24.96	16.16	13.33	23	
18															
MBSA2.5-3020R MBSB2.5-3020R		m2.5	30	R	B4	22	48	75	76.74	50	33.6	26.31	18	30	
25															
MBSA2.5-2030L MBSB2.5-2030L		m2.5	20	L	BK	18	43	50	54.43	55	30.08	18.98	15.17	28	
20															
MBSA3-3020R MBSB3-3020R		m3	30	R	B4	25	60	90	92.21	60	40.34	31.66	21	36	
30															
MBSA3-2030L MBSB3-2030L		m3	20	L	BK	22	53	60	65.58	65	35.17	21.86	17.67	32.5	
25															
MBSA4-3020R MBSB4-3020R		m4	30	R	B4	35	75	120	122.91	70	43.99	32.18	21	39	
40															
MBSA4-2030L MBSB4-2030L		m4	20	L	BK	30	70	80	87.34	85	45.53	27.45	21.67	42	
35															
MBSA5-3020R MBSA5-2030L MBSB5-2030L		m5	30	R	B7	80	—	150	—	70	35.53	23.8	—	31	
35						40	87	100	109.2	105	55.05	33.07	25.67	51	
MBSA6-3020R MBSA6-2030L MBSB6-2030L		m6	30	R	B7	90	—	180	—	80	38.86	24.37	—	33	
45						50	105	120	130.48	125	65.57	38.49	30	60	
MBSA2-4020R MBSB2-4020R		2	m2	40	R	B4	20	45	80	81.06	45	31.83	26.06	18	29
22															
MBSA2-2040L MBSB2-2040L			m2	20	L	BK	15	35	40	44.2	55	28.16	16.05	13.75	27
18															
MBSA2.5-4020R MBSB2.5-4020R	m2.5		40	R	B4	25	55	100	101.29	50	33.35	26.29	16	30	
28															
MBSA2.5-2040L MBSB2.5-2040L	m2.5		20	L	BK	20	43	50	55.12	65	31.01	16.28	13.25	29	
22															
MBSA3-4020R MBSB3-4020R	m3		40	R	B4	30	65	120	121.57	60	39.81	31.57	21	35	
35															
MBSA3-2040L MBSB3-2040L	m3		20	L	BK	22	53	60	66.03	80	38.9	21.51	18.25	36.5	
25															
MBSA4-4020R MBSA4-2040L MBSB4-2040L	m4		40	R	B7	80	—	160	—	60	32.08	22.53	—	28	
30						35	70	80	88.46	100	45.38	22.12	17.5	43	
MBSA5-4020R MBSA5-2040L MBSB5-2040L	m5		40	R	B7	90	—	200	—	70	35.2	22.98	—	30	
40						45	87	100	109.91	125	57.11	27.48	21.75	53.5	
MBSA6-4020R MBSA6-2040L MBSB6-2040L	m6		40	R	B7	110	—	240	—	80	37.89	23.62	—	32	
50						55	105	120	132.04	150	67.8	33.01	26.25	64	

[Caution on Product Characteristics] ① The keyway tolerance is the value before hardening.

Face width	Holding surface dia.	Keyway	Socket head screw	Allowable torque (N·m)		Allowable torque (kgf·m)		Backlash (mm)	Weight (kg)	Catalog Number	
				Bending strength	Surface durability	Bending strength	Surface durability				
J	K	Width × Depth	Size	L							
11	37.56	6 x 2.8 6 x 2.8	2-M5 2-M5	7	34.4	38.4	3.51	3.91	0.06~0.16	0.26 0.24	MBSA2-3020R MBSB2-3020R
11	24.34	5 x 2.3 6 x 2.8	2-M4 2-M5	6.5	23.5	25.6	2.39	2.61		0.14 0.13	MBSA2-2030L MBSB2-2030L
14	48.01	6 x 2.8 8 x 3.3	2-M5 2-M6	9	68.0	76.8	6.93	7.84	0.07~0.17	0.52 0.49	MBSA2.5-3020R MBSB2.5-3020R
14	31.02	6 x 2.8 6 x 2.8	2-M5 2-M5	7.5	46.4	51.2	4.73	5.22		0.26 0.25	MBSA2.5-2030L MBSB2.5-2030L
17	57.14	8 x 3.3 8 x 3.3	2-M6 2-M6	11	118	135	12.1	13.8	0.08~0.18	0.96 0.90	MBSA3-3020R MBSB3-3020R
17	36.2	6 x 2.8 8 x 3.3	2-M5 2-M6	9	80.7	90.1	8.23	9.19		0.46 0.43	MBSA3-2030L MBSB3-2030L
23	76.72	10 x 3.3 12 x 3.3	2-M8 2-M8	10	283	328	28.9	33.5	0.12~0.27	1.77 1.68	MBSA4-3020R MBSB4-3020R
23	48.07	8 x 3.3 10 x 3.3	2-M6 2-M8	11	193	219	19.7	22.3		1.03 0.95	MBSA4-2030L MBSB4-2030L
28	97.36	—	6-M10	110	544	637	55.4	64.9	0.14~0.34	2.80	MBSA5-3020R
28	62.04	10 x 3.3 12 x 3.3	2-M8 2-M8	13	371	425	37.8	43.3		2.01 1.89	MBSA5-2030L MBSB5-2030L
34	115.61	—	6-M10	120	927	1120	94.6	114	0.16~0.36	4.55	MBSA6-3020R
34	72.41	14 x 3.8 14 x 3.8	2-M10 2-M10	15	633	745	64.5	76.0		3.56 3.38	MBSA6-2030L MBSB6-2030L
14	52.7	6 x 2.8 6 x 2.8	2-M5 2-M5	9	59.6	69.6	6.08	7.09	0.06~0.16	0.53 0.51	MBSA2-4020R MBSB2-4020R
14	25.39	5 x 2.3 6 x 2.8	2-M4 2-M5	7	29.9	34.8	3.05	3.55		0.16 0.14	MBSA2-2040L MBSB2-2040L
17	66.99	8 x 3.3 8 x 3.3	2-M6 2-M6	8	114	135	11.7	13.8	0.07~0.17	0.93 0.90	MBSA2.5-4020R MBSB2.5-4020R
17	29.97	6 x 2.8 6 x 2.8	2-M5 2-M5	7	57.3	67.6	5.84	6.89		0.26 0.25	MBSA2.5-2040L MBSB2.5-2040L
20	80.28	8 x 3.3 10 x 3.3	2-M6 2-M8	11	195	233	19.9	23.7	0.08~0.18	1.47 1.40	MBSA3-4020R MBSB3-4020R
20	36.56	6 x 2.8 8 x 3.3	2-M5 2-M6	9.5	97.7	116	9.97	11.9		0.51 0.48	MBSA3-2040L MBSB3-2040L
27	107.63	—	6-M10	110	466	564	47.5	57.5	0.12~0.27	3.11	MBSA4-4020R
27	51.25	8 x 3.3 10 x 3.3	2-M6 2-M8	9	234	282	23.8	28.8		1.05 0.96	MBSA4-2040L MBSB4-2040L
34	133.97	—	6-M10	120	915	1120	93.3	114	0.14~0.34	5.59	MBSA5-4020R
34	61.95	12 x 3.3 14 x 3.8	2-M8 2-M10	11	458	559	46.7	57.0		1.96 1.82	MBSA5-2040L MBSB5-2040L
40	162.56	—	6-M10	140	1530	1920	156	196	0.16~0.36	8.48	MBSA6-4020R
40	77.11	14 x 3.8 16 x 4.3	2-M10 2-M10	14	766	961	78.1	97.9		3.33 3.11	MBSA6-2040L MBSB6-2040L

When installing products produced in B7 style (ring type), always secure the gears onto the mounting base with taper pins to absorb the rotational loads. It is dangerous to secure with bolts only.

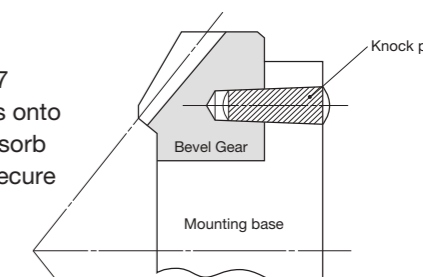



Specifications	
Precision grade	JIS B 1704: 1978 grade 4
Gear teeth	Gleason
Pressure angle	20°
Helix angle	35°
Material	SCM415
Heat treatment	Carburized *
Tooth hardness	55 to 60HRC

\* No secondary operations can be performed on these finished gears due to the applied carburizing process.

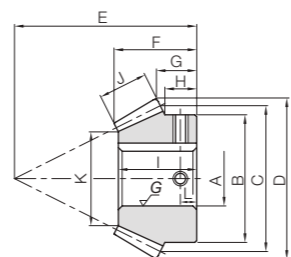

BK

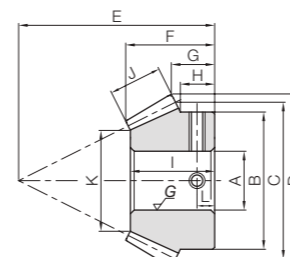

BT

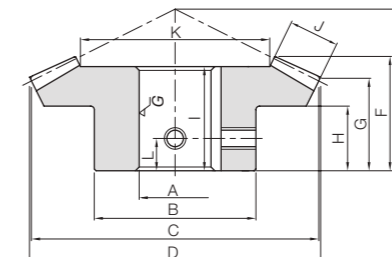

B4

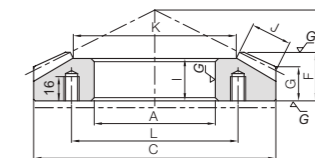

B7

Catalog Number	Gear Ratio	Module	No. of teeth	Direction of spiral	Shape	Bore	Hub dia.	Pitch dia.	Outside dia.	Mounting distance	Total length	Crown to back	Hub width	Hole length
						A <sub>H7</sub>	B	C	D	E	F	G	H	I
MBSA2-4515R MBSB2-4515R	3	m2	45	R	B4	20	48	90	90.66	40	30.01	25.99	18	27
22						48	90	90.66	40	30.01	25.99	18	27	
MBSA2-1545L MBSB2-1545L		m2	15	L	BT	10	26	30	34.59	55	23.78	10.77	9.33	22.5
12						26	30	34.59	55	23.78	10.77	9.33	22.5	
MBSA2.5-4515R MBSB2.5-4515R		m2.5	45	R	B4	22	55	112.5	113.28	45	32.43	27.42	18	28
25						55	112.5	113.28	45	32.43	27.42	18	28	
MBSA2.5-1545L MBSB2.5-1545L		m2.5	15	L	BK	12	32	37.5	43.06	70	30.51	14.68	12.84	29
15						32	37.5	43.06	70	30.51	14.68	12.84	29	
MBSA3-4515R MBSB3-4515R		m3	45	R	B4	30	65	135	136.03	55	39.94	34.05	22	35
32						65	135	136.03	55	39.94	34.05	22	35	
MBSA3-1545L MBSB3-1545L		m3	15	L	BK	18	38	45	52	85	38.12	18.67	16.33	36.5
20						38	45	52	85	38.12	18.67	16.33	36.5	
MBSA4-4515R		m4	45	R	B7	80	—	180	—	50	28.85	22.14	—	25
MBSA4-1545L MBSB4-1545L						m4	15	L	BK	22	52	60	69.24	110
25		52	60	69.24	110					47.51	21.54	18.67	45.5	
MBSA5-4515R		m5	45	R	B7	90	—	225	—	60	33.57	25.16	—	28
MBSA5-1545L MBSB5-1545L						m5	15	L	BK	28	65	75	86.55	135
32		65	75	86.55	135					56.89	24.43	20.83	54	
MBSA6-4515R	m6	45	R	B7	110	—	270	—	70	38.28	28.05	—	32	
MBSA6-1545L MBSB6-1545L					m6	15	L	BK	35	78	90	103.13	160	66.39
40	78	90	103.13	160					66.39	27.19	23	63		

[Caution on Product Characteristics] ① The keyway tolerance is the value before hardening.

Face width	Holding surface dia.	Keyway	Socket head screw	Allowable torque (N·m)		Allowable torque (kgf·m)		Backlash (mm)	Weight (kg)	Catalog Number	
				Bending strength	Surface durability	Bending strength	Surface durability				
J	K	Width × Depth	Size	L							
14	61.82	6 x 2.8 6 x 2.8	2-M5 2-M5	9	67.8	61.3	6.91	6.25	0.06~0.16	0.61 0.60	MBSA2-4515R MBSB2-4515R
14	16.46	— 4 x 1.8	2-M4 2-M4	5	21.7	20.4	2.22	2.08		0.081 0.073	MBSA2-1545L MBSB2-1545L
17	77.83	6 x 2.8 8 x 3.3	2-M5 2-M6	9	130	119	13.3	12.1	0.07~0.17	1.01 0.98	MBSA2.5-4515R MBSB2.5-4515R
17	21.48	4 x 1.8 5 x 2.3	2-M4 2-M4	7	41.6	39.6	4.24	4.04		0.16 0.15	MBSA2.5-1545L MBSB2.5-1545L
21	92.39	8 x 3.3 10 x 3.3	2-M6 2-M8	11	229	211	23.3	21.6	0.08~0.18	1.78 1.75	MBSA3-4515R MBSB3-4515R
21	26.18	6 x 2.8 6 x 2.8	2-M5 2-M5	9	73.3	70.5	7.48	7.18		0.26 0.24	MBSA3-1545L MBSB3-1545L
28	124.3	—	6-M10	110	542	508	55.3	51.8	0.12~0.27	3.93	MBSA4-4515R
28	35.91	6 x 2.8 8 x 3.3	2-M5 2-M6	10	174	169	17.7	17.3		0.63 0.58	MBSA4-1545L MBSB4-1545L
35	154.88	—	6-M10	120	1060	1000	108	102	0.14~0.34	7.38	MBSA5-4515R
35	42.64	8 x 3.3 10 x 3.3	2-M6 2-M8	11	339	334	34.6	34.1		1.16 1.07	MBSA5-1545L MBSB5-1545L
42	186.12	—	6-M10	140	1790	1740	183	178	0.16~0.36	12.0	MBSA6-4515R
42	52.37	10 x 3.3 12 x 3.3	2-M8 2-M8	12	575	581	58.6	59.3		1.90 1.75	MBSA6-1545L MBSB6-1545L

When installing products produced in B7 style (ring type), always secure the gears onto the mounting base with taper pins to absorb the rotational loads. It is dangerous to secure with bolts only.

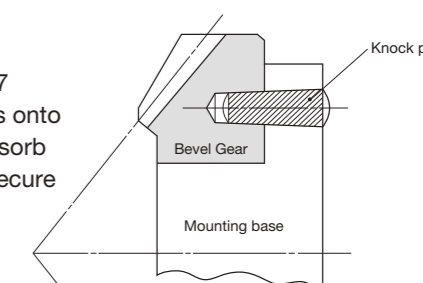





Specifications	
Precision grade	JIS B 1704: 1978 grade 4
Gear teeth	Gleason
Pressure angle	20°
Helix angle	35°*
Material	S45C
Heat treatment	Gear teeth induction hardened **
Tooth hardness	50 to 60HRC
Surface treatment	Black oxide coating

\* 6015R and 1560L of SBS1.5 and 2 are 39°.  
 \*\* Due to the gear teeth being induction hardened, no secondary operations can be performed on tooth areas including the bottom land (approx. 2 to 3 mm).

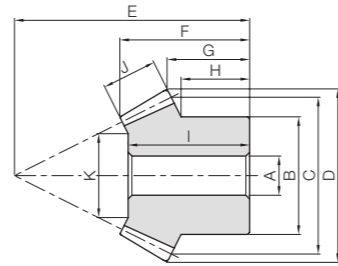

B3

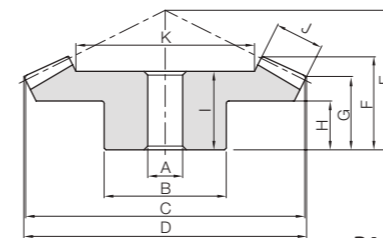

B4

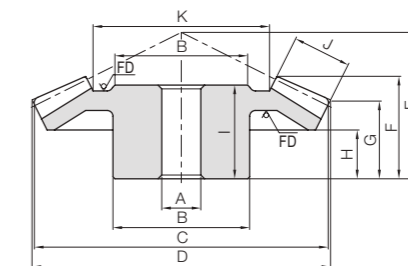

B5

\* FD has a forged finish surface.

Catalog Number	Gear Ratio	Module	No. of teeth	Direction of spiral	Shape	Bore		Pitch dia.	Outside dia.	Mounting distance	Total length		Crown to back
						A	B				C	D	
SBS2-4515R SBS2-1545L	3	m2	45	R	B4	12	40	90	90.67	40	30.29	26.01	
15			L	B3	10	24	30	34.78	60	29.66	15.8		
SBS2.5-4515R SBS2.5-1545L		m2.5	45	R	B4	15	50	112.5	113.32	50	38.25	32.47	
15			L	B3	12	30	37.5	43.36	75	38.27	19.73		
SBS3-4515R SBS3-1545L		m3	45	R	B4	20	60	135	135.99	55	40.59	33.98	
15			L	B3	15	38	45	52.08	90	44.98	23.68		
SBS4-4515R SBS4-1545L	m4	45	R	B5	20	80	180	181.3	70	50.62	41.95		
15		L	B3	16	50	60	69.3	115	54.37	26.55			
SBS5-4515R SBS5-1545L	m5	45	R	B5	30	90	225	226.61	75	50.05	39.92		
15		L	B3	20	60	75	86.55	145	66.89	34.43			
SBS1.5-6015R SBS1.5-1560L	4	m1.5	60	R	B4	12	60	90	90.36	32	24.08	21.48	
15			L	B3	8	18	22.5	26.09	56	22.95	11.45		
SBS2-6015R SBS2-1560L		m2	60	R	B4	15	80	120	120.46	42	31.5	27.91	
15			L	B3	10	24	30	34.68	75	30.94	15.58		
SBS2.5-6015R SBS2.5-1560L		m2.5	60	R	B4	20	100	150	150.5	53	39.68	35.24	
15			L	B3	12	30	37.5	44.16	94	38.9	19.83		
SBS3-6015R SBS3-1560L	m3	60	R	B4	20	120	180	180.57	64	47.61	42.64		
15		L	B3	15	38	45	52.64	112	44.01	22.96			

[Caution on Product Characteristics] ① The bore may slightly vary due to the effect of heat treatment. When using with the listed bore diameter, you may need to ream the bore prior to use.

Product Precautions



Page 342

### ■ Mating surface of spiral bevel gears

Spiral bevel gears have convex and concave tooth surfaces. If the direction of rotation of the drive gear differs, the meshing tooth surface will also change. The table on the right shows how to view the convex and concave tooth surfaces and the meshing tooth surface with respect to the direction of rotation of the drive gear.

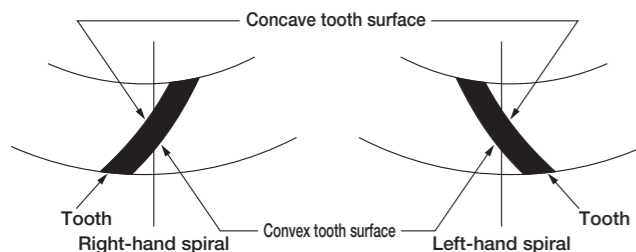

#### For right-hand drive gear

Direction of rotation of drive gear NOTE 1	Meshing tooth surface	
	Right-hand drive gear	Left-hand driven gear
Clockwise	Convex tooth surface	Concave tooth surface
Counterclockwise	Concave tooth surface	Convex tooth surface

#### For left-hand drive gear

Direction of rotation of drive gear NOTE 1	Meshing tooth surface	
	Left-hand drive gear	Right-hand driven gear
Clockwise	Concave tooth surface	Convex tooth surface
Counterclockwise	Convex tooth surface	Concave tooth surface

[NOTE 1] The direction of rotation in the table is as seen from the hub of the gear.

### ■ The force applied to the teeth of the spiral bevel gear

The table below shows, for spiral bevel gears with an axis angle of  $\Sigma = 90^\circ$ , pressure angle of  $\alpha_n = 20^\circ$  and spiral angle of  $\beta_m = 35^\circ$ , the magnitudes of the axial force  $F_x$  and radial force  $F_r$  where the tangential force  $F_t$  at the center of the tooth width is 100.

Thrust force  $F_x$   
Radial force  $F_r$  value

#### (1) Force applied to pinion

Meshing tooth surface	Gear Ratio $z_2/z_1$						
	1.0	1.5	2.0	2.5	3.0	4.0	5.0
Concave tooth surface	80.9	82.9	82.5	81.5	80.5	78.7	77.4
Convex tooth surface	-18.1	-1.9	8.4	15.2	20.0	26.1	29.8
Concave tooth surface	80.9	75.8	71.1	67.3	64.3	60.1	57.3
Convex tooth surface	-18.1	-33.6	-42.8	-48.5	-52.4	-57.2	-59.9
Concave tooth surface	80.9	82.9	82.5	81.5	80.5	78.7	77.4
Convex tooth surface	-18.1	-1.9	8.4	15.2	20.0	26.1	29.8

#### (2) Force applied to gear

Meshing tooth surface	Gear Ratio $z_2/z_1$						
	1.0	1.5	2.0	2.5	3.0	4.0	5.0
Concave tooth surface	80.9	75.8	71.1	67.3	64.3	60.1	57.3
Convex tooth surface	-18.1	-33.6	-42.8	-48.5	-52.4	-57.2	-59.9
Concave tooth surface	80.9	82.9	82.5	81.5	80.5	78.7	77.4
Convex tooth surface	-18.1	-1.9	8.4	15.2	20.0	26.1	29.8



Specifications	
Precision grade	JIS B 1704: 1978 grade 3
Gear teeth	Gleason
Pressure angle	20°
Material	S45C
Heat treatment	—
Tooth hardness	(less than 194HB)
Surface treatment	Black oxide coating

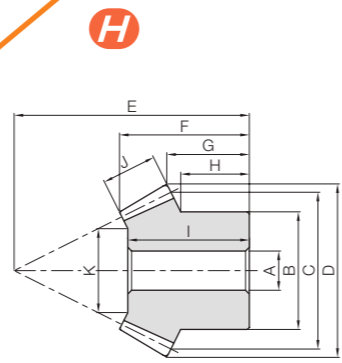

B3

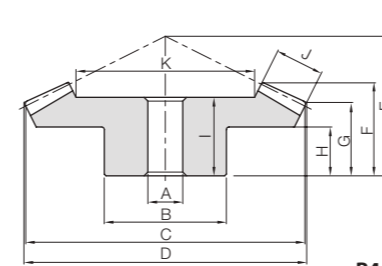

B4

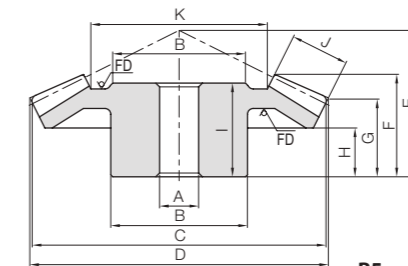

B5

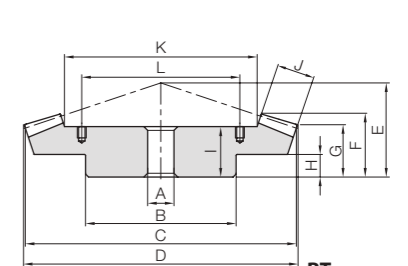

BT

\* FD has a forged finish surface.

**H** To order Hardened Plus, please specify Catalog No. + H. Example: SB1.5-3020H

Catalog Number	Gear Ratio	Module	No. of teeth	Shape	Bore		Hub dia.		Pitch dia.	Outside dia.	Mounting distance	Total length	Crown to back	Hub width
					A <sub>H7</sub>	B	C	D						
<b>SB1.5-3020</b> <b>SB1.5-2030</b>	1.5	m1.5	30	B4	10	30	45	46.24	28	18.53	13.93	8		
20			B3	8	25	30	33.13	33	18.63	11.54	8.83			
<b>SB2-3020</b> <b>SB2-2030</b>		m2	30	B4	10	35	60	61.65	40	26.87	21.24	15		
20			B3	10	30	40	44.18	45	25.06	16.39	11.67			
<b>SB2.5-3020</b> <b>SB2.5-2030</b>		m2.5	30	B4	15	45	75	77.07	50	34.22	26.55	18		
20			B3	12	35	50	55.22	55	31.06	19.24	12.5			
<b>SB3-3020</b> <b>SB3-2030</b>		m3	30	B4	15	50	90	92.48	55	35.56	26.86	17		
20			B3	15	45	60	66.27	70	40.48	27.09	20			
<b>SB4-3020</b> <b>SB4-2030</b>		m4	30	B4	20	70	120	123.3	75	47.71	37.48	25		
20			B3	15	60	80	88.32	90	48.53	32.77	23.33			
<b>SB5-3020</b> <b>SB5-2030</b>	m5	30	B4	25	90	150	154.13	90	58.45	43.1	24			
20		B3	20	80	100	110.45	110	62.11	38.48	28.33				
<b>SB1.5-3015</b> <b>SB1.5-1530</b>	2	m1.5	30	B4	8	25	45	45.88	25	17.85	14.63	9		
15			B3	6	16	22.5	26.11	32	17.23	10.4	7.88			
<b>SB2-3015</b> <b>SB2-1530</b>		m2	30	B4	10	30	60	61.17	31	21.6	17.17	10		
15			B3	8	22	30	34.81	40	20.59	11.2	8			
<b>SB2.5-3015</b> <b>SB2.5-1530</b>		m2.5	30	B4	15	40	75	76.46	40	28.75	22.71	15		
15			B3	12	30	37.5	43.51	55	31.81	19.7	15.63			
<b>SB3-3015</b> <b>SB3-1530</b>		m3	30	B4	16	50	90	91.76	50	37.31	29.26	18		
15			B3	12	35	45	52.22	70	43.88	26.8	22.5			
<b>SB4-3015</b> <b>SB4-1530</b>		m4	30	B4	20	60	120	122.34	60	42.4	32.34	20		
15			B3	16	50	60	69.62	85	48.74	27.41	22.5			
<b>SB5-3015</b> <b>SB5-1530</b>	m5	30	B5	20	70	150	152.93	75	52.5	40.43	25			
15		B3	20	60	75	87.03	110	63.61	38.01	31.25				
<b>SB6-3015</b> <b>SB6-1530</b>	m6	30	B5	25	80	180	183.5	90	62.56	48.49	28			
15		B3	25	70	90	104.44	125	68.48	38.6	30				
<b>SB2.5-3618</b> <b>SB2.5-1836</b>	2	m2.5	36	B4	15	55	90	91.46	43	28.52	21.96	13		
18			B3	12	38	45	51.01	64	34.27	20.5	17.25			
<b>SB3-3618</b> <b>SB3-1836</b>		m3	36	B4	20	60	108	109.76	52	34.95	26.76	17		
18			B3	16	46	54	61.22	75	40.01	22.8	19			
<b>SB4-3618</b> <b>SB4-1836</b>		m4	36	B4	20	70	144	146.34	72	49	38.34	25		
18			B3	20	60	72	81.62	100	52.77	30.41	25			
<b>SB1-4020</b> <b>SB1-2040</b>	2	m1	40	B4	8	25	40	40.59	22	15.07	12.59	8		
20			B3	6	16	20	22.41	28	13.78	8.6	7			
<b>SB1.25-4020</b> <b>SB1.25-2040</b>		m1.25	40	B4	10	32	50	50.73	27	18.54	15.23	10		
20			B3	8	22	25	28.01	36	18.66	11.75	10.25			
<b>SB1.5-4020</b> <b>SB1.5-2040</b>		m1.5	40	B4	10	38	60	60.88	35	25.01	20.88	15		
20			B3	8	25	30	33.61	46	25.54	16.9	14.75			
<b>SB2-4020</b> <b>SB2-2040</b>		m2	40	B4	12	40	80	81.17	45	32.37	26.17	18		
20			B3	12	32	40	44.81	60	34.16	21.2	18			
<b>SB2.5-4020</b> <b>SB2.5-2040</b>		m2.5	40	B4	15	50	100	101.46	55	39.73	31.46	20		
20			B3	12	40	50	56.01	75	43.78	26.5	22.5			
<b>SB3-4020</b> <b>SB3-2040</b>		m3	40	B4	20	60	120	121.76	65	45.85	36.76	24		
20			B3	16	50	60	67.22	90	50.81	31.8	27.5			
<b>SB4-4020</b> <b>SB4-2040</b>		m4	40	B4	20	70	160	162.34	80	53.92	42.34	28		
20			B3	20	60	80	89.62	120	66.59	42.41	35			
<b>SB5-4020</b> <b>SB5-2040</b>		m5	40	B5	25	100	200	202.93	90	55.33	42.93	26		
20			B3	20	80	100	112.03	140	68.92	43.01	35			
<b>SB6-4020</b> <b>SB6-2040</b>	m6	40	B5	25	85	240	243.52	105	65.05	48.52	28			
20		B3	25	90	120	134.44	160	78.16	43.6	32.5				
<b>SBY8-4020</b> <b>SBY8-2040</b>	m8	40	BT	35	180	320	324.69	130	75.36	54.69	25			
20		B3	30	120	160	179.25	210	98	54.81	40				

Hole length	Face width	Holding surface dia.	Allowable torque						Backlash (mm)	Weight (kg)	Catalog Number
			Bending strength		Surface durability		Surface durability <b>H</b>				
			N·m	kgf·m	N·m	kgf·m	N·m	kgf·m			
16	9	27.37	5.82	0.59	0.65	0.07	2.78	0.28	0.05~0.15	0.12	<b>SB1.5-3020</b>
17	9	17.05	4.04	0.41	0.44	0.04	1.86	0.19	0.05~0.15	0.063	<b>SB1.5-2030</b>
23	11	37.56	13.1	1.33	1.52	0.16	6.37	0.65	0.06~0.16	0.26	<b>SB2-3020</b>
22	11	21.34	9.07	0.92	1.01	0.10	4.25	0.43	0.06~0.16	0.14	<b>SB2-2030</b>
30	15	45.61	26.9	2.75	3.21	0.33	13.3	1.36	0.07~0.17	0.55	<b>SB2.5-3020</b>
28	15	27.42	18.7	1.91	2.14	0.22	8.86	0.90	0.07~0.17	0.25	<b>SB2.5-2030</b>
31	17	57.14	44.9	4.58	5.45	0.56	22.4	2.29	0.08~0.18	0.83	<b>SB3-3020</b>
37	17	34.71	31.2	3.18	3.63	0.37	14.9	1.52	0.08~0.18	0.50	<b>SB3-2030</b>
40	20	78.59	98.2	10.0	12.3	1.25	49.8	5.07	0.12~0.27	1.91	<b>SB4-3020</b>
43	20	46.89	68.1	6.95	8.20	0.84	33.2	3.38	0.12~0.27	1.10	<b>SB4-2030</b>
50	30	91.22	215	22.0	27.6	2.81	110	11.2	0.14~0.34	4.13	<b>SB5-3020</b>
56	30	54.83	150	15.3	18.4	1.87	73.5	7.49	0.14~0.34	2.34	<b>SB5-2030</b>
15	8	28.36	5.02	0.51	0.47	0.05	2.02	0.21	0.05~0.15	0.10	<b>SB1.5-3015</b>
15.5	8	10.72	2.60	0.26	0.24	0.02	1.01	0.10	0.05~0.15	0.028	<b>SB1.5-1530</b>
18	11	37.4	12.1	1.24	1.18	0.12	4.96	0.51	0.06~0.16	0.21	<b>SB2-3015</b>
19	11	16.81	6.28	0.64	0.59	0.06	2.48	0.25	0.06~0.16	0.064	<b>SB2-1530</b>
24	15	44.21	24.9	2.54	2.48	0.25	10.3	1.05	0.07~0.17	0.41	<b>SB2.5-3015</b>
29	15	16.42	12.9	1.32	1.24	0.13	5.16	0.53	0.07~0.17	0.15	<b>SB2.5-1530</b>
30	20	47.78	45.6	4.65	4.60	0.47	19.1	1.94	0.08~0.18	0.83	<b>SB3-3015</b>
41	20	19.56	23.6	2.41	2.30	0.23	9.53	0.97	0.08~0.18	0.31	<b>SB3-1530</b>
36	25	70.1	104	10.7	10.9	1.11	44.4	4.53	0.12~0.27	1.64	<b>SB4-3015</b>
46	25	32.2	54.0	5.51	5.43	0.55	22.2	2.26	0.12~0.27	0.66	<b>SB4-1530</b>
48	30	90.41	199	20.3	21.3	2.17	85.7	8.74	0.14~0.34	2.72	<b>SB5-3015</b>
58	30	32.83	103	10.5	10.6	1.09	42.9	4.37	0.14~0.34	1.28	<b>SB5-1530</b>
57	35	109.74	336	34.2	36.9	3.77	147	15.0	0.16~0.36	4.75	<b>SB6-3015</b>
63	35	45.47	174	17.7	18.5	1.88	73.5	7.50	0.16~0.36	1.94	<b>SB6-1530</b>
24	16	57.72	35.9	3.66	4.08	0.42	16.8	1.72	0.07~0.17	0.72	<b>SB2.5-3618</b>
32	16	25.44	18.1	1.84	2.04	0.21	8.42	0.86	0.07~0.17	0.27	<b>SB2.5-1836</b>
30	20	68.28	63.7	6.49	7.34	0.75	30.1	3.07	0.08~0.18	1.15	<b>SB3-3618</b>
37	20	28.56	32.0	3.27	3.67	0.37	15.1	1.54	0.08~0.18	0.44	<b>SB3-1836</b>
42	26	91.86	149	15.2	17.7	1.80	71.3	7.27	0.12~0.27	2.66	<b>SB4-3618</b>
49	26	39.72	74.8	7.62	8.85	0.90	35.7	3.64	0.12~0.27	1.04	<b>SB4-1836</b>
12	6	26.58	2.61	0.27	0.29	0.03	1.26	0.13	0.03~0.13	0.068	<b>SB1-4020</b>
12	6	9.17	1.32	0.13	0.15	0.02	0.63	0.065	0.03~0.13	0.019	<b>SB1-2040</b>
16	8	33.61	5.33	0							



Specifications	
Precision grade	JIS B 1704: 1978 grade 3
Gear teeth	Gleason
Pressure angle	20°
Material	S45C
Heat treatment	—
Tooth hardness	(less than 194HB)
Surface treatment	Black oxide coating

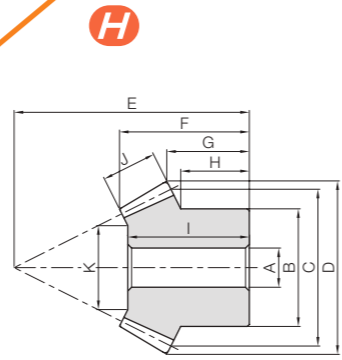

B3

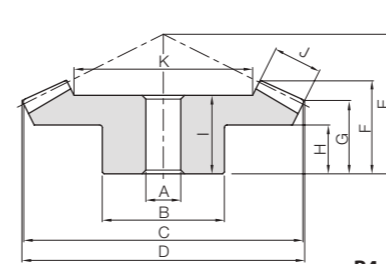

B4

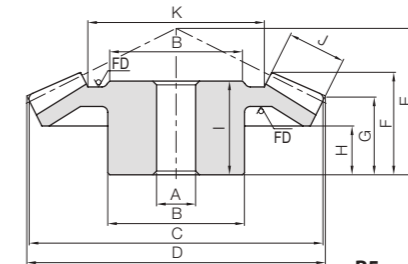

B5

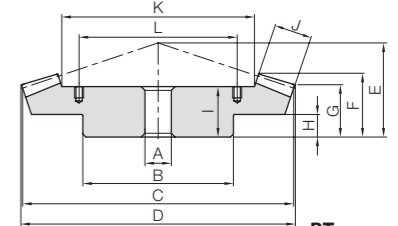

BT

\* FD has a forged finish surface.

**H** To order Hardened Plus, please specify **Catalog No. + H**. Example: **SB1-4518H**

Catalog Number	Gear Ratio	Module	No. of teeth	Shape	Bore	Hub dia.	Pitch dia.	Outside dia.	Mounting distance	Total length	Crown to back	Hub width
					A <sub>H7</sub>	B	C	D	E	F	G	H
<b>SB1-4518</b> <b>SB1-1845</b>	2.5	m1	45	B4	8	30	45	45.46	23	16.95	14.57	10
18			B3	6	15	18	20.57	32	16.34	10.02	8.9	
<b>SB1.5-4518</b> <b>SB1.5-1845</b>		m1.5	45	B4	10	36	67.5	68.18	30	21.1	17.35	10
18			B3	8	23	27	30.86	45	21.97	12.02	10.45	
<b>SB2-4518</b> <b>SB2-1845</b>		m2	45	B4	12	48	90	90.91	40	27.91	23.14	15
18			B3	10	32	36	41.15	60	28.69	16.03	14.2	
<b>SB2.5-4518</b> <b>SB2.5-1845</b>		m2.5	45	B4	15	55	112.5	113.64	50	35.06	28.92	18
18			B3	12	40	45	51.44	72	33.31	17.04	14.75	
<b>SB3-4518</b> <b>SB3-1845</b>		m3	45	B4	20	65	135	136.37	60	41.86	34.71	22
18			B3	16	48	54	61.72	85	38.04	19.05	16.3	
<b>SB4-4518</b> <b>SB4-1845</b>	m4	45	B4	20	80	180	181.82	75	51.16	41.28	24	
18		B3	20	62	72	82.3	110	48.28	22.06	18		
<b>SB5-4518</b> <b>SB5-1845</b>	m5	45	B4	25	100	225	227.28	90	59.43	47.85	28	
18		B3	20	80	90	102.87	135	55.82	25.07	20.5		
<b>SB1-4515</b> <b>SB1-1545</b>	3	m1	45	B4	8	30	45	45.37	17	11.77	10.06	5
15			B3	6	12	15	17.67	29	12.51	6.95	6	
<b>SB1.25-4515</b> <b>SB1.25-1545</b>		m1.25	45	B4	10	34	56.25	56.72	21	14.61	12.33	6
15			B3	8	15	18.75	22.09	36	15.85	8.43	7.25	
<b>SB1.5-4515</b> <b>SB1.5-1545</b>		m1.5	45	B4	10	36	67.5	68.06	28	20.44	17.59	11
15			B3	8	18	22.5	26.54	47	23.19	13.92	12.5	
<b>SB2-4515</b> <b>SB2-1545</b>		m2	45	B4	12	40	90	90.75	40	30.4	26.12	17
15			B3	10	24	30	35.35	60	29.8	15.89	14	
<b>SB2.5-4515</b> <b>SB2.5-1545</b>		m2.5	45	B4	15	50	112.5	113.43	50	38.35	32.65	22
15			B3	12	30	37.5	44.18	75	38.41	19.86	17.5	
<b>SB3-4515</b> <b>SB3-1545</b>	m3	45	B4	20	60	135	136.12	55	40.74	34.18	20	
15		B3	15	38	45	53.02	90	45.17	23.84	21.33		
<b>SB4-4515</b> <b>SB4-1545</b>	m4	45	B5	20	80	180	181.5	70	50.79	42.24	24	
15		B3	16	50	60	70.69	115	54.6	26.78	23.33		
<b>SB5-4515</b> <b>SB5-1545</b>	m5	45	B5	25	90	225	226.87	75	50.28	40.3	20	
15		B3	20	60	75	88.37	145	67.19	34.73	30		
<b>SB6-4515</b> <b>SB6-1545</b>	m6	45	BT	30	160	270	272.24	100	72.62	58.36	30	
15		B3	25	70	90	106.03	175	89.04	42.67	36.67		
<b>SBY8-4515</b> <b>SBY8-1545</b>	m8	45	BT	35	200	360	362.99	125	83.74	69.49	30	
15		B3	30	100	120	141.39	230	99.93	53.56	46.67		

[Caution on Product Characteristics] ① For the handling conveniences, the BT series has the tapped holes on the holding surface. Please see the table on the right for L and tap sizes.

[Caution on Secondary Operations] ① See Page 22 for more details on Hardened Plus (H Series and HJ Series).

Hole length	Face width	Holding surface dia.	Allowable torque						Backlash (mm)	Weight (kg)	Catalog Number
			Bending strength		Surface durability		Surface durability <b>H</b>				
			N·m	kgf·m	N·m	kgf·m	N·m	kgf·m			
15	7	30.73	3.35	0.34	0.35	0.04	1.52	0.15	0.03~0.13	0.11	<b>SB1-4518</b> <b>SB1-1845</b>
15.5		10.31	1.33	0.14	0.14	0.01	0.61	0.062			
18	11	45	11.7	1.19	1.29	0.13	5.39	0.55	0.05~0.15	0.28	<b>SB1.5-4518</b> <b>SB1.5-1845</b>
21		16.51	4.64	0.47	0.51	0.05	2.16	0.22			
25	14	62.24	26.8	2.74	3.05	0.31	12.6	1.29	0.06~0.16	0.65	<b>SB2-4518</b> <b>SB2-1845</b>
27.5		23.11	10.7	1.09	1.22	0.12	5.05	0.52			
31	18	76.53	53.4	5.44	6.20	0.63	25.4	2.59	0.07~0.17	1.23	<b>SB2.5-4518</b> <b>SB2.5-1845</b>
31.5		26.82	21.2	2.16	2.48	0.25	10.2	1.04			
37	21	92.96	90.5	9.23	10.7	1.09	43.5	4.44	0.08~0.18	2.05	<b>SB3-4518</b> <b>SB3-1845</b>
36		33.41	36.0	3.67	4.29	0.44	17.4	1.78			
45	29	122.33	220	22.4	26.8	2.73	107	10.9	0.12~0.27	4.69	<b>SB4-4518</b> <b>SB4-1845</b>
46		45.83	87.3	8.91	10.7	1.09	42.8	4.37			
51	34	156.56	411	41.9	51.8	5.28	202	20.6	0.14~0.34	8.31	<b>SB5-4518</b> <b>SB5-1845</b>
52.5		56.9	164	16.7	20.7	2.11	81.0	8.26			
9	6	32.02	2.84	0.29	0.27	0.027	1.15	0.12	0.03~0.13	0.078	<b>SB1-4515</b> <b>SB1-1545</b>
12		10.05	0.98	0.10	0.09	0.0091	0.38	0.039			
12	8	39.63	5.80	0.59	0.56	0.057	2.38	0.24	0.04~0.14	0.15	<b>SB1.25-4515</b> <b>SB1.25-1545</b>
15		10.9	2.00	0.20	0.19	0.019	0.79	0.081			
17	10	46.58	10.3	1.05	1.02	0.10	4.27	0.44	0.05~0.15	0.25	<b>SB1.5-4515</b> <b>SB1.5-1545</b>
22.5		14.75	3.56	0.36	0.34	0.035	1.42	0.15			
26	15	59.04	26.4	2.69	2.68	0.27	11.1	1.13	0.06~0.16	0.60	<b>SB2-4515</b> <b>SB2-1545</b>
29		19.13	9.10	0.93	0.89	0.091	3.70	0.38			
35	20	72.84	53.6	5.46	5.55	0.57	22.8	2.33	0.07~0.17	1.22	<b>SB2.5-4515</b> <b>SB2.5-1545</b>
37		20.51	18.5	1.89	1.85	0.19	7.61	0.78			
35	23	88.18	90.2	9.20	9.53	0.97	38.9	3.96	0.08~0.18	1.99	<b>SB3-4515</b> <b>SB3-1545</b>
43		22.53	31.2	3.18	3.18	0.32	13.0	1.32			
45	30	118.09	211	21.5	23.0	2.35	92.1	9.40	0.12~0.27	3.89	<b>SB4-4515</b> <b>SB4-1545</b>
52		32.26	72.8	7.43	7.67	0.78	30.7	3.13			
44	35	152.88	394	40.2	44.3	4.52	174	17.7	0.14~0.34	6.10	<b>SB5-4515</b> <b>SB5-1545</b>
65		48.64	136	13.9	14.8	1.51	58.0	5.91			
62	50	169.26	751	76.6	87.0	8.87	337	34.3	0.16~0.36	18.0	<b>SB6-4515</b> <b>SB6-1545</b>
86		49.77	259	26.4	39.9	4.06	112	11.4			
67	50	255.92	1470	150	179	18.3	674	68.8	0.20~0.45	36.4	<b>SBY8-4515</b> <b>SBY8-1545</b>
93		61.77	506	51.6	59.7	6.09	225	22.9			

For the handling conveniences, the products listed in the table below have the tapped holes (180° apart, 2 places) on the holding surface.

Catalog Number	L (mm)	Tap Size
<b>SB6-4515</b>	130	M10, 20mm deep
<b>SBY8-4515</b>	210	M10, 20mm deep



Specifications	
Precision grade	JIS B 1704: 1978 grade 3
Gear teeth	Gleason
Pressure angle	20°
Material	S45C
Heat treatment	—
Tooth hardness	(less than 194HB)
Surface treatment	Black oxide coating

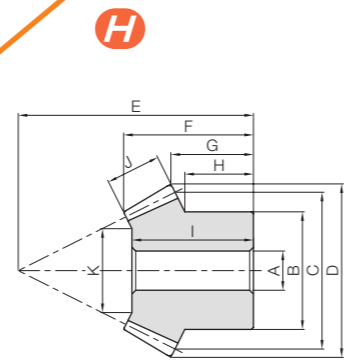

B3

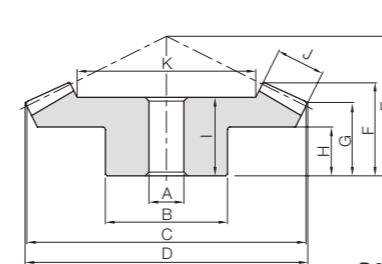

B4

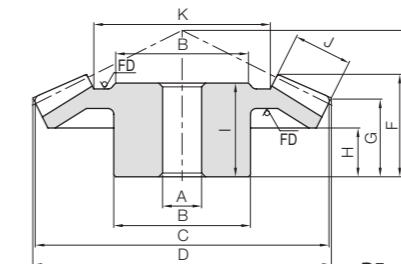

B5

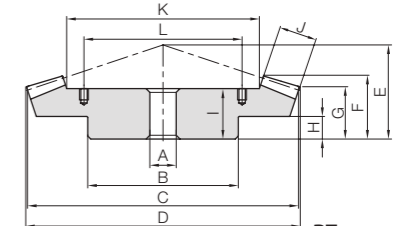

BT

\* FD has a forged finish surface.

**H** To order Hardened Plus, please specify **Catalog No. + H**. Example: **SB1.5-6015H**

Catalog Number	Gear Ratio	Module	No. of teeth	Shape	Bore		Hub dia.		Pitch dia.	Outside dia.	Mounting distance	Total length	Crown to back	Hub width
					A <sub>H7</sub>	B	C	D						
<b>SB1.5-6015</b> <b>SB1.5-1560</b>	4	m1.5	60	B4	12	50	90	90.41	32	24.2	21.58	12		
15			B3	8	18	22.5	26.66	56	23.01	11.52	10.43			
<b>SB2-6015</b> <b>SB2-1560</b>		m2	60	B4	15	60	120	120.55	42	31.6	28.1	16		
15			B3	10	24	30	35.55	75	31.01	15.69	14.25			
<b>SB2.5-6015</b> <b>SB2.5-1560</b>		m2.5	60	B4	20	70	150	150.69	53	40	35.63	20		
15			B3	12	30	37.5	44.44	94	39.02	19.87	18.06			
<b>SB3-6015</b> <b>SB3-1560</b>		m3	60	B4	20	80	180	180.83	64	47.97	43.15	25		
15			B3	15	38	45	53.33	112	44.1	23.04	21.12			
<b>SB4-6015</b> <b>SB4-1560</b>		m4	60	B5	25	85	240	241.1	80	59.2	52.2	36		
15			B3	16	50	60	71.1	150	62.03	31.4	28.75			
<b>SBY5-6015</b> <b>SBY5-1560</b>		m5	60	BT	30	180	300	301.36	80	53.97	45.22	20		
15			B3	25	60	75	88.9	185	75.03	36.74	33.13			
<b>SBY6-6015</b> <b>SBY6-1560</b>	m6	60	BT	35	200	360	361.66	100	68.16	58.31	25			
15		B3	25	75	90	106.66	220	85.17	42.08	38.13				

[Caution on Product Characteristics] ① For the handling conveniences, the BT series has the tapped holes on the holding surface. Please see the table on the right for L and tap sizes.

[Caution on Secondary Operations] ① See Page 22 for more details on Hardened Plus (H Series and HJ Series).

Hole length	Face width	Holding surface dia.	Allowable torque						Backlash (mm)	Weight (kg)	Catalog Number
			Bending strength		Surface durability		Surface durability <b>H</b>				
I	J	K	N·m	kgf·m	N·m	kgf·m	N·m	kgf·m			
21 22.5	12	65.38 15.54	17.3 4.46	1.77 0.45	1.75 0.44	0.18 0.045	7.28 1.82	0.74 0.19	0.05~0.15	0.62 0.043	<b>SB1.5-6015</b> <b>SB1.5-1560</b>
27 30	16	87.02 18.06	41.3 10.6	4.21 1.08	4.30 1.07	0.44 0.11	17.5 4.38	1.79 0.45	0.06~0.16	1.35 0.10	<b>SB2-6015</b> <b>SB2-1560</b>
34 37.5	20	108.64 20.57	80.2 20.6	8.18 2.10	8.54 2.13	0.87 0.22	34.6 8.66	3.53 0.88	0.07~0.17	2.51 0.21	<b>SB2.5-6015</b> <b>SB2.5-1560</b>
41 43	22	134.4 31.58	130 33.5	13.3 3.42	14.2 3.54	1.44 0.36	56.8 14.2	5.79 1.45	0.08~0.18	4.16 0.36	<b>SB3-6015</b> <b>SB3-1560</b>
53 60	32	174.03 36.12	328 84.5	33.5 8.62	37.0 9.24	3.77 0.94	145 36.2	14.8 3.70	0.12~0.27	6.00 0.91	<b>SB4-6015</b> <b>SB4-1560</b>
45 73	40	218.79 49.15	642 165	65.4 16.8	74.4 18.6	7.59 1.90	286 71.4	29.1 7.28	0.14~0.34	17.5 1.58	<b>SBY5-6015</b> <b>SBY5-1560</b>
56 82	45	267.73 54.92	1050 270	107 27.5	126 31.5	12.8 3.21	475 119	48.4 12.1	0.16~0.36	30.7 2.83	<b>SBY6-6015</b> <b>SBY6-1560</b>

For the handling conveniences, the products listed in the table below have the tapped holes (180° apart, 2 places) on the holding surface.

Catalog Number	L (mm)	Tap Size
<b>SBY5-6015</b>	160	M10, 20mm deep
<b>SBY6-6015</b>	220	M10, 20mm deep

SB Module 1.5~3  
**Steel Bevel Gears & Pinion Shafts** *NEW*



Specifications	
Precision grade	JIS B 1704: 1978 grade 3
Gear teeth	Gleason
Pressure angle	20°
Material	S45C
Heat treatment	—
Tooth hardness	(less than 194HB)*
Surface treatment	Black oxide coating

\* B8 products use thermal refined materials, so the teeth hardness is 200 to 270 HB.

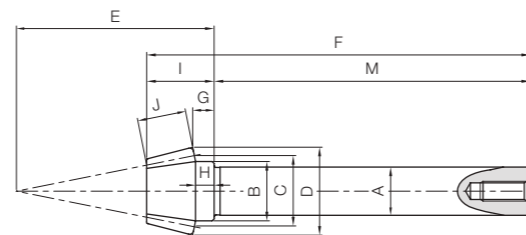

B8

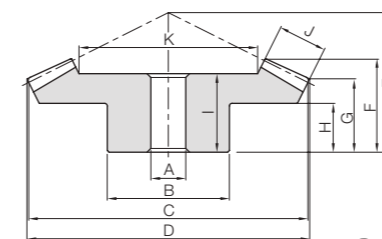

B4

**H** To order Hardened Plus, please specify **Catalog No. + H**. Example: **SB1.5-6012H**

Catalog Number	Gear Ratio	Module	No. of teeth	Shape	Bore/Shaft Dia.		Hub dia.	Pitch dia.	Outside dia.	Mounting distance	Total length	Crown to back	Hub width	Length of bore and shaft
					A <sub>H7</sub> (bore)	B								
<b>SB1.5-6012</b> <b>SB1.5-1260</b>	5	m1.5	60	B4	12	50	90	90.33	30	23.89	21.82	12	21	
12			B8	12.2	15	18	22.24	50	97.06	5.42	4.7	17.06		
<b>SB2-6012</b> <b>SB2-1260</b>		m2	60	B4	15	60	120	120.43	40	31.85	29.09	16	27	
12			B8	15.2	20	24	29.65	66	117.08	6.56	5.6	22.08		
<b>SB2.5-6012</b> <b>SB2.5-1260</b>		m2.5	60	B4	20	70	150	150.54	50	39.81	36.36	20	34	
12			B8	20.2	25	30	37.06	83	143.1	8.7	7.5	28.1		
<b>SB3-6012</b> <b>SB3-1260</b>		m3	60	B4	20	80	180	180.65	60	47.43	43.64	25	41	
12			B8	25.25	30	36	44.48	100	172.19	10.85	9.4	32.19		

[Caution on Secondary Operations] ① See Page 22 for more details on Hardened Plus (H Series and HJ Series).

Face width	Holding surface dia.	Length of shaft	Socket head screw Size	Allowable torque						Backlash (mm)	Weight (kg)	Catalog Number
				Bending strength		Surface durability		Surface durability <b>H</b>				
J	K	M		N·m	kgf·m	N·m	kgf·m	N·m	kgf·m			
12	65.52	—	—	18.0	1.83	1.41	0.14	5.85	0.60	0.05~0.15	0.62	<b>SB1.5-6012</b> <b>SB1.5-1260</b>
16	86.96	—	—	42.6	4.34	3.43	0.35	14.1	1.44	0.06~0.16	1.34	<b>SB2-6012</b> <b>SB2-1260</b>
20	108.8	—	—	83.2	8.48	6.85	0.70	27.9	2.84	0.07~0.17	2.54	<b>SB2.5-6012</b> <b>SB2.5-1260</b>
22	134.73	—	—	135	13.8	11.4	1.16	45.7	4.66	0.08~0.18	4.18	<b>SB3-6012</b> <b>SB3-1260</b>



Specifications	
Precision grade	JIS B 1704: 1978 grade 3
Gear teeth	Gleason
Pressure angle	20°
Material	SUS303
Heat treatment	—
Tooth hardness	(less than 187HB)

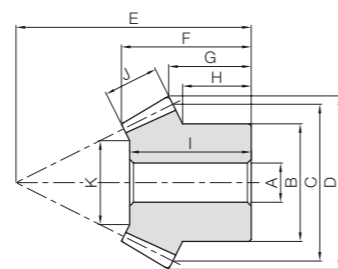

B3

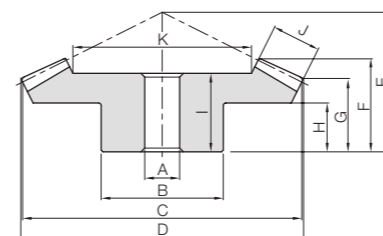

B4

Catalog Number	Gear Ratio	Module	No. of teeth	Shape	Bore		Hub dia.	Pitch dia.	Outside dia.	Mounting distance	Total length		Hub width
					A <sub>H7</sub>	B					C	D	
<b>SUB1.5-3020</b> <b>SUB1.5-2030</b>	1.5	m1.5	30	B4	10	30	45	46.24	28	18.53	13.93	8	
20			B3	8	25	30	33.13	33	18.63	11.54	8.83		
<b>SUB2-3020</b> <b>SUB2-2030</b>		m2	30	B4	10	35	60	61.65	40	26.87	21.24	15	
20			B3	10	35	40	44.18	45	25.06	16.39	13.33		
<b>SUB2.5-3020</b> <b>SUB2.5-2030</b>		m2.5	30	B4	15	45	75	77.07	50	34.22	26.55	18	
20			B3	12	40	50	55.22	55	31.06	19.24	14.16		
<b>SUB3-3020</b> <b>SUB3-2030</b>	m3	30	B4	15	60	90	92.48	55	35.56	26.86	17		
20		B3	15	50	60	66.27	70	40.48	27.09	21.66			
<b>SUB1.5-4020</b> <b>SUB1.5-2040</b>	2	m1.5	40	B4	10	38	60	60.88	35	25.01	20.88	15	
20			B3	8	25	30	33.61	46	25.54	16.9	14.75		
<b>SUB2-4020</b> <b>SUB2-2040</b>		m2	40	B4	12	50	80	81.17	45	32.37	26.17	18	
20			B3	12	32	40	44.81	60	34.16	21.2	18		
<b>SUB2.5-4020</b> <b>SUB2.5-2040</b>		m2.5	40	B4	15	60	100	101.46	55	39.73	31.46	20	
20			B3	12	40	50	56.01	75	43.78	26.5	22.5		
<b>SUB3-4020</b> <b>SUB3-2040</b>	m3	40	B4	20	70	120	121.76	65	45.85	36.76	24		
20		B3	16	50	60	67.22	90	50.81	31.8	27.5			
<b>SUB1.5-4515</b> <b>SUB1.5-1545</b>	3	m1.5	45	B4	10	36	67.5	68.06	28	20.44	17.59	11	
15			B3	8	18	22.5	26.54	47	23.19	13.92	12.5		
<b>SUB2-4515</b> <b>SUB2-1545</b>		m2	45	B4	12	60	90	90.75	40	30.4	26.12	17	
15			B3	10	24	30	35.35	60	29.8	15.89	14		
<b>SUB2.5-4515</b> <b>SUB2.5-1545</b>		m2.5	45	B4	15	60	112.5	113.43	50	38.35	32.65	22	
15			B3	12	30	37.5	44.18	75	38.41	19.86	17.5		
<b>SUB3-4515</b> <b>SUB3-1545</b>	m3	45	B4	20	80	135	136.12	55	40.74	34.18	20		
15		B3	15	38	45	53.02	90	45.17	23.84	21.33			

Hole length	Face width	Holding surface dia.	Allowable torque (N·m)		Allowable torque (kgf·m)		Backlash (mm)	Weight (kg)	Catalog Number
			Bending strength	Surface durability	Bending strength	Surface durability			
16 17	9	27.37	3.22	0.46	0.33	0.047	0.05~0.15	0.12 0.064	<b>SUB1.5-3020</b> <b>SUB1.5-2030</b>
23 22		17.05	2.23	0.31	0.23	0.032			
30 28	15	37.56	7.22	1.08	0.74	0.11	0.06~0.16	0.27 0.16	<b>SUB2-3020</b> <b>SUB2-2030</b>
31 37		21.34	5.01	0.72	0.51	0.074			
38 47	22	73.81	44.4	7.19	4.53	0.73	0.08~0.18	1.89 0.70	<b>SUB3-4020</b> <b>SUB3-2040</b>
41 43		24.56	13.6	2.15	1.39	0.22			
22 24	10	39.64	5.23	0.79	0.53	0.081	0.05~0.15	0.27 0.090	<b>SUB1.5-4020</b> <b>SUB1.5-2040</b>
27 32		17.28	2.64	0.40	0.27	0.040			
35 41	20	60.28	27.1	4.29	2.76	0.44	0.07~0.17	1.24 0.41	<b>SUB2.5-4020</b> <b>SUB2.5-2040</b>
38 47		24.56	13.6	2.15	1.39	0.22			
26 29	15	59.04	14.6	1.90	1.49	0.19	0.06~0.16	0.82 0.097	<b>SUB2-4515</b> <b>SUB2-1545</b>
35 37		19.13	5.03	0.63	0.51	0.065			
35 37	20	72.84	29.6	3.94	3.02	0.40	0.07~0.17	1.38 0.19	<b>SUB2.5-4515</b> <b>SUB2.5-1545</b>
43		20.51	10.2	1.31	1.04	0.13			
35 43	23	88.18	49.9	6.77	5.09	0.69	0.08~0.18	2.36 0.34	<b>SUB3-4515</b> <b>SUB3-1545</b>
43		22.53	17.2	2.26	1.76	0.23			





Specifications	
Precision grade	JIS B 1704: 1978 grade 4*
Gear teeth	Gleason
Pressure angle	20°
Material	MC901
Heat treatment	—
Tooth hardness	(115 to 120HRR)

\* The precision grade is equivalent to the value shown in the table.

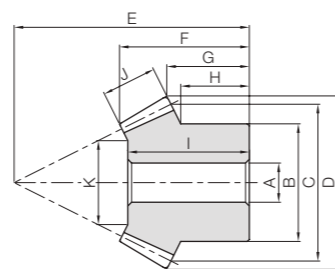

B3

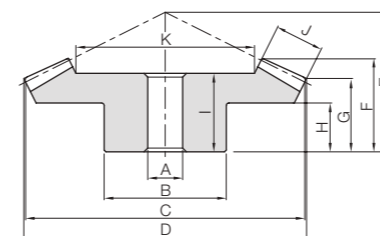

B4

Catalog Number	Gear Ratio	Module	No. of teeth	Shape	Bore		Pitch dia.	Outside dia.	Mounting distance	Total length	Crown to back		Hub width
					A	B					C	D	
<b>PB1.5-3020</b>	1.5	<b>m1.5</b>	30	B4	10	30	45	46.24	28	18.53	13.93	8	
<b>PB1.5-2030</b>			20	B3	8	25	30	33.13	33	18.63	11.54	8.83	
<b>PB2-3020</b>		<b>m2</b>	30	B4	10	35	60	61.65	40	26.87	21.24	15	
<b>PB2-2030</b>			20	B3	10	35	40	44.18	45	25.06	16.39	13.33	
<b>PB1-4020</b>	2	<b>m1</b>	40	B4	8	25	40	40.59	22	15.07	12.59	8	
<b>PB1-2040</b>			20	B3	6	16	20	22.41	28	13.78	8.6	7	
<b>PB1.25-4020</b>		<b>m1.25</b>	40	B4	10	32	50	50.73	27	18.54	15.23	10	
<b>PB1.25-2040</b>			20	B3	8	22	25	28.01	36	18.66	11.75	10.25	
<b>PB1.5-4020</b>		<b>m1.5</b>	40	B4	10	38	60	60.88	35	25.01	20.88	15	
<b>PB1.5-2040</b>			20	B3	8	25	30	33.61	46	25.54	16.9	14.75	
<b>PB2-4020</b>		<b>m2</b>	40	B4	12	40	80	81.17	45	32.37	26.17	18	
<b>PB2-2040</b>			20	B3	12	32	40	44.81	60	34.16	21.2	18	
<b>PB1.5-4515</b>	3	<b>m1.5</b>	45	B4	10	40	67.5	68.06	28	20.44	17.59	11	
<b>PB1.5-1545</b>			15	B3	8	18	22.5	26.54	47	23.19	13.92	12.5	
<b>PB2-4515</b>		<b>m2</b>	45	B4	12	60	90	90.75	40	30.4	26.12	17	
<b>PB2-1545</b>			15	B3	10	24	30	35.35	60	29.8	15.89	14	

[Caution on Product Characteristics] ① To reduce heat generation, it is recommended to mate plastic gears with steel gears.

Hole length	Face width	Holding surface dia.	Allowable torque (N·m)		Allowable torque (kgf·m)		Backlash (mm)	Weight (kg)	Catalog Number
			Bending strength	Surface durability	Bending strength	Surface durability			
16	9	27.37	1.61	—	0.16	—	0~0.25	0.018	<b>PB1.5-3020</b>
17		17.05	0.87	0.089	—	0.0093			
23	11	37.56	3.65	—	0.37	—	0~0.26	0.039	<b>PB2-3020</b>
22		21.34	1.97	0.20	—	0.024			
12	6	26.58	0.74	—	0.075	—	0~0.23	0.010	<b>PB1-4020</b>
12		9.17	0.28	0.028	—	0.0029			
16	8	33.61	1.50	—	0.15	—	0~0.24	0.021	<b>PB1.25-4020</b>
17		13.22	0.56	0.058	—	0.0068			
22	10	39.64	2.66	—	0.27	—	0~0.25	0.039	<b>PB1.5-4020</b>
24		17.28	1.00	0.10	—	0.013			
27	15	48.46	6.72	—	0.69	—	0~0.26	0.076	<b>PB2-4020</b>
32		20.92	2.52	0.26	—	0.028			
17	10	46.58	3.18	—	0.32	—	0~0.25	0.040	<b>PB1.5-4515</b>
22.5		14.75	0.68	0.070	—	0.0061			
26	15	59.04	8.07	—	0.82	—	0~0.26	0.12	<b>PB2-4515</b>
29		19.13	1.73	0.18	—	0.014			

\* In regard to MC Nylon gears, other materials are available for plastic gears, including Ultra High Molecular Weight Polyethylene (U-PE), which has excellent abrasion resistance and resin conforming to the Plastic Implementation Measure (PIM). A single piece order is acceptable and will be produced as a custom-made gear. Please see Page 26 for more details on quotations and orders.





Specifications	
Precision grade	JIS B 1704: 1978 grade 6
Gear teeth	Gleason
Pressure angle	20°
Material	Duracon (R) (M90-44)
Heat treatment	—
Tooth hardness	(110 to 120HRR)

\* "Duracon (R)" is a registered trademark of Polyplastics Co., Ltd. in Japan as well as other countries.

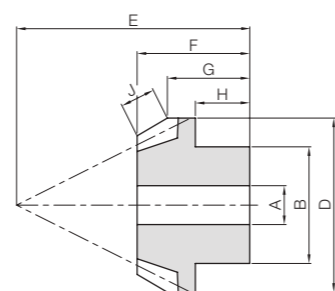

B1

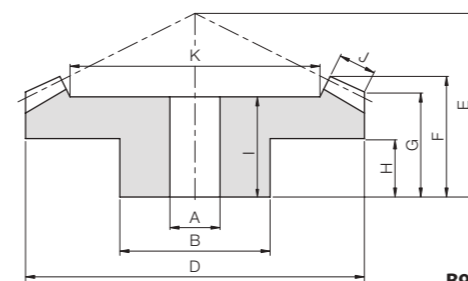

B9

Catalog Number	Gear Ratio	Module	No. of teeth	Shape	Bore		Pitch dia.	Outside dia.	Mounting distance	Total length		Crown to back
					A	B				F	G	
<b>DB0.5-4020</b> <b>DB0.5-2040</b>	2	<b>m0.5</b>	40	B9	4	12	20	20.29	12	8.33	7.29	
20			B1	3	8	10	11.2	16	8.46	6.3		
<b>DB0.8-4020</b> <b>DB0.8-2040</b>		<b>m0.8</b>	40	B9	5	15	32	32.47	18	11.91	10.47	
20			B1	4	12	16	17.92	24	11.5	8.48		
<b>DB1-4020</b> <b>DB1-2040</b>		<b>m1</b>	40	B9	6	18	40	40.59	22	14.45	12.59	
20			B1	5	15	20	22.4	30	14.49	10.6		

[Caution on Product Characteristics] ① The bore tolerance is -0.05 to -0.30, but it may be slightly higher at the center of the hole.

② For the dimensional accuracy of each part, see the dimensional tolerance of molded items in the table at right.

[Caution on Secondary Operations] ① As it is a molded item, bubbles may form inside the material. Avoid performing secondary operations.

Hub width	Hole length	Face width	Holding surface dia.	Allowable torque (N·m)	Allowable torque (kgf·m)	Backlash (mm)	Weight (g)	Catalog Number
H	I	J	K	Bending strength	Bending strength			
4	7	2.5	14.41	0.24	0.025	0~0.30	2.00	<b>DB0.5-4020</b>
4	—		—	0.092	0.0094		0.54	<b>DB0.5-2040</b>
6	10	3.5	24.17	0.91	0.093	0~0.48	6.26	<b>DB0.8-4020</b>
5	—		—	0.34	0.035		1.87	<b>DB0.8-2040</b>
7.5	12.5	4.5	30.44	1.59	0.16	0~0.60	11.9	<b>DB1-4020</b>
7	—		—	0.60	0.061		3.54	<b>DB1-2040</b>

■ Dimensional tolerance of molded item (unit: mm)

Dimensional classification	Grade	Rough grade
	3 or less	
4 to 6		±0.25
7 to 10		±0.30
11 to 18		±0.35
19 to 30		±0.40
Over 30		±0.50



When using the injection molded bevel gear as an idler gear and a shaft diameter smaller than the inside diameter of the molded gear, please press fit one of the following standard bushings.

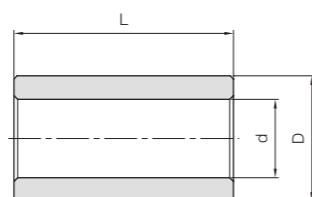

T8

Catalog Number	Inner dia.	Outside dia.	Length	Gear example
	$d_{+0.02/0}$	$D_{+0.02/-0.01}$	$L_{-0.3/0}$	
<b>BB30507</b>	3	5	7	DB0.8
<b>BB40612</b>	4	6	12	DB1

Material: Oil-free copper alloy





### ■ Catalog number

Note that the catalog numbers for KSP ground spiral bevel gears have a different configuration compared to other miters and bevel gears.

**KSP 031 001 G U L**

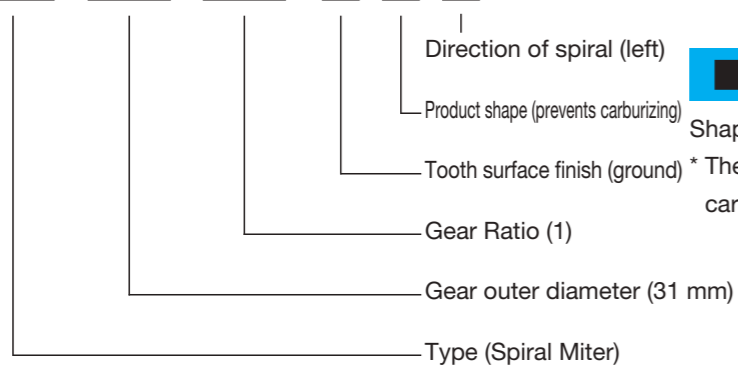

### ■ Features of KSP spiral bevel gears

1. High-strength, high-precision product of JIS grade 0.
2. Superior performance with regard to high speed, low noise, and low vibration.
3. Module is 1.5 to 6
4. Gear ratio types are 1, 1.5 and 2

### ■ Shape

Shape for secondary operations (with margin)  
\* The parts ---- in the figure below are protected from carburizing.

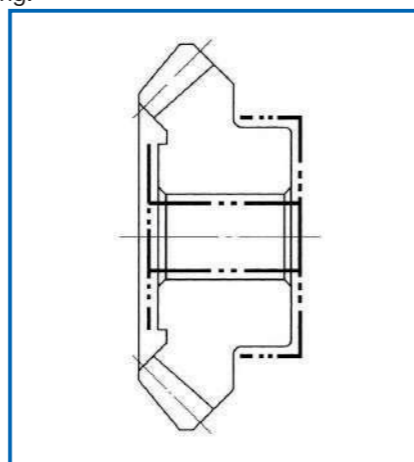

### ■ Transmission capacity table

1. The values in the transmission capacity table below are where the service factor is 1. Be sure to correct the load torque according to the table on the right. The corrected load torque is calculated by multiplying the load torque applied to the output shaft by service factor (Sf).
2. When using at increased speed (where gear is drive and pinion is driven), the torque of the pinion is the value obtained by multiplying the value shown in the transmission capacity table by the speed ratio.

NOTE 1: When the speed ratio is 1/1.5, the pinion torque is 1/1.5 of the value shown in the transmission capacity table.

### ■ Service factor (Sf)

Impact from motor	Impact from load		
	Uniform load	Moderate impact	Severe impact
Uniform load (electric motor, turbine, hydraulic motor, etc.)	1.0	1.25	1.75
Mild impact (multi-cylinder engine)	1.25	1.5	2.0
Moderate impact (single-cylinder engine)	1.5	1.75	2.25

### ■ Transmission capacity table (speed ratio 1/1)

Upper transmission capacity (kw) Lower output torque (N·m)

Figure number	Rotational speed (rpm)							
	50	100	300	600	900	1200	1800	3000
KSP031001	0.035	0.068	0.195	0.375	0.548	0.716	1.04	1.65
	6.65	6.51	6.20	5.98	5.82	5.69	5.51	5.25
KSP040001	0.092	0.179	0.511	0.980	1.43	1.86	2.69	4.25
	17.6	17.2	16.3	15.6	15.2	14.8	14.3	13.5
KSP053001	0.211	0.412	1.17	2.23	3.25	4.22	6.08	9.55
	40.4	39.3	37.3	35.6	34.5	33.6	32.3	30.4
KSP066001	0.367	0.715	2.02	3.85	5.59	7.26	10.4	16.3
	70.2	68.3	64.4	61.4	59.3	57.8	55.4	52.0
KSP078001	0.577	1.12	3.16	6.00	8.68	11.2	16.1	25.1
	109.8	106.9	101.0	95.5	92.2	89.5	85.5	79.8
KSP092001	0.901	1.75	4.91	9.31	13.5	17.4	24.9	38.6
	172.6	166.7	156.9	148.1	143.2	138.3	132.4	122.6
KSP105001	1.44	2.78	7.80	14.7	21.2	27.4	39.1	60.3
	274.6	265.8	248.1	234.4	225.6	218.7	207.9	192.2
KSP132001	2.33	4.50	12.6	23.6	34.0	43.7	62.0	95.0
	445.2	430.5	400.1	376.6	360.9	348.1	329.5	302.0
KSP157001	3.68	7.10	19.7	37.0	53.0	68.1	96.2	146
	704.1	678.6	628.6	589.4	562.9	542.3	510.9	466.8
KSP184001	5.31	10.2	28.3	52.8	75.5	96.8	136	206
	1010	976.7	901.2	841.4	801.2	770.8	722.8	656.1

### ■ Transmission capacity table (speed ratio 1/1.5)

Upper transmission capacity (kw) Lower output torque (N·m)

Figure number	Rotational Speed of Pinion (rpm)							
	50	100	300	600	900	1200	1800	3000
KSP0481.5	0.077	0.151	0.432	0.830	1.21	1.58	2.29	3.64
	22.2	21.6	20.6	19.8	19.3	18.9	18.2	17.4
KSP0611.5	0.159	0.309	0.882	1.69	2.46	3.21	4.64	7.33
	45.4	44.3	42.2	40.4	39.2	38.3	37.0	35.0
KSP0741.5	0.277	0.540	1.53	2.93	4.27	5.55	8.00	12.6
	79.4	77.4	73.4	70.1	68.0	66.3	63.7	60.1
KSP0901.5	0.466	0.908	2.57	4.90	7.12	9.24	13.3	20.8
	133.4	130.4	122.6	116.7	113.8	110.8	105.9	99.0
KSP1051.5	0.700	1.36	3.84	7.31	10.6	13.7	19.7	30.7
	201.0	195.2	183.4	174.6	168.7	163.8	156.9	147.1
KSP1241.5	1.03	2.00	5.63	10.7	15.5	20.0	28.6	44.5
	295.2	286.4	268.7	255.0	246.1	239.3	227.5	212.8
KSP1411.5	1.56	3.03	8.51	16.1	23.2	30.1	42.9	66.4
	448.2	434.4	406.0	384.4	370.7	358.9	341.3	317.7
KSP1631.5	2.27	4.39	12.3	23.2	33.4	43.1	61.4	94.6
	650.2	628.6	587.4	554.1	532.5	514.8	489.4	452.1
KSP1811.5	2.92	5.64	15.8	29.7	42.7	55.1	78.3	120
	836.5	809.0	754.1	710.0	680.6	658.0	623.7	574.7

### ■ Transmission capacity table (speed ratio 1/2)

Upper transmission capacity (kw) Lower output torque (N·m)

Figure number	Rotational Speed of Pinion (rpm)							
	50	100	300	600	900	1200	1800	3000
KSP039002	0.025	0.049	0.142	0.275	0.404	0.528	0.770	1.23
	9.63	9.45	9.07	8.76	8.57	8.41	8.17	7.83
KSP056002	0.075	0.147	0.423	0.814	1.19	1.55	2.26	3.59
	28.8	28.1	27.0	26.0	25.3	24.8	23.9	22.8
KSP075002	0.185	0.361	1.03	1.98	2.89	3.76	5.45	8.61
	70.7	69.0	65.7	63.1	61.3	59.9	57.9	54.8
KSP096002	0.364	0.710	2.02	3.86	5.62	7.31	10.5	16.6
	139.3	135.3	128.5	122.6	119.6	116.7	111.8	105.9
KSP119002	0.649	1.26	3.58	6.82	9.90	12.9	18.5	29.0
	248.1	241.2	227.5	217.7	209.9	205.0	196.1	184.4
KSP145002	1.07	2.08	5.87	11.2	16.2	21.0	30.1	46.9
	408.9	397.2	373.6	356.0	343.2	333.4	319.7	298.1
KSP172002	1.78	3.45	9.72	18.4	26.6	34.5	49.3	76.5
	680.6	660.0	618.8	587.4	565.8	549.2	523.7	487.4



# Ground Spiral Bevel Gears



Specifications	
Precision grade	JIS B 1704: 1978 grade 0
Gear teeth	Gleason
Pressure angle	20°
Helix angle	35°
Material	SCM415*
Heat treatment	Carburized (Bore and hub are carburized)
Tooth hardness	60 to 63HRC**

\* The material of module 3.5 and above is SCM420.  
\*\* Modules 1.5 and 2 have the tooth hardness of 80 to 83 HRA.

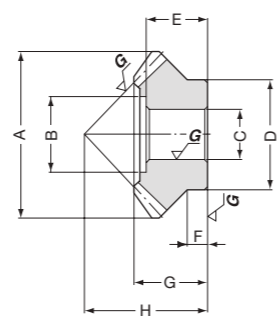

A

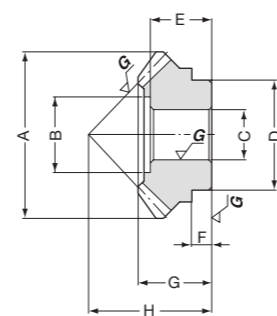

A'

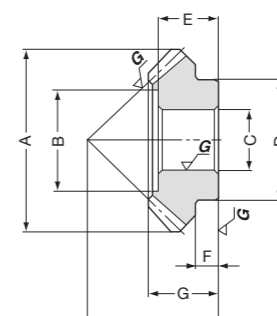

B

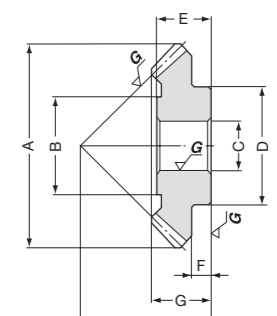

C

Catalog Number	Gear Ratio	Module	No. of teeth	Direction of spiral	Pitch dia.	Face width	Shape	Outside dia.	Holder surface dia.	Bore	Hub dia.	Hole length
								A	B	CH7	D	E
KSP031001GU L KSP031001GU R	1	m1.5	20	L R	30	7	A	30.5	16.5	10	22	13
KSP040001GU L KSP040001GU R		m2	20	L R	40	9	B	40	22.5	12	31	14
KSP078001GU L KSP078001GU R		m3.5	22	L R	77	18	B	78	43	20	54	27
KSP105001GU L KSP105001GU R		m4.5	23	L R	103.5	25	C	105	50	26	70	35
KSP132001GU L KSP132001GU R		m5	26	L R	130	29	C	132	64	30	82	41
KSP157001GU L KSP157001GU R		m5.5	28	L R	154	34	C	157	76	32	92	47
KSP184001GU L KSP184001GU R		m6	30	L R	180	38	C	184	84	40	101	51
KSP0481.5GU P KSP0481.5GU G		1.5	m2	16 24	L R	32 48	9	A' B	34 48	17.5 30	10 12	24 30
KSP0741.5GU P KSP0741.5GU G	m2.75		18 27	L R	49.5 74.25	15	A' B	52 74	27 44.5	14 20	40 50	20 25
KSP075002GU P KSP075002GU G	2	m2.5	15 30	L R	37.5 75	14	A' C	40 75	20 36	12 16	30 44	17 24
KSP096002GU P KSP096002GU G			m3	16 32	L R	48 96	18	B C	53 96	23.5 46	12 20	36 56
KSP119002GU P KSP119002GU G		m3.5		17 34	L R	59.5 119	22	A C	65 119	34 54	16 26	44 63

Hub width	Total length	Mounting distance	Machinable MAX bore	Allowable torque (kgf-m)	Backlash (mm)	Weight (kg)	Catalog Number
F	G	H					
6	15	25	12	0.61	0 ~0.05	0.04	KSP031001GU L KSP031001GU R
7	16.5	30	16	1.59	0 ~0.05	0.09	KSP040001GU L KSP040001GU R
12	32	57	32	9.74	0.05~0.10	0.59	KSP078001GU L KSP078001GU R
14	39	72	40	23.9	0.05~0.10	1.33	KSP105001GU L KSP105001GU R
14	45	88	48	38.4	0.05~0.10	2.49	KSP132001GU L KSP132001GU R
20	53.5	105	55	60.1	0.05~0.10	3.90	KSP157001GU L KSP157001GU R
17	56.5	118	62	85.8	0.05~0.10	5.79	KSP184001GU L KSP184001GU R
4.5 7	14.5 19	31 30	— 20	2.02	0 ~0.05	0.05 0.14	KSP0481.5GU P KSP0481.5GU G
6 12	22 29	46 45	20 35	7.15	0.05~0.10	0.20 0.49	KSP0741.5GU P KSP0741.5GU G
4.5 11	19.5 25.5	44 38	14 25	6.43	0.05~0.10	0.10 0.44	KSP075002GU P KSP075002GU G
2.5 12	21.5 31	53 47	19 32	12.5	0.05~0.10	0.20 0.91	KSP096002GU P KSP096002GU G
3.6 15	27.5 35.5	67 55	25 40	22.2	0.05~0.10	0.36 1.45	KSP119002GU P KSP119002GU G

[Caution on Product Characteristics] ① The allowable torque is the value at RPM 600. For other data, see the Transmission Capacity Table.





## Adjustment of tooth contact

### <Center of tooth contact>

- (1) Near the center of the tooth length for the length direction
- (2) Ideally, the tooth width direction should be at the center of the width or slightly closer to the toe.

When adjusting the backlash and mounting the gear in the case, adjust the case in order to achieve the tooth contact as shown in the figure below.

Deviation of the tooth contact from the normal position may adversely affect the strength and quietness.

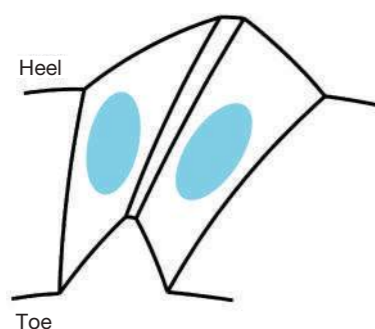

### (1) Tooth contact in case of a shaft-angle error

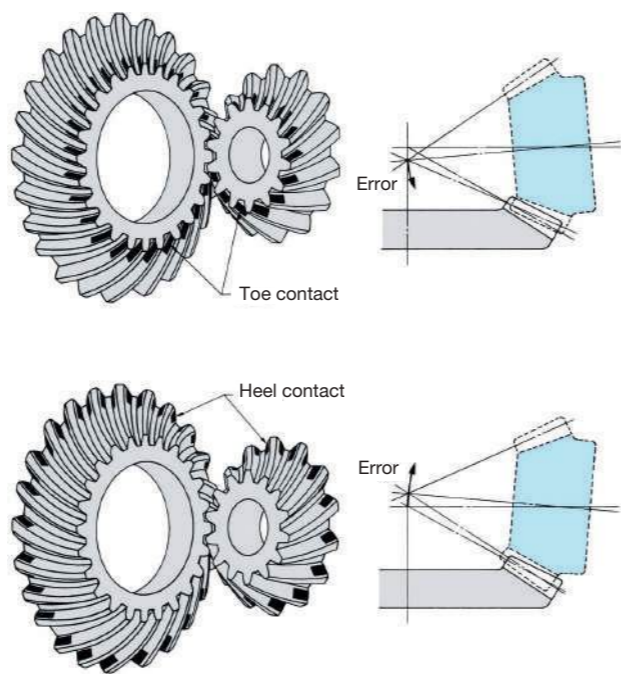

### (2) Tooth contact in case of a shaft-offset error

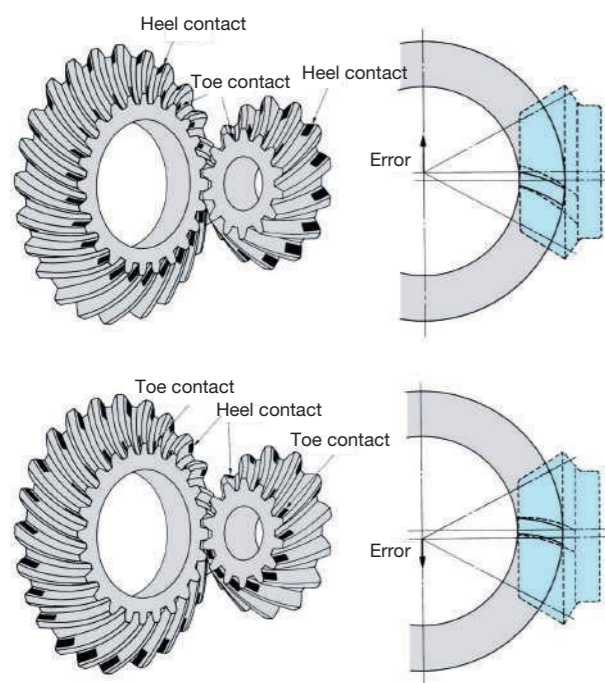

### (3) Tooth contact in case of a pinion set position error

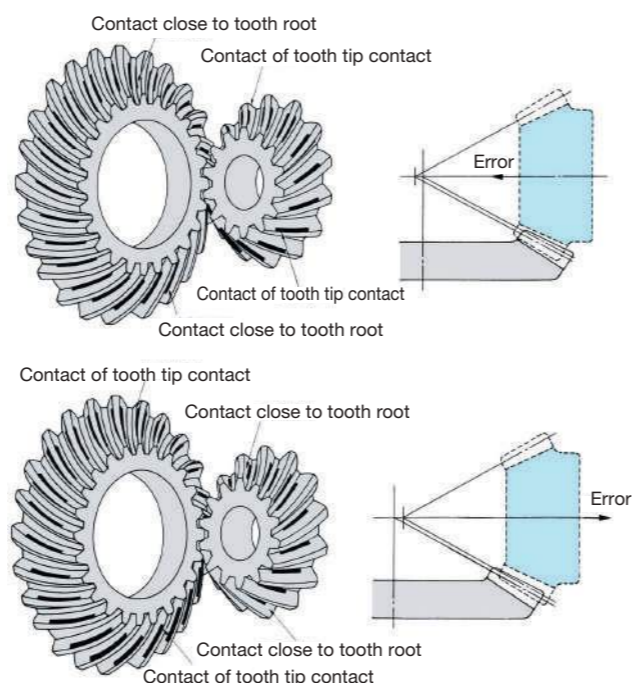

# Screw Gears

SN-H Hardened Screw Gears	SN Screw Gears	SUN Stainless Steel Screw Gears	AN Screw Gears	PN Plastic Screw Gears
Material: S45C m1-4 Page 384	Material: S45C m1-4 Page 384	Material: SUS303 m1-2.5 Page 388	Material: CAC702 (A&BC2) m1-3 Page 390	Material: MC901 m1-3 Page 392

**M** Includes Made to Order

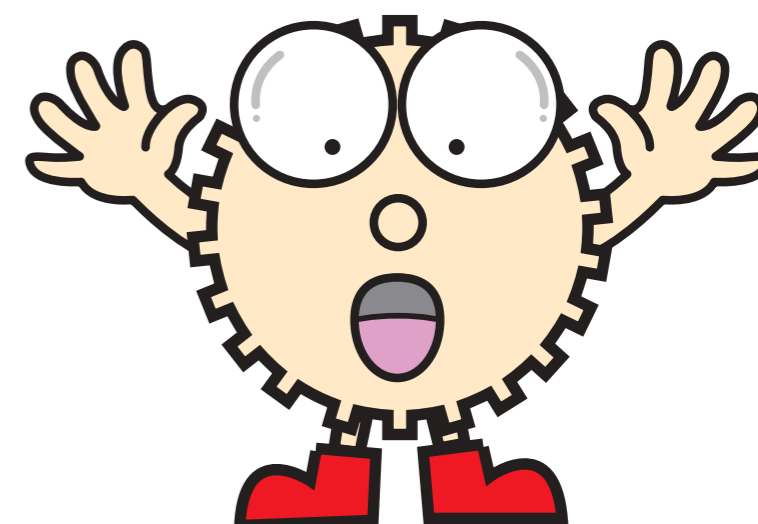

## Catalog Number of KHK Stock Gears

The Catalog Number for KHK stock gears is based on the simple formula listed below. Please order KHK gears by specifying the Catalog Numbers.

(Example) Screw Gears

